

MEETING: **REGULAR MEETING OF THE HISTORIC PRESERVATION COMMISSION**

DATE & TIME: **Wednesday, June 25, 2025 at 6:00 PM**

LOCATION: **Germantown Village Hall Conference Room A
N112 W17001 Mequon Road**

NOTICE: Citizens not wishing to attend the meeting personally or virtually may submit any public comments by sending an email to comments@germantownwi.gov by 4 p.m. on the day of the meeting so that it can be provided to the members of the body for their consideration.

AGENDA

- I. **CALL TO ORDER:** *This meeting has been given public notice in accordance with Section 19.83 and 19.84, Wis. Stats, in such form that will apprise the general public and news media of subject matter that is intended for consideration and action.*
- II. **ROLL CALL:**
- III. **CITIZEN INPUT:** *(Please be advised per 19.84(2) that information and comment will be received from the public. It is the policy of this municipality that public input be limited to a four (4) minute period per person with a time extension granted at the discretion of the Chairperson. Be advised that there may be limited discussion of the information received but no action will be taken under public comments.) Comments that may be injurious to village personnel or other individuals will not be allowed.*
- IV. **APPROVAL OF MINUTES:**
 - A. May 5, 2025 (ACTION)
- V. **UNFINISHED BUSINESS:**
 - A. Application for Certification of Appropriateness - Granary Structure at 13369 Fond du Lac Ave (ACTION)
 - B. Historic Picture Restoration - Update (DISCUSSION)
 - C. Other Historic Properties (DISCUSSION)
- VI. **NEW BUSINESS:**
 - A. Application for Certification of Appropriateness - South and North Porch Replacements at W156N11685 Pilgrim Rd (ACTION)
- VII. **ADJOURNMENT:**

UPON REASONABLE NOTICE, efforts will be made to accommodate the needs of disabled individuals through appropriate aids and services. For additional information or to request this service, please contact the Village Clerk at (262)250-4745 at least 2 days prior to the meeting.

Notice is hereby given that a possible quorum of other boards, committees, and/or commissions may attend this meeting to gather information about an item over which they have decision-making responsibility. This may constitute a meeting of these bodies per State ex rel. Badke v Greendale Village Board, even though these bodies will not take formal action at this meeting.

MEETING:	REGULAR MEETING OF THE HISTORIC PRESERVATION COMMISSION
DATE AND TIME:	Monday, May 5, 2025 5:00 PM
LOCATION:	Germantown Village Hall Board Room N112 W17001 Mequon Road

MINUTES

- I. **CALL TO ORDER:** *This meeting has been given public notice in accordance with Section 19.83 and 19.84, Wis. Stats, in such form that will apprise the general public and news media of subject matter that is intended for consideration and action.*

Chairperson Trustee Rick Miller called the Historic Preservation Commission meeting to order.

II. **ROLL CALL:**

Present: Trustee Rick Miller, Member Barbara Mendenhall, Member Chris Kauth, Member Mark Kauth

Absent: Member Katelyn LeTourneau

- III. **CITIZEN INPUT:** *(Please be advised per 19.84(2) that information and comment will be received from the public. It is the policy of this municipality that public input be limited to a three (3) minute period per person with a time extension granted at the discretion of the Chairperson. Be advised that there may be limited discussion of the information received but no action will be taken under public comments.)*

IV. **CONSENT AGENDA:**

- A. Minutes: February 17, 2025 (Action)

Motion: Approve as presented

Motioned By: Member Mendenhall

Seconded By: Member Mark Kauth

Yes: Trustee Rick Miller, Member Mendenhall, Member Chris Kauth, Member Mark Kauth

No: None

Abstain: None

Motion Carried (Yes 4, No 0, Abstained 0)

V. **UNFINISHED BUSINESS:**

A. Historic Picture Restoration - Update (Discussion)

We are getting a small frame to house the narrative on the picture. Mark and Chris Kauth will shop for the proper frame.

B. Property Discussion W148N12696 Pleasant View Dr (Discussion)

Scott Sommer was unable to attend. Discussion postponed.

C. Discuss Other Historic Properties (Discussion)

Various properties were discussed. No action was taken.

VI. NEW BUSINESS:

A. Application for Certification of Appropriateness - Granary Structure at 13369 Fond du Lac Ave (Action)

Discussion regarding the reason for our approval on this property. Typically we have plans or drawings to show the structure so we can determine the appropriateness of it. This structure is not moved yet, nor is there a rendering. We want to invite Associate Planner Jordan Yanke to our next meeting to discuss.

Motion: Postpone

Motioned By: Member Mendenhall

Seconded By: Member Chris Kauth

Yes: Trustee Rick Miller, Member Mendenhall, Member Chris Kauth, Member Mark Kauth

No: None

Abstain: None

Motion Carried (Yes 4, No 0, Abstained 0)

VII. ADJOURNMENT:

Chairperson Trustee Rick Miller adjourned the Historic Preservation Commission meeting.



Germantown's Luther West Church built 1887

GERMANTOWN HISTORICAL SOCIETY

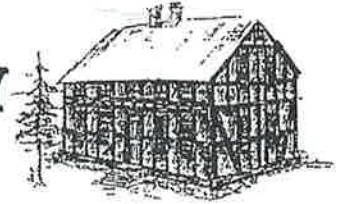

April 9, 2025

Village of Germantown
Historic Preservation Commission
N112 W17001 Mequon Road
P O Box 337
Germantown, WI 53022

Enclosed you will find an Application for Certification of Appropriateness for the granary log structure located at 13369 Fond du Lac Avenue, one mile north of Dheinsville. The log building has been offered to the Germantown Historical Society by the current owner of the property, Brian Kazmierczak.

We have met with the Parks Department and have received tentative approval for the placement of the structure at Dheinsville Historical Park. We now would like to meet with the Historic Preservation Commission and request your approval of this log granary move to Dheinsville Park.

Please review the enclosed paperwork and let us know your thoughts and when we might set up a meeting with your commission.

Thank you,

Jim Dix, President
Germantown Historical Society



POST OFFICE BOX 31, GERMANTOWN, WISCONSIN 53022



Village of

Germantown
Willkommen

**HISTORIC PRESERVATION
COMMISSION**
N112 W17001 Mequon Road
P.O. Box 337
Germantown, WI 53022-0337

APPLICATION FOR certification of appropriateness

PURSUANT TO SECTION 17.00 OF THE MUNICIPAL CODE

PLEASE READ AND COMPLETE THIS APPLICATION CAREFULLY. ALL APPLICATIONS MUST BE SIGNED AND DATED.

1. APPLICANT OR AGENT

Germantown Historical Society Inc
P O Box 31
Germantown, WI 53022
Email: ghsjdix@gmail.com
PHONE [REDACTED]

2. PROPERTY OWNER

Village of Germantown

PHONE

3. PROPERTY ADDRESS

Dheinsville Historical Park
N128 N18780 Holy Hill Road

4. TAX KEY NUMBER

-

5. historic designation

<u>HISTORIC NAME OF PROPERTY</u>	<u>DATE OF HISTORIC DESIGNATION</u>
Caspar Granary	

CHECK HERE IF THIS PROPERTY IS THREATENED WITH DEMOLITION OR DESTRUCTION.

6. purpose of application

CHOOSE ONE OR MORE OF THE FOLLOWING

- ALTERATION OR ADDITION TO AN HISTORIC STRUCTURE OR SITE
- RECONSTRUCTION OR RESTORATION OF ALL OR PART OF AN HISTORIC STRUCTURE OR SITE
- DEMOLITION

7. description of proposed activity

BRIEFLY DESCRIBE. ATTACH PAGES AS NECESSARY

The Caspar homestead is currently located one mile north of Dheinsville Historical Park . Their family granary was likely constructed in the early 1840's and was built using hand-hewn logs for all the materials. The interior walls never were covered with any finished materials. We wish to expose all the logs for the public to experience.

8. attach plans and elevation for proposed alteration

BRIEFLY DESCRIBE THE REASON FOR YOUR REQUEST

We would like to relocate the log structure to the Dheinsville Historical Park and preserve an authentic 1840's homestead building for future generations to enjoy and learn about the life of these early Germantown pioneers.

We have met with the Germantown Park Department and they have tentatively approved moving the granary to the Historical Park.

I have enclosed a letter of recommendation from Alan Pape, Historic Preservation Planner.

I have also enclosed several pictures of the log granary for your review.

PLEASE NOTE: THE ISSUANCE OF THIS CERTIFICATE OF APPROPRIATENESS DOES NOT RELEASE THE APPLICANT/OWNER FROM OBTAINING THE REQUIRED PERMITS AND APPROVALS.

9. SIGNATURES

James Dix
APPLICANT

4/9/2025

DATE

OWNER

DATE

President G.H.S.



Jim Dix <ghsjdix@gmail.com>

Letter of Recommendation

Alan Pape <[REDACTED]>
To: Jim Dix <ghsjdix@gmail.com>

Thu, Mar 27, 2025 at 2:14 PM

To whom it may concern.

Last fall I visited and evaluated the historic Casper family log granary in Germantown. It is an amazing structure that uses recycled parts from original farm log buildings all in good solid condition. As an adaptive restoration and exhibit building at the Diensville Settlement it will become a special visitor attraction not found anywhere else.

Alan C. Pape
Historic preservation planner
Greenbush, WI
[REDACTED]

Sent from my iPhone

On Mar 27, 2025, at 6:57 AM, Jim Dix <ghsjdix@gmail.com> wrote:

[Quoted text hidden]

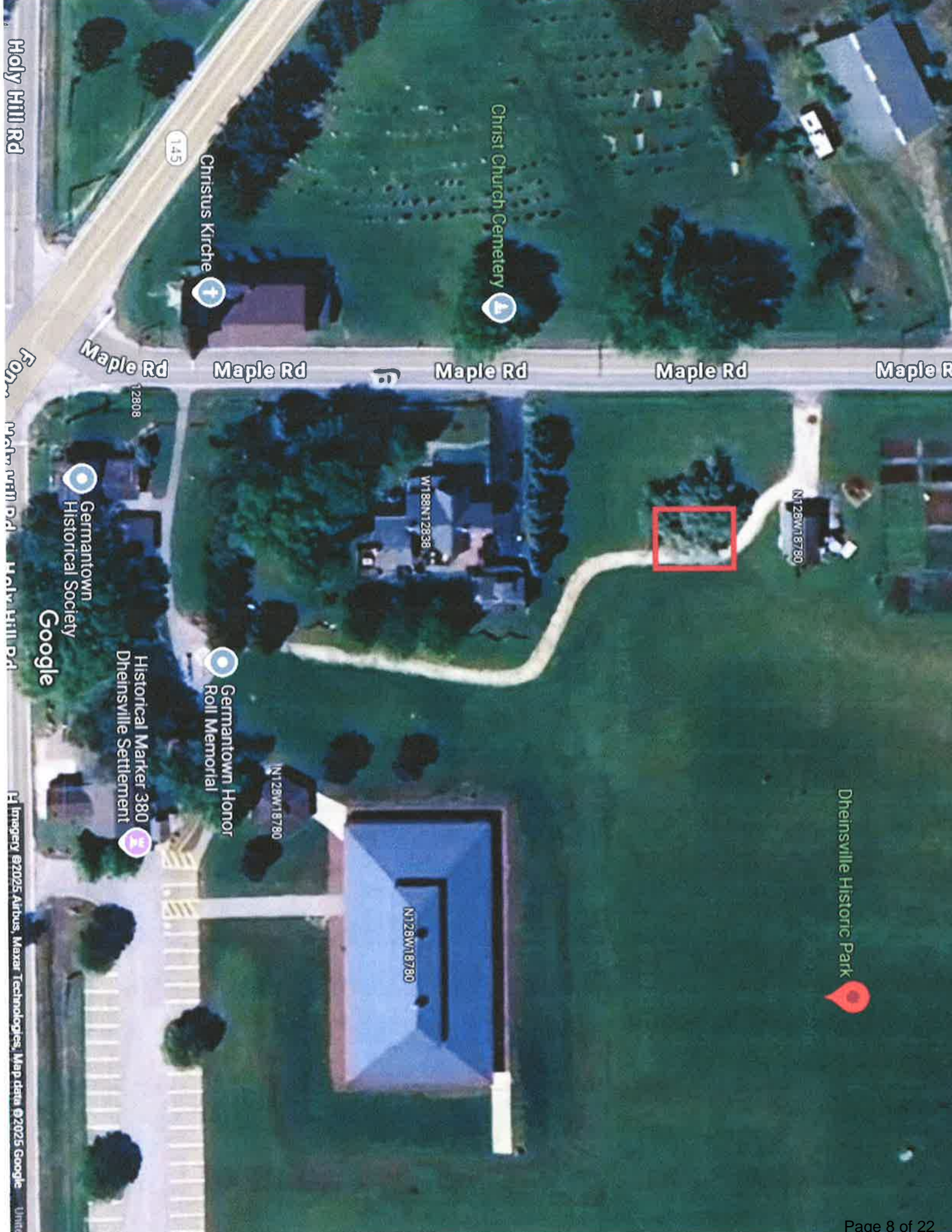

Holy Hill Rd

145

Christus Kirche

Christ Church Cemetery

Maple Rd

Maple Rd

Maple Rd

Maple Rd

Maple Rd

12808

Germantown Historical Society

Google

Historical Marker 380
Dheinsville Settlement

Germantown Honor
Roll Memorial

N128W18780

N128W18780

Dheinsville Historic Park

N128W18780

W188N12838

Imagery ©2025, Airbus, Maxar Technologies, Map data ©2025 Google

This brown siding
will be removed to
expose the
exterior
logs

This gray part
will not be
included







BUSINESS OF THE HISTORIC PRESERVATION COMMISSION

MEETING DATE: June 25, 2025

PLACEMENT: Discussion

ITEM TITLE: Historic Picture Restoration - Update (DISCUSSION)

SUBMITTED BY:

SUMMARY EXPLANATION:

ATTACHMENT:

STAFF RECOMMENDATION:

ACTION BY Committee:

BUSINESS OF THE HISTORIC PRESERVATION COMMISSION

MEETING DATE: June 25, 2025

PLACEMENT: Discussion

ITEM TITLE: Other Historic Properties (DISCUSSION)

SUBMITTED BY:

SUMMARY EXPLANATION:

ATTACHMENT:

STAFF RECOMMENDATION:

ACTION BY Committee:



APPLICATION FOR certification of appropriateness

Pursuant to Section 17.00 of the Municipal Code

Please read and complete this application carefully. All applications must be signed and dated.

1. APPLICANT OR AGENT	2. PROPERTY OWNER
Kipley Wagner	Kipley & Magdelene Wagner
Phone [REDACTED]	Phone [REDACTED]
3. PROPERTY ADDRESS	4. TAX KEY NUMBER
W156N11685 Pilgrim Rd	GTNV#221-081
5. historic designation	
Historic Name of Property	Date of historic designation
The Jacob Schlaefer Homestead	2014
<input type="checkbox"/> Check here if this property is threatened with demolition or destruction.	
6. purpose of application	
Choose one or more of the following	
<input type="checkbox"/> Alteration or addition to an historic structure or site	
<input checked="" type="checkbox"/> Reconstruction or restoration of all or part of an historic structure or site	
<input type="checkbox"/> demolition	
7. description of proposed activity	
Briefly describe. Attach pages as necessary	
1. Restore Front (South) Porch by replacing the deck and deteriorated roof beams. Also replace adjacent concrete patio.	
2. Replace rear (North) Porch by replacing the deck and screened wall.	



8. attach plans and elevation for proposed alteration

Briefly describe the reason for your request

Restore due to deteriorating conditions.

Please note: the issuance of this certificate of appropriateness does not release the applicant/owner from obtaining the required permits and approvals.

9. SIGNATURES



Applicant

5/21/25
Date



Owner

5/21/2025
Date





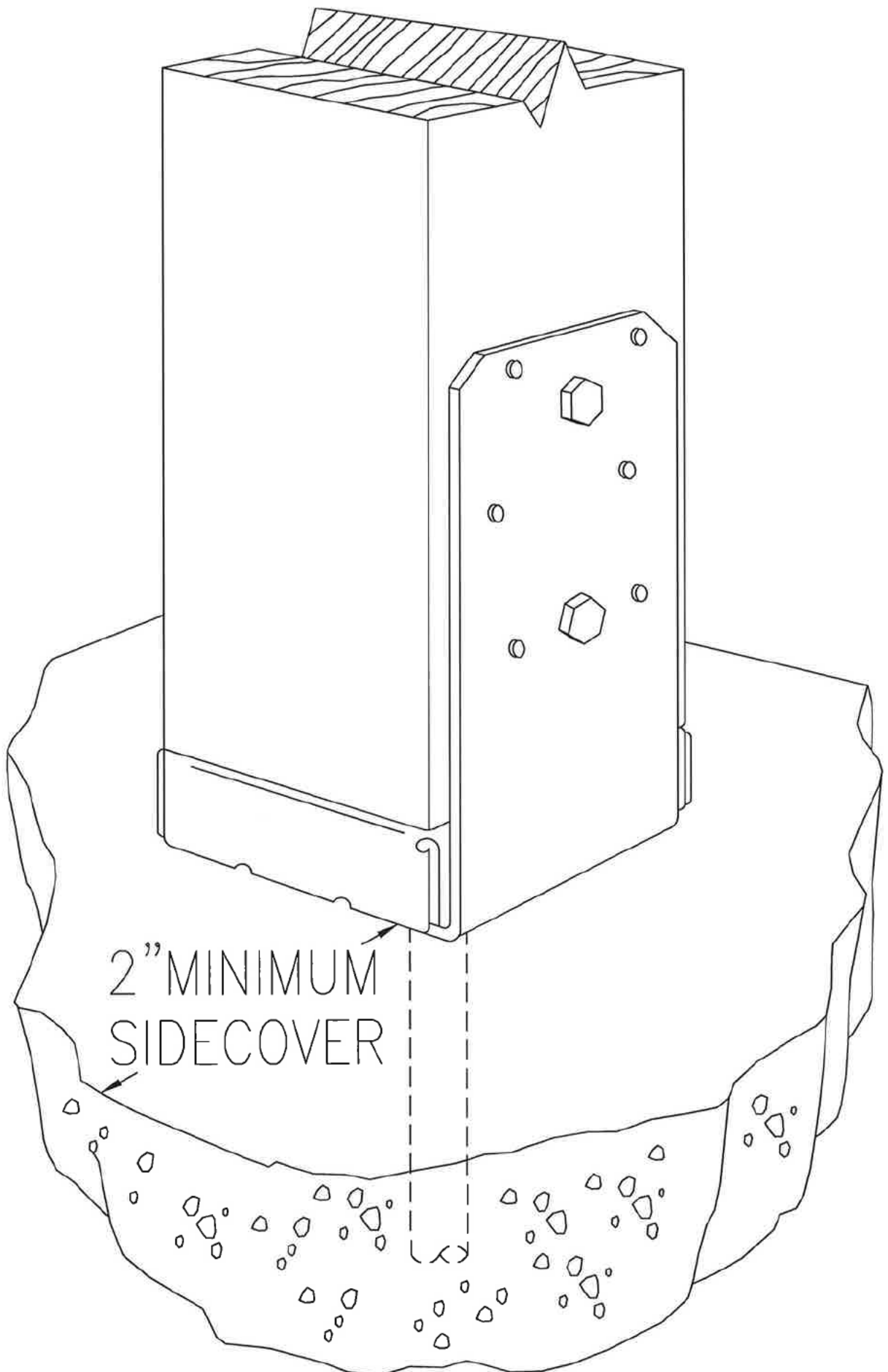

2" MINIMUM
SIDECOVER

Simpson Strong-Tie
ABU44

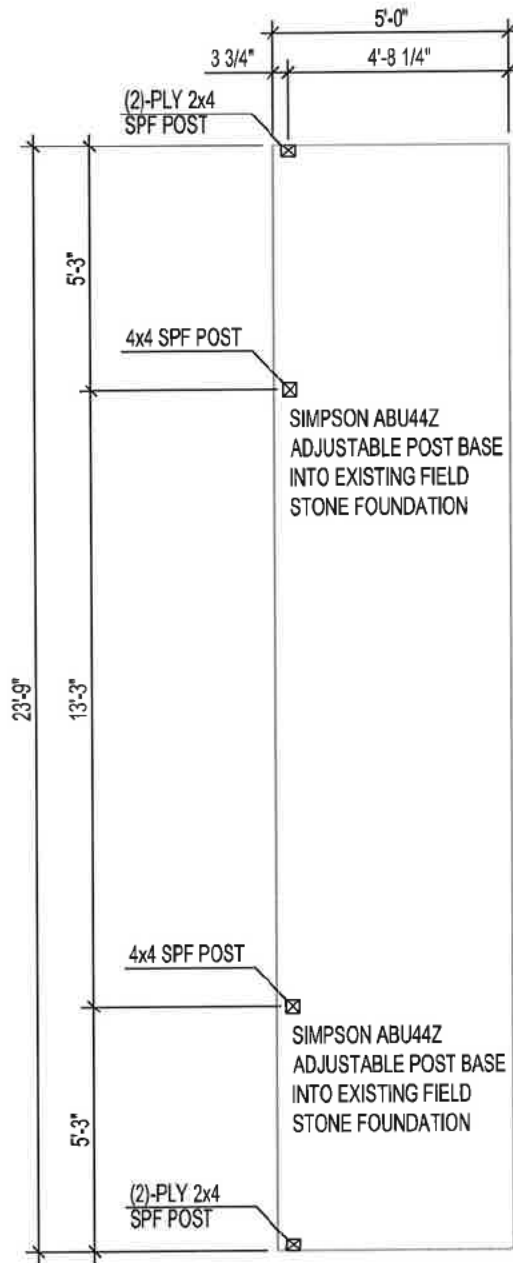

1 BACK PORCH FOUNDATION PLAN
S1 SCALE: 1/4" = 1'-0"

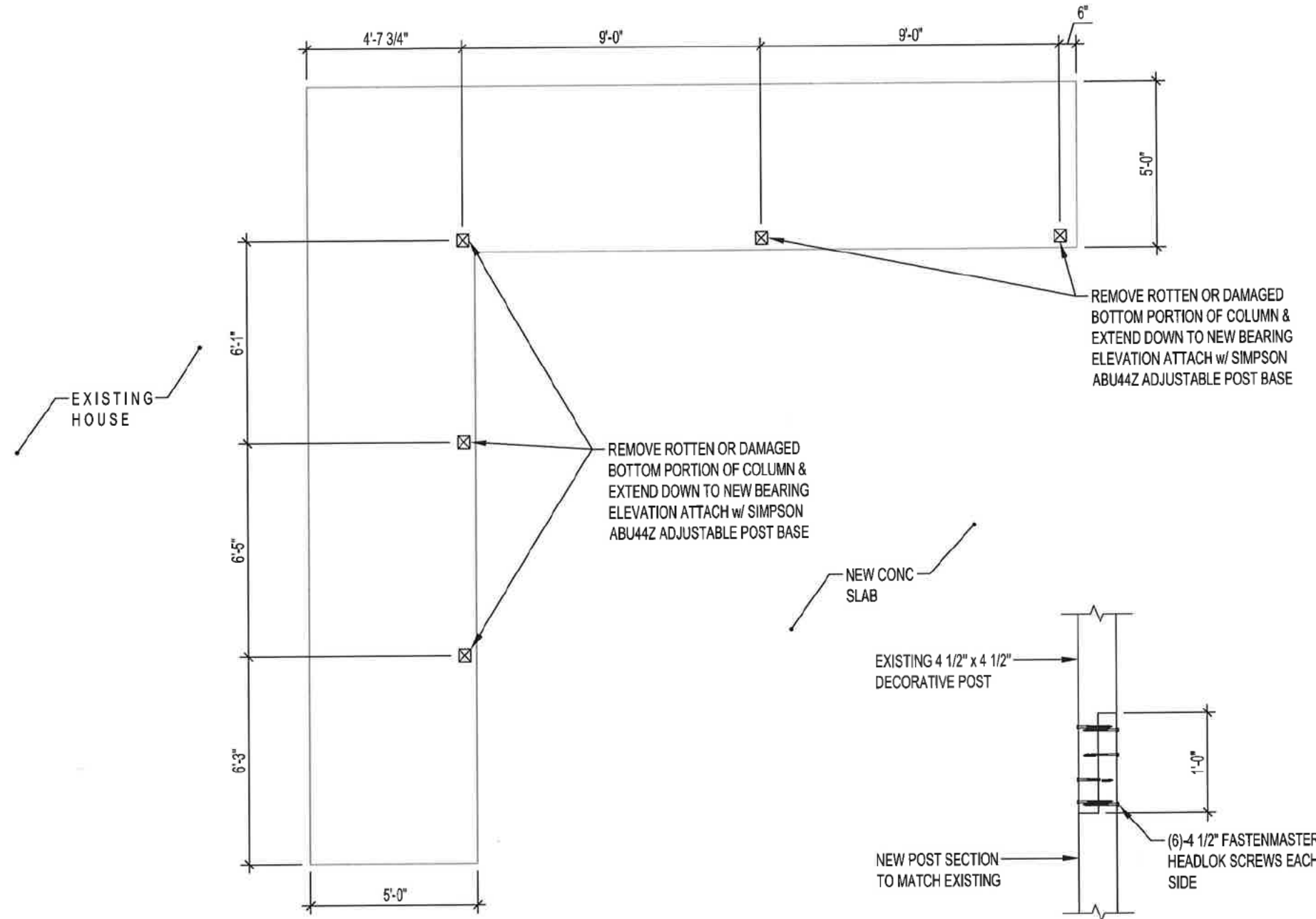

2 FRONT PORCH FOUNDATION
S1 SCALE: 1/4" = 1'-0"

3 SECTION
S1



JPL CONSTRUCTION, LLC.
 GENERAL CONTRACTOR
 (262) 894-6025

WAGNER PORCH

FOUNDATION PLAN

SCALE: AS NOTED
 DRAWN BY: ED
 CHECKED BY: JL
 DATE: 05/13/2025

S1

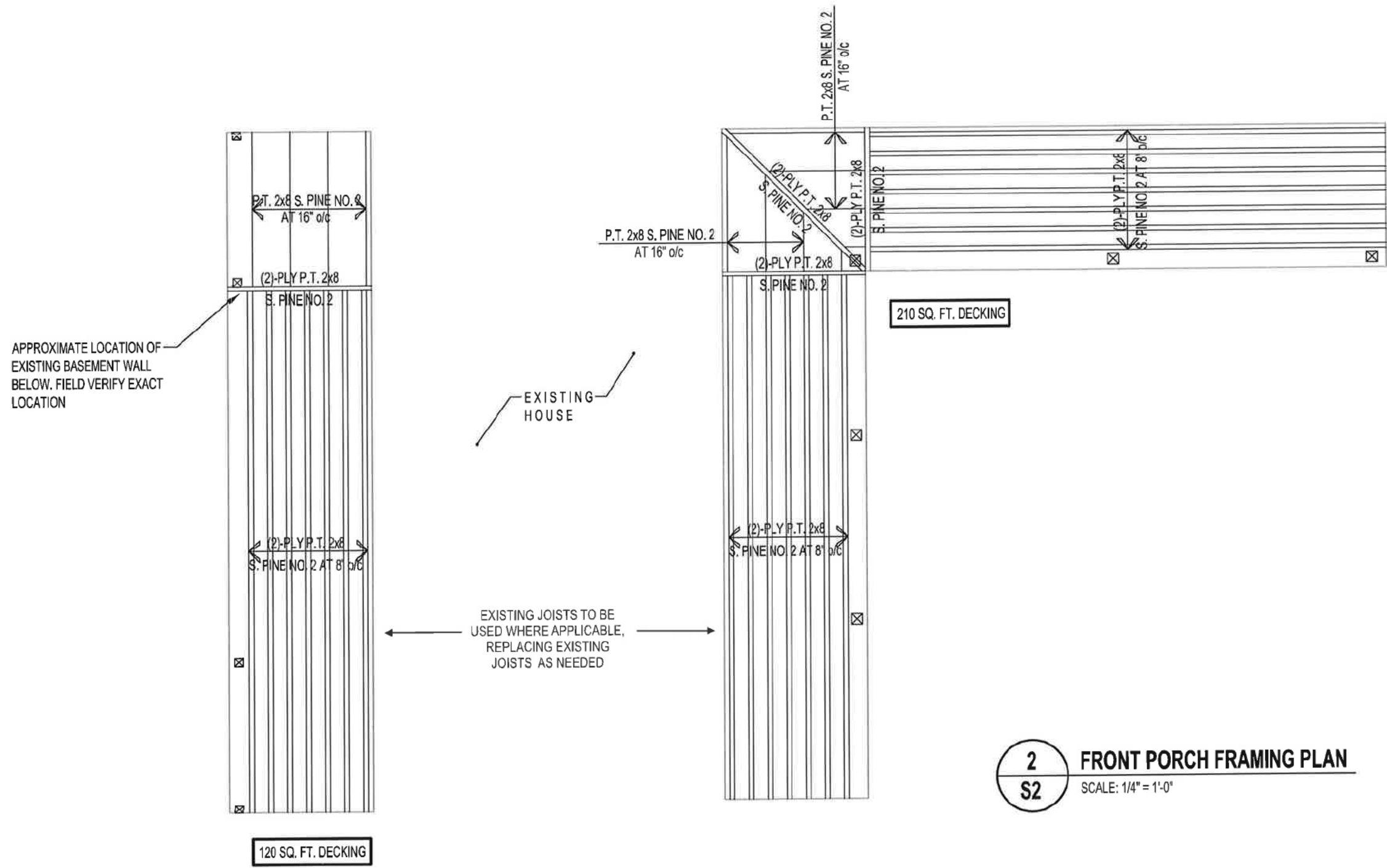

1
S2 **BACK PORCH FRAMING PLAN**
SCALE: 1/4" = 1'-0"

2
S2 **FRONT PORCH FRAMING PLAN**
SCALE: 1/4" = 1'-0"



JPL CONSTRUCTION, LLC.
GENERAL CONTRACTOR
(262) 894-6025

WAGNER PORCH

DECK FRAMING PLAN

SCALE: AS NOTED
DRAWN BY: ED
CHECKED BY: JL
DATE: 05/13/2025

S2

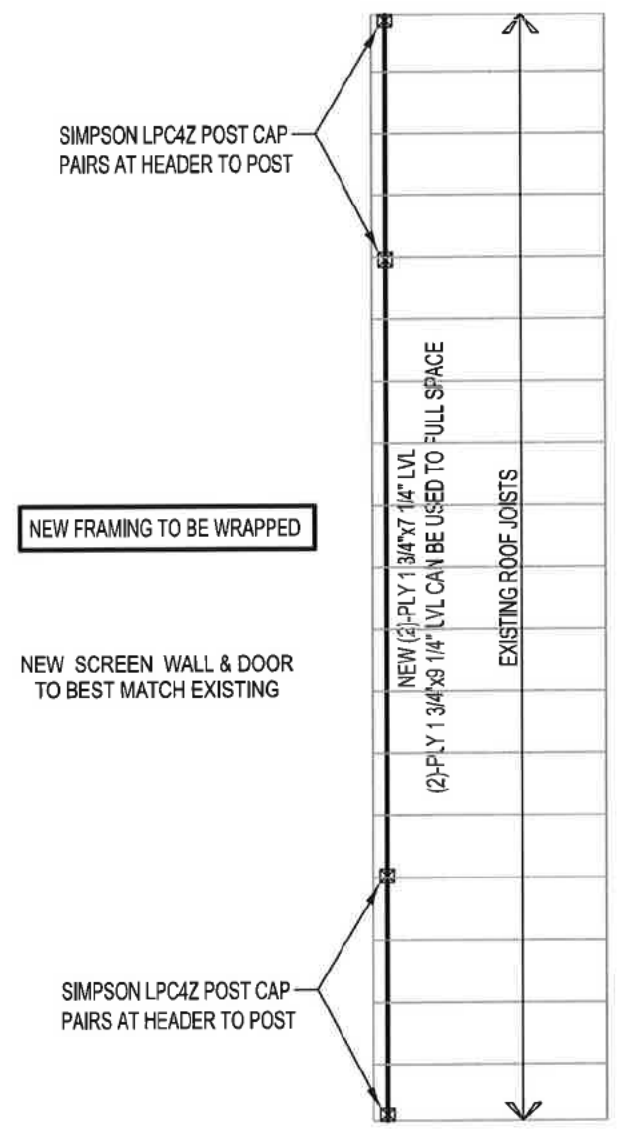

1
S3 **BACK PORCH FRAMING PLAN**
SCALE: 1/4" = 1'-0"

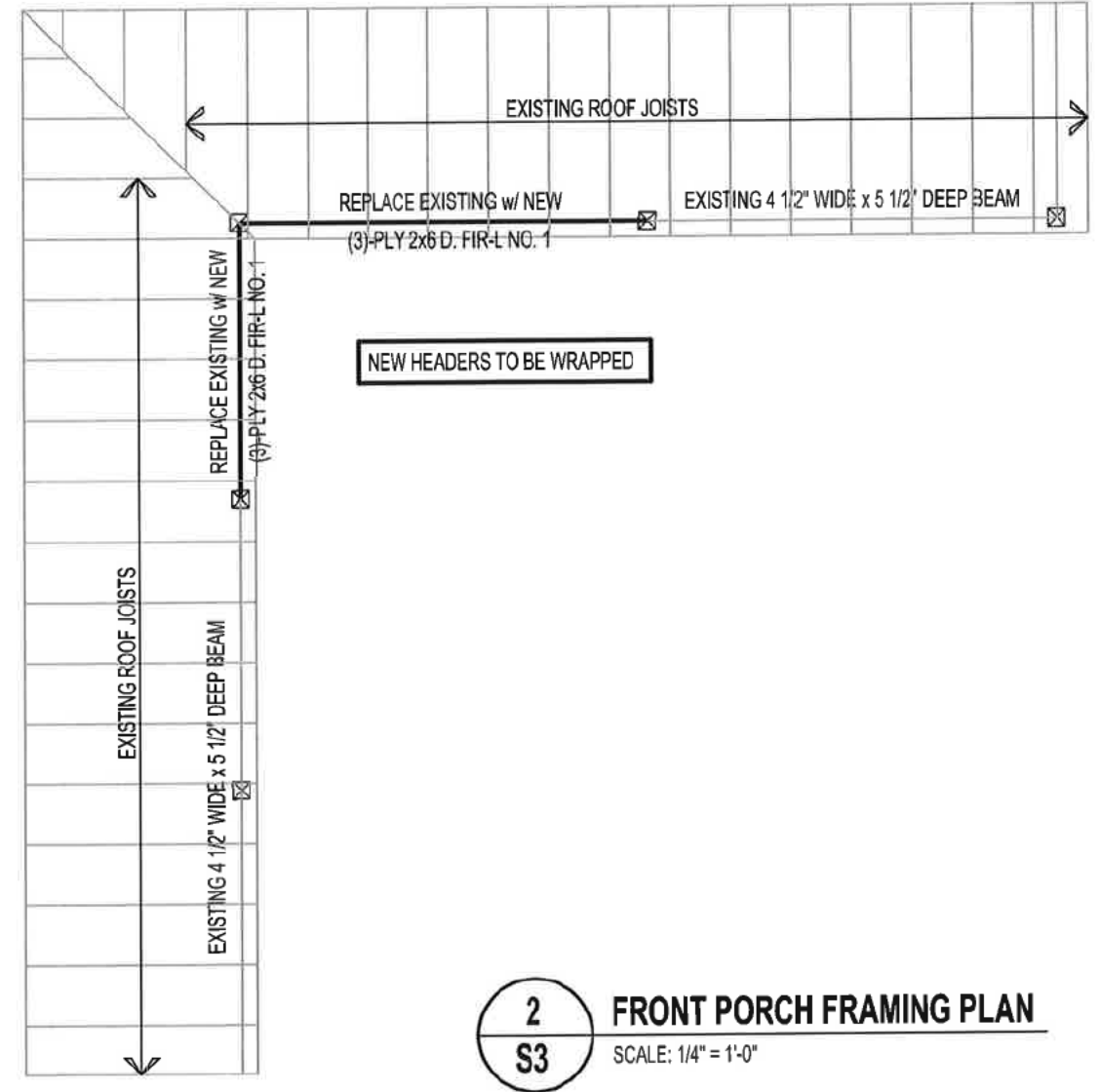

2
S3 **FRONT PORCH FRAMING PLAN**
SCALE: 1/4" = 1'-0"



JPL CONSTRUCTION, LLC.
GENERAL CONTRACTOR
(262) 894-6025

WAGNER PORCH

FRAMING PLAN

SCALE: AS NOTED
DRAWN BY: ED
CHECKED BY: JL
DATE: 05/13/2025

S3

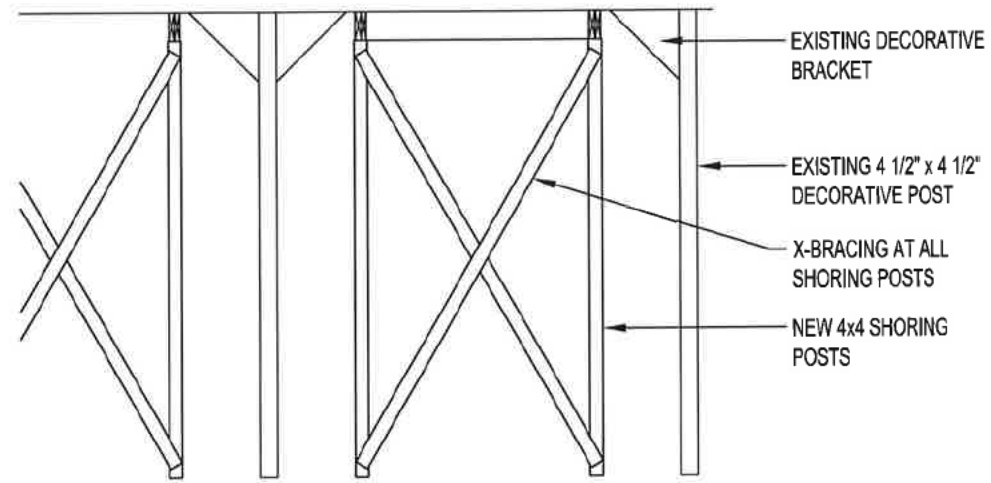

2
S4 **FRONT PORCH SHORING ELEVATION**
SCALE: 1/4" = 1'-0"

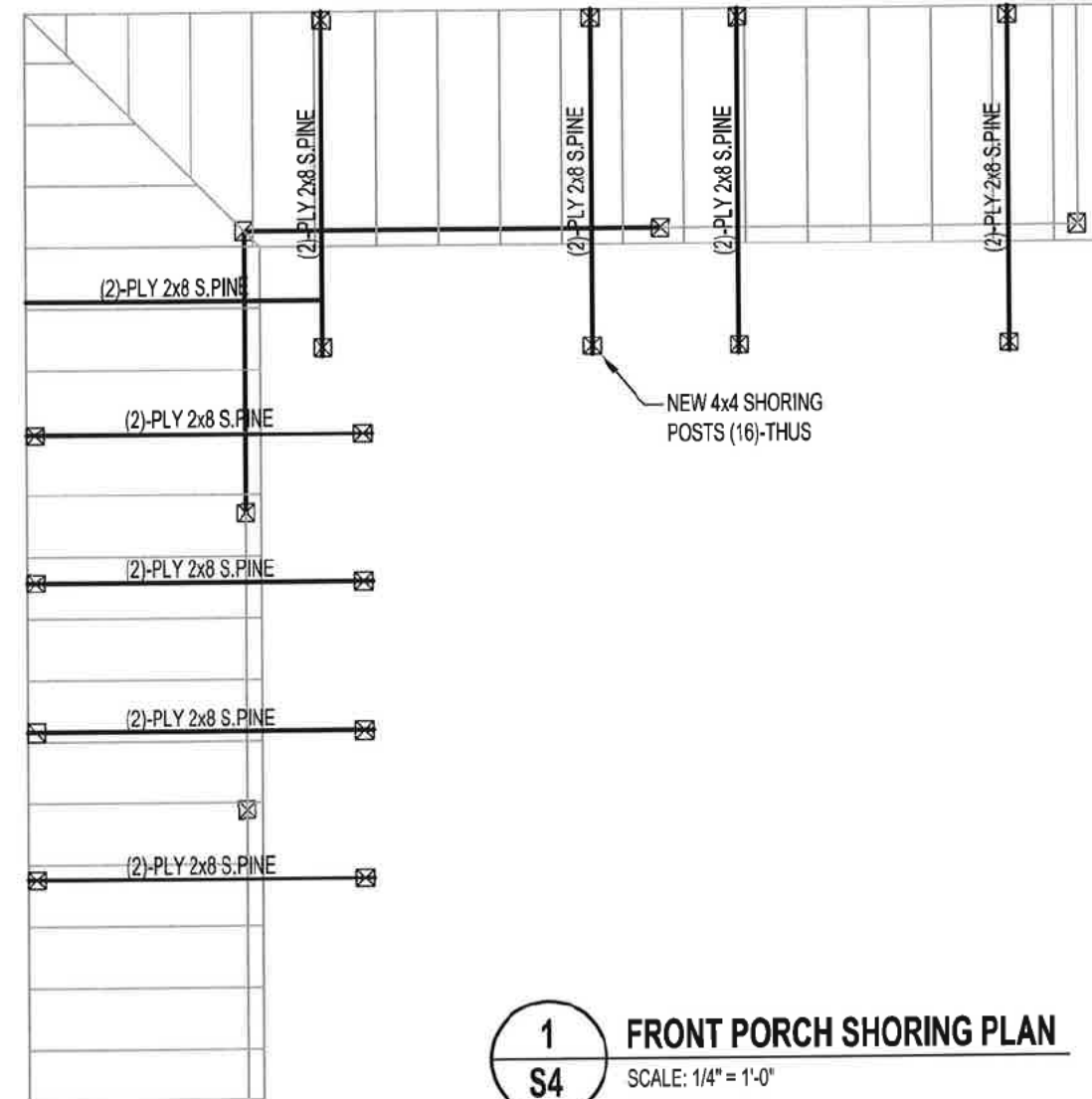

1
S4 **FRONT PORCH SHORING PLAN**
SCALE: 1/4" = 1'-0"



JPL CONSTRUCTION, LLC.
GENERAL CONTRACTOR
(262) 894-6025

WAGNER PORCH

SHORING PLAN

SCALE: AS NOTED
DRAWN BY: ED
CHECKED BY: JL
DATE: 05/13/2025

S4