

MEETING: REGULAR MEETING OF THE PARK & RECREATION COMMISSION

DATE & TIME: Wednesday, July 16, 2025 at 5:30 PM

**LOCATION: Germantown Village Hall Board Room
N112 W17001 Mequon Road**

NOTICE: Citizens not wishing to attend the meeting personally or virtually may submit any public comments by sending an email to comments@germantownwi.gov by 4 p.m. on the day of the meeting so that it can be provided to the members of the body for their consideration.

AGENDA

- I. **CALL TO ORDER:** *This meeting has been given public notice in accordance with Section 19.83 and 19.84, Wis. Stats, in such form that will apprise the general public and news media of subject matter that is intended for consideration and action.*
- II. **ROLL CALL:**
- III. **CITIZEN INPUT:** *(Please be advised per 19.84(2) that information and comment will be received from the public. It is the policy of this municipality that public input be limited to a four (4) minute period per person with a time extension granted at the discretion of the Chairperson. Be advised that there may be limited discussion of the information received but no action will be taken under public comments.) Comments that may be injurious to village personnel or other individuals will not be allowed.*
- IV. **MEETING MINUTES:**
 - A. May 21, 2025 (action)
- V. **UNFINISHED BUSINESS:**
- VI. **NEW BUSINESS:**
 - A. Updates to the Germantown Area Veteran's Memorial (discussion)
 - B. Friedenfeld Park (action)
 - C. Activity Fee Increase (action)
- VII. **SCHOOL BOARD REPORT:**
- VIII. **DIRECTOR'S REPORT:**
 - A. Directors' Report (discussion)
 - B. Recreation Report (discussion)
- IX. **ANNOUNCEMENT OF PUBLIC INTEREST:**
 - A. The next regularly scheduled Park & Recreation Commission meeting will be on August 20, 2025 at 5:30 PM.
- X. **ADJOURNMENT:**

UPON REASONABLE NOTICE, efforts will be made to accommodate the needs of disabled individuals through appropriate aids and services. For additional information or to request this service, please contact the Village Clerk at (262)250-4745 at least 2 days prior to the meeting.

Notice is hereby given that a possible quorum of other boards, committees, and/or commissions may attend this meeting to gather information about an item over which they have decision-making responsibility. This may

PARK & RECREATION COMMISSION AGENDA

July 16, 2025

Page 2

constitute a meeting of these bodies per State ex rel. Badke v Greendale Village Board, even though these bodies will not take formal action at this meeting.

MEETING:	REGULAR MEETING OF THE PARK & RECREATION COMMISSION
DATE AND TIME:	Wednesday, May 21, 2025 5:30 PM
LOCATION:	Germantown Village Hall Board Room N112 W17001 Mequon Road

MINUTES

I. **CALL TO ORDER:** *This meeting has been given public notice in accordance with Section 19.83 and 19.84, Wis. Stats, in such form that will apprise the general public and news media of subject matter that is intended for consideration and action.*
The meeting was called to order by Chairperson Depies at 5:32 PM

II. **ROLL CALL:**
Present: Committee Member Brian Depies, Committee Member Virginia Smith, Committee Member Steve Stapleman, Committee Member Tracy Pawlak, Trustee Meg Cutts, Committee Member Monica Stiebs
Also Present: Administrator Steve Kreklow

III. **APPROVAL OF MINUTES:**
Park & Recreation Meeting Minutes for April 16, 2025
Motion: Approve as presented
Motioned By: Tracy Pawlak
Seconded By: Virginia Smith
Yes: Brian Depies, Steve Stapleman, Virginia Smith, Tracy Pawlak
No: None
Abstain: Meg Cutts, Monica Stiebs
Motion Passed (Yes 4, No 0, Abstained 2)
A. April 16, 2025 Minutes - (Action Item)

IV. **CITIZEN INPUT:** *(Please be advised per 19.84(2) that information and comment will be received from the public. It is the policy of this municipality that public input be limited to a three (3) minute period per person with a time extension granted at the discretion of the Chairperson. Be advised that there may be limited discussion of the information received but no action will be taken under public comments.) Comments that may be injurious to village personnel or other individuals will not be allowed. Residents that spoke are the following: Melanie Smythe on Ceder Lane JeEtte Tennes on Augusta Court John Pendergast on Camino Drive*
Residents that spoke are the following:
Melanie Smythe (N140W17938 Ceder Lane) - land exchange
JeEtte Tennes (N117W17820 Augusta Court) - land exchange
John Pendergast W168N11475 El Camino Drive) - Chairperson Depies read email - land exchange

V. **NEW BUSINESS:**

A. Potential Land Exchange Between Blackstone Golf Course and Village of Germantown - Action Item

Village Administrator Kreklow presented a recap on the potential land exchange between Blackstone Golf Course and the Village of Germantown. He would like the Park & Recreation Commission to give directions to the Village Board on how they should proceed and if they should move forward with any type of negotiations, and what those negotiations should look like.

Discussion followed

golf course could be utilized to benefit the Village

expand current activities

create a larger space for Music at the Pivilion

future home for a larger splash pad or aquatic facility.

questions regarding maintenance

Menomonee River Trail Plan and having public access to the Menomonee River Corridor

a master plan

not having any or little distribution to the skate park, pickle ball courts and play area

hire a professional park planner and floodplain engineer.

appraisal would need to be completed on all parcels, but the Village Board is looking for direction

prioritization that the commission would like to see the Village Board negotiate in the proceedings

getting input from the neighbors to see what type of use would be most acceptable

Motion: To recommend that the Village Board enter into negotiations for the land exchange with Blackstone Creek

Motioned By: Tracy Pawlak

Seconded By: Steve Stapleman

Yes: Brian Depies, Steve Stapleman, Virginia Smith, Tracy Pawlak, Monica Stiebs

No: Meg Cutts

Abstain: None

Motion Passed (Yes 5, No 1, Abstained 0)

B. Update on Goldendale Creek Property - (Discussion Only)

Administrator Kreklow gave an updated presentation on the Goldendale Creek property/MMSD Basin Program. The Village recently completed the transfer of that property from MMSD to the Village. This is part of the core recreational trail plan and a trail is planned to go through that land.

A new road will be constructed next to that land over the summer from Holy Hill going south to the railroad tracks to accommodate the construction of Truck Country. The contractor that is constructing the road would like to construct a staging area on the property that was acquired from MMSD. This area would be gravel, possibly asphalt, and could then be utilized for parking, so the public would have access to the land that is planned to be developed. Future planning should take place in the 2026 budget for this area. MMSD has the Lamm parcel of land that will be turned over to the Village at some point. The Lamm parcel is about a 40-acre parcel on Maple Road.

This item is for information only.

VI. **SCHOOL BOARD REPORT:**

Commissioner Pawlak presented the school board report. The building and ground review has been completed and is now being reviewed and building visits will take place over the summer. The district is planning to hold more building and grounds meetings more frequently over the summer. The school board will be adjusting their monthly meeting to now meet on Tuesdays. This item is for information only.

VII. DIRECTOR'S REPORT/RECREATION REPORT

A. Directors report (discussion)

Director Sandridge gave his directors' report

The 21st annual Arbor Day took place on April 25, 2025, at Spassland Park.

Glow Walk took place on May 2, 2025, at Kinderberg Park.

Kinderberg Park gates were installed. The remaining landscaping work is still being completed by Total Lawn Care.

Kinderberg Park sustained close to \$3,000 in vandalism damage to the men's restroom. Repairs have been completed, and a camera system is being looked into. Kinderberg Park Spashpad - Carrico Aquatics have completed their work on the pump house. DPW has contracted a company that will clean out the line, strip and repaint the surface.

With the police department not being able to distribute keys to our facilities over the weekend, we have developed a new system where patrons who will need keys to our facilities will be able to come to the Village Hall to pick up those keys. This system will go into effect in June.

The Farmers Market began on May 3rd. We have 23 vendors that have signed up so far.

Music at the Pavilion has already generated over \$35,000 in sponsorship fees, six bands at a cost of \$31,000 plus the sound and lighting technician.

Last year we grossed over \$14,000 in beverage sales.

Field improvements have been completed at Kindeberg. The fence and dugouts project will be completed once the baseball season is completed.

I will be going to the board shortly to discuss the outdoor shelter at Fireman's Park and the renovation of the Firestation.

This item is for information only.

B. Recreation report (discussion)

Director Standridge gave the recreation report

We have 32 programs that have started

Movie in the Park will be coming soon

The summer Kids Klub will be starting in June with all of our sites already filled, and we are taking names for our waitlist.

This item is for information only.

VIII. ANNOUNCEMENT OF PUBLIC INTEREST:

The next regularly scheduled Park & Recreation Commission meeting will be on June 18, 2025, at 5:30 PM.

IX. ADJOURNMENT:

Motion: to adjourn

Motion by: Trustee Cutts

Second by: Committee Pawlak

Yes: Committee members Depies, Stapleman, Smith, Pawlak and Stiebs

No: None

Motion Passes

Meeting adjourned at 7:01 PM



Village of Germantown GIS

DISCLAIMER:

This map is not a survey of the actual boundary of any property this map depicts.

The Village of Germantown Does not guarantee the accuracy of the material contained here in and is not responsible for any misuse or misrepresentation of this information or its derivatives.



Village Of Germantown

N112 W17001 Mequon Road
 Germantown, WI 53022
 262-250-4700



SCALE: 1 = 61'

Print Date: 4/22/2025

Germantown Legion Memorial Renovations

Existing Conditions

Date: 4/22/24

Revisions:

- IFP Set Dated 4/22/25

-
-
-

25'-0"

Crushed Aggregate

Existing Flagpoles, lighting and
plantings to remain

88
5

4'-0" DEEP
CONCRETE BASE
ELEV. 100'-0" TOP OF BASE
(TYPICAL OF 4)

EXISTING TO REMAIN

Crushed Aggregate

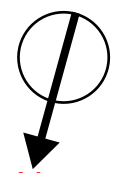
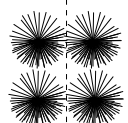
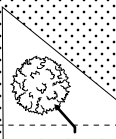

Germantown Legion Memorial Renovations

Proposed Site Plan

Date: 4/22/24

Revisions:

- IFP Set Dated 4/22/25

-
-
-

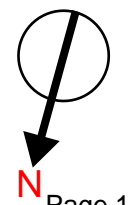
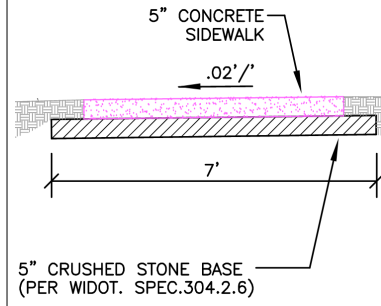
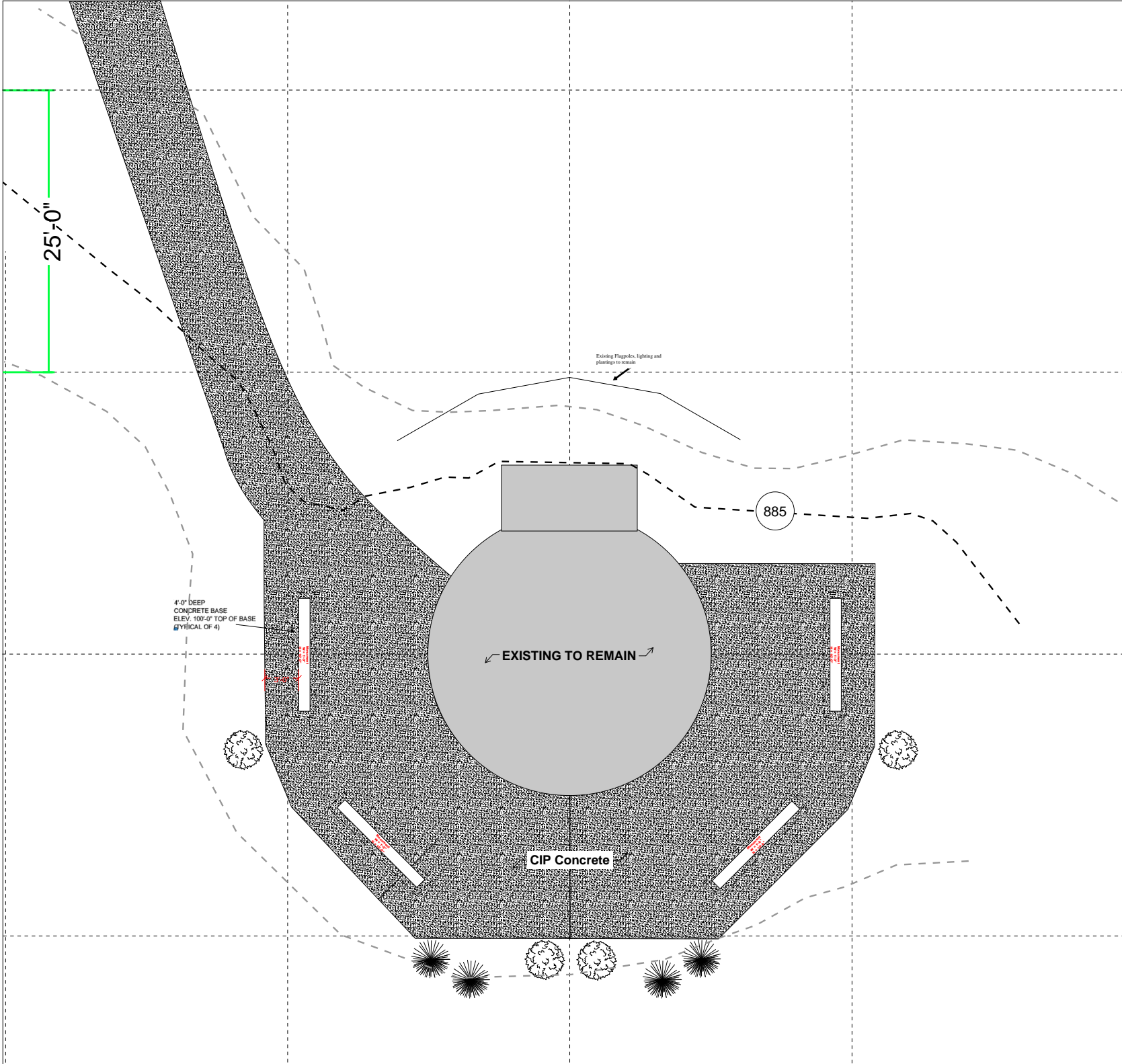

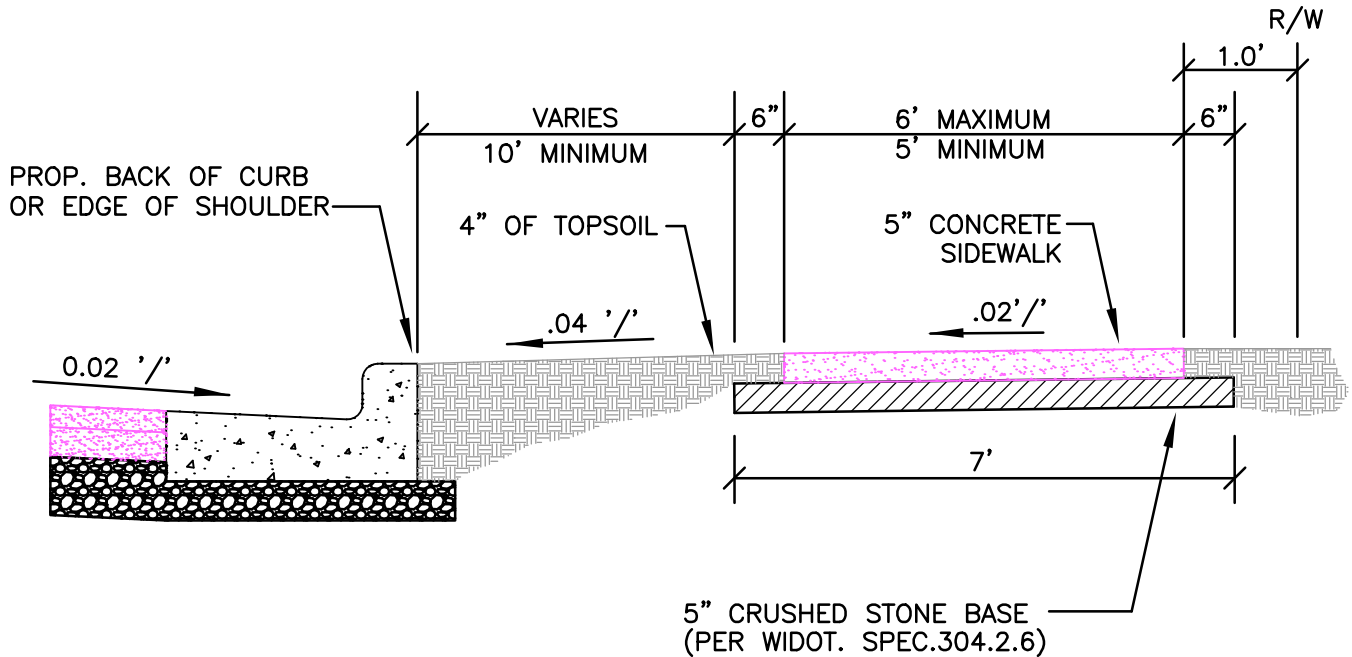

NOTE: THE PROPOSED BACK OF WALK WILL BE LOCATED 1.00' FROM THE EXISTING R/W LINE. CHANGES TO THIS LOCATION CAN BE DONE ONLY WITH PERMISSION OF THE VILLAGE ENGINEER.

ALL DISTURBED TURF ALONG THE NEW SIDEWALK WILL BE RESTORED WITH EITHER 4" OF NEW TOPSOIL AND SOD OR 4" OF NEW TOPSOIL AND HYDROSEED.

TYING NEW SIDEWALK TO EXISTING SIDEWALK WILL BE DONE BY INSTALLING 3-NO. 5 EPOXY COATED REBAR DRILLED IN TO THE EXISTING WALK PAVEMENT AT AN EQUAL SPACING AND A MINIMUM OF 4"

NOT TO SCALE

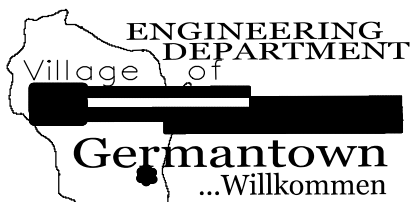

STANDARD DETAIL SIDEWALK DETAIL-CONCRETE

BUSINESS OF THE PARK & RECREATION COMMISSION

MEETING DATE: July 16, 2025

PLACEMENT: Action Item

ITEM TITLE: Friedenfeld Park (action)

SUBMITTED BY:

SUMMARY EXPLANATION:

ATTACHMENT:

1. 2025-07-07_Freidenfeld Park Grading
2. Grade Adjustment Application
3. Letter to P & R Commission Soccer Club 2025 - Copy

STAFF RECOMMENDATION:

ACTION BY COMMITTEE:

**BUSINESS OF THE PARK AND RECREATION COMMISSION
GERMANTOWN, WI**

MEETING DATE: July 7, 2025

AGENDA ITEM: New Business

ITEM TITLE: Freidenfeld Park

SUBMITTED BY:

SUMMARY EXPLANATION:

DJ Frank submitted a yard grade adjustment permit application for grading Freidenfeld park as part of the project for soccer fields.

ATTACHMENT: ORDINANCE____ RESOLUTION____ OTHER__X__

RECOMMENDATION:

Staff requests the Park and Recreation Commission provide feed back and input on the process for a private entity proposing to perform work in the public park.

COMMITTEE ACTION:



Village of

Germantown
...Willkommen

YARD GRADE ADJUSTMENT PERMIT APPLICATION

Date of Application: _____

\$200 Application Fee Received By: _____

Please read and print legibly. List name of actual contact person (NOT just business name).

APPLICANT OR AGENT:

Name: David Kasbeer
 Address: 1120 W21350 Freistadt Rd.
 City/State/Zip: Germantown, WI, 53022
 Phone: 262-894-1654
 E-Mail: david.kasbeer@davidfrank.com

PROPERTY OWNER:

Name: City of Germantown
 Address: Friedenfeld Park, soccer fields
 City/State/Zip: _____
 Phone: _____
 E-Mail: _____

PROPERTY ADDRESS or TAX PARCEL ID#: _____

READ AND INITIAL THE FOLLOWING:

- I understand that Village Staff may request additional information to evaluate this request and failure to provide such information may result in my application being deemed incomplete or sufficient cause to deny the application.
- I understand that Village Staff can impose conditions or other requirements necessary to meet and/or remain in compliance with the Village's Codes and/or other Village requirements that may apply to the subject property.
- I acknowledge that I have completed the Notification to Design Engineer as required under Section 14.078(a)(4).
- I acknowledge that I have completed the Notification to Neighboring Property Owners as required under Section 14.078(a)(5).
- I acknowledge that I have read and understand Chapter 20 of the Municipal Code and Wis. Stats. 68.08 regarding the Administrative Appeal process, and, that any work I perform during the 30 days allowed for an appeal by any aggrieved person(s) is performed at my own risk under Section 14.078(a)(6).
- I understand that the Village Engineer may approve my application, or, may require my application to be reviewed by the Plan Commission or the Public Works & Highway Committee for approval.
- I have read and understand Section 14.078 of the Municipal Code and agree to provide the supporting documents and information required therein and summarized below:

REQUIRED SUPPORTING DOCUMENTS AND INFORMATION TO BE INCLUDED WITH YOUR APPLICATION:

- Narrative Description** see 14.078(a)(1) for specific requirements
- Revised Grading Plan** see 14.078(a)(2) for specific requirements
- \$200 Application Fee** see 14.078(a)(3) for specific requirements

SIGNATURES: ALL APPLICATIONS MUST BE SIGNED

 Applicant Date

 Property Owner Date

VILLAGE USE ONLY

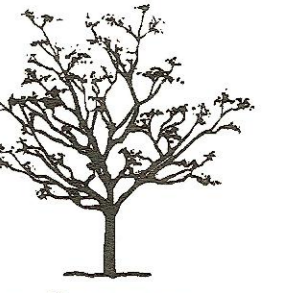

David J. Frank
Landscape Contracting, Inc.

N120 W21360 Freistadt Road
P.O. Box 70
Germantown, Wisconsin 53022
(262) 255-4888 office
mail@davidjfrank.com
davidjfrank.com

LANDSCAPE DEVELOPMENT BY

David Kasbeer
Assistant Landscape Architect

david.kasbeer@davidjfrank.com

LANDSCAPE DEVELOPMENT FOR

Friedenfeld Park

W140N11492 Country Aire Dr
Germantown, Wisconsin 53022

REVISIONS

Δ	DATE	DESCRIPTION

PROJECT NUMBER



0' 10' 20' 40'

SCALE 1" = 20'-0"

DATE 3/25/2025

SHEET 1 of 1

LANDSCAPE PLAN

L1.0

Friedenfeld

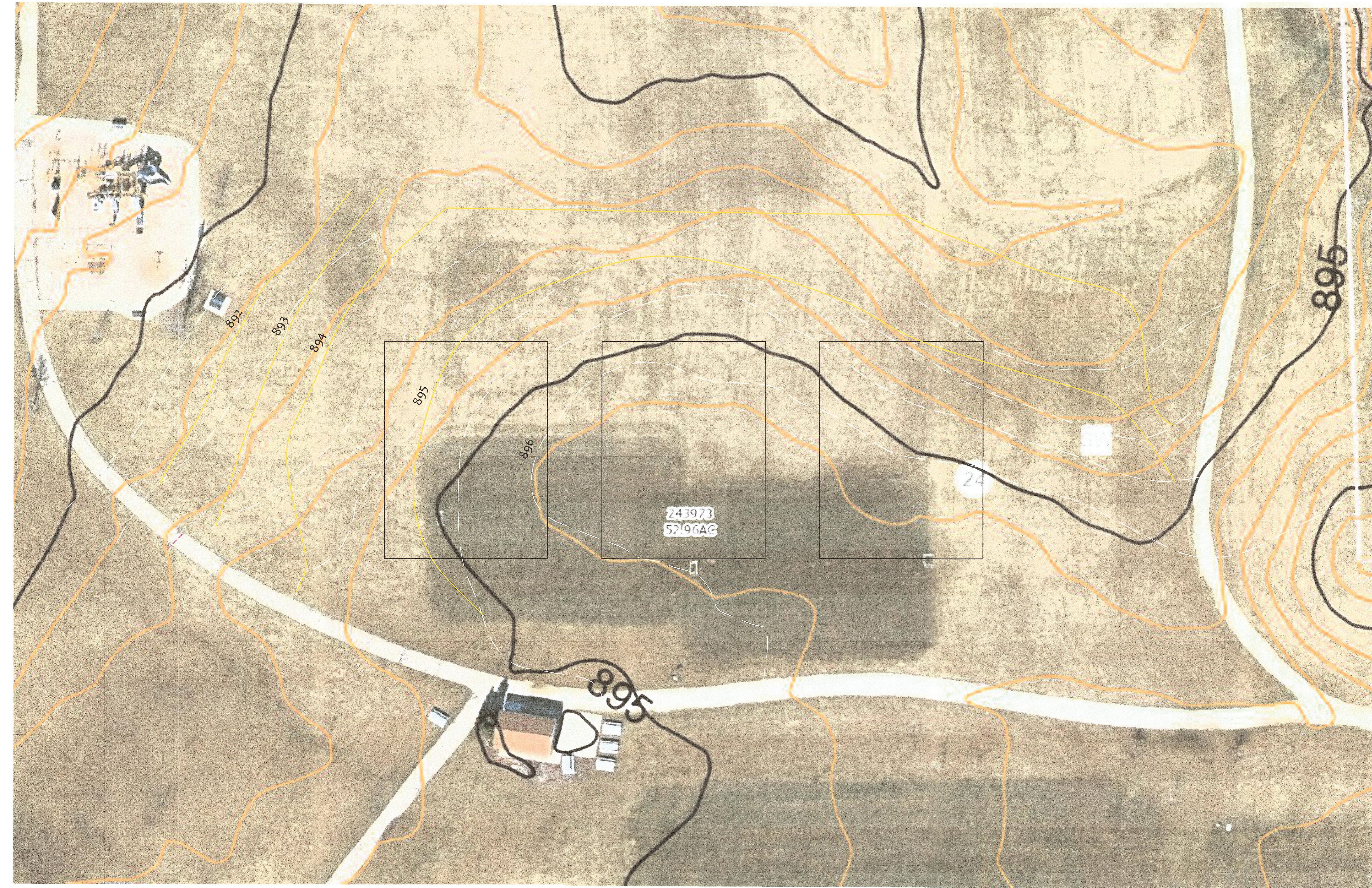

Key

- Existing Topography
- Proposed Topography
- Proposed Soccer Fields

Notes

Solid orange and black lines are contours gathered from online. We surveyed the site ourselves and got more accurate contour lines. Those lines are the dashed gray lines

This drawing is made solely for the individual named herein and is the property of David J Frank Landscape Contracting Inc. Any unauthorized use or duplication is in violation of the copyright laws and subject to prosecution. Plantings, structures, and other representations shown on this plan are for the purpose of conveying landscape design features. Refer to prepared contract documents for specific items included in any particular phase of landscape construction.

A kids soccer league in the city of Germantown is looking to expand some of its fields, but the current grade does not match what a soccer field should be. David J. Frank has been asked to regrade existing soil to meet requirements of a 1 – 2% slope for an athletic field.

Site drawing has topography lines from online however, David J Frank went out and took our own spot elevations to calculate what the slope actually is. Everything is labeled on the drawing to show this, plus proposed topography lines of course. You will see a key at the bottom of the drawing with a reminder in the notes section.

Please reach out with any concerns.

Thanks,

David Kasbeer

David Kasbeer
Associate Landscape Architect

(262) 255- 4888 *office*
(262) 250- 4368 *direct*
(262) 894- 1654 *cell*

david.kasbeer@davidjfrank.com



- (a) **REQUESTS TO ADJUST FINAL YARD GRADES AND PROPOSED CONTOURS.** Requests to adjust final yard grades and proposed contours from those previously accepted by the Village on the master grading plans shall be made via written letter and submitted to the Village Engineer. Written requests shall include the following elements:
- (1) Narrative. The written request shall include a narrative describing the intent and the need for the final yard grade, building elevation and proposed contour adjustments.
 - (2) Revised Grading Plan. The written request shall include a revised grading plan including existing topography contours, proposed final yard grade adjustments, proposed building elevation adjustments, proposed contour adjustments, final drainage patterns, septic system location (if applicable), and existing and proposed final yard grades and building elevations on neighboring lots. The plan shall be presented on a scaled plat of survey.
 - (3) Fees. Fees shall be paid and submitted with the written request. For residential lots, the requestor shall submit a \$200.00 fee for each individual residential lot. For commercial, industrial, institutional and retail buildings, the requestor shall submit a \$200.00 fee for each individual building.
 - (4) Acknowledgement of Notification of Designer. The requestor shall transmit a copy of the above-mentioned request letter, narrative and revised grading plan to the design engineer whose Wisconsin Professional Engineer seal is presented on the master grading plans, and the requestor shall acknowledge in writing that he has completed this task in his written request.
 - (5) Acknowledgement of Notification of Neighboring Property Owners. The requestor shall transmit a copy of the above-mentioned request letter, narrative and revised grading plan to each neighboring property owner, and the requestor shall acknowledge in writing that he has completed this task in his written request.
 - (6) Acknowledgement of Administrative Review Appeals Code and Statute. The requestor shall acknowledge in writing that he is familiar with Chapter 20 of the Municipal Code and §68.08, Wis. Stats., with respect to the administrative review appeal process. The requestor shall also acknowledge in writing that any activity performed by him during the 30 days allowed for appeal by persons aggrieved is performed solely at his own risk.
- (b) **REVIEW OF REQUEST.** The Village Engineering Department shall screen for completeness of the above-listed requirements all requests for adjustments to final yard grades, building elevations and proposed contours. Once determined complete, the Village Engineer shall determine if the request should be reviewed by the Planning Commission or the Public Works and Highway Committee. If Commission or Committee review is, in the judgment of the Engineer, not needed, the Village Engineer shall either accept or deny the completed request within 10 working days from determination of completeness.

VENDOR NO.	VENDOR NAME	CHECK NUMBER
1925	VILLAGE OF GERMANTOWN	687298

TRANSACTION NUMBER	REFERENCE	DATE	DESCRIPTION	GROSS AMOUNT	DISCOUNT	RETAINAGE	PREVIOUS	BALANCE	NET AMOUNT
625 579	062425	06/24/25	PERMIT FEE	200.00	0.00	0.00	0.00	0.00	200.00

VENDOR NO.	GROSS AMOUNT	DISCOUNT	RETAINAGE	PREVIOUS	BALANCE	NET AMOUNT
1925	200.00	0.00	0.00	0.00	0.00	200.00

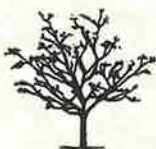

David J. Frank Landscape Contracting, Inc.
 N120 W21350 Freistadt Road
 P.O. Box 70
 Germantown, WI 53022
 (262) 255-4888

WISCONSIN BANK & TRUST
 WWW.WISCONSINBANKANDTRUST.COM
 79-759/759

687298

DATE	CHECK NO.	AMOUNT
06/24/25	687298	\$200.00

Two hundred and xx / 100 Dollars

VILLAGE OF GERMANTOWN
 PAYMENTS C/O US BANK
 PO BOX 78322
 MILWAUKEE WI 53278-8322



[Signature]
 AUTHORIZED SIGNATURE

PAY TO THE ORDER OF

⑈687298⑈ ⑆075907594⑆9661073133⑈

Security features. Details on back



Germantown Park and Recreation Department
N112W17001 Mequon Rd
P.O. Box 337
Germantown, Wisconsin 53022-0337
(262)250-4710 Fax (262)255-2920
Information Line (262)250-4711

Meeting Date: July 16, 2025
To: Parks and Recreation Commission
From: Gil Standridge, Park and Recreation Director
RE: Support for Germantown Soccer Club for field improvements

Parks and Recreation Commission,

I am writing to you in support of the Germantown Soccer Club request to do landscape improvements to the field up in the northeast corner of Friedenfeld (considered the bowl area).

The Germantown Youth Soccer Club has been associated with Parks and Recreation since it's inception back in 1986. The program has seen extensive growth over the years. The program now has over 700 youth participants, making it the largest youth program in Germantown. The Parks and Recreation Department has a lease agreement with the soccer program that is renewed every two years. Currently Soccer pays the village \$20 for every youth participant in the program, per the lease agreement. This money goes towards the landscaping projects in Friedenfeld Park as well as Kinderberg Park and Dheinsville performed by Total Lawn Care.

The Soccer program has fund-raised and sought sponsorships to make improvements to the soccer fields. In particular last year when they completely redid field number six, the large soccer field for older kids. This was a several thousand-dollar project that the club took on to make improvements to the field.

The club is asking for this Commission approval to do landscape work on the northeast corner of the park, not used for any other program, to level out that area with field dirt considering drainage to create more fields for the growing demand of Germantown youth. The club has met with the Village Engineer, Kevin Driscoll and are complying with all the regulations required to do this work.

The additional fields while were included in the feasibility that was done two years ago by Hardwood engineering and approved by this Commission.

Thank you for your consideration. The club will have representation at this meeting to answer any of your questions.

Regards,

Gil Standridge
Parks and Recreation Director
Village of Germantown

BUSINESS OF THE PARK & RECREATION COMMISSION

MEETING DATE: July 16, 2025

PLACEMENT: Action Item

ITEM TITLE: Activity Fee Increase (action)

SUBMITTED BY:

SUMMARY EXPLANATION:

ATTACHMENT:

1. 2025 Fall-Winter Proposed Fees Charges Report

STAFF RECOMMENDATION:

ACTION BY COMMITTEE:

FEES & CHARGES SCHEDULE

Season: Fall/Winter 2025/26

Implementation Date: September 2025

PROGRAM	A-Adult	Y-Youth	T-Teen	PS-Pre-school	TA-Teen/Adult	F-Family	PC-Parent/Child	AY-Adult/Youth	ALL-All ages	NOTES		
TARGET MARKET*	CURRENT FEE	PROPOSED FEE	PROGRAM HOURS	RATE PER ACTIVITY HOUR	% CHANGE	NUMBER ENROLLED	REVENUE	EXPENDITURES	% SUPPORTING	BALANCE		
1st/2nd Grade Buckets	Y	\$57.00	\$62.00	10.00	\$5.70	8.77%	193	\$15,761.77	\$5,335.57	295.41%	\$10,426.20	Fee increase due to facility fees. EARLY BIRD SPECIAL - REGISTER BEFORE 10/24 \$10 LESS
Archery	TYA	\$56.00	\$56.00	4.00	\$14.00	0.00%	10	\$655.00	\$339.50	192.93%	\$315.50	
Art - Henna	AY	\$8.00	\$8.00	1.25	\$6.40	0.00%	16	\$128.00	\$3.84	3333.33%	\$124.16	Co-op with Men Falls. Fee holds spot, remaining \$ owed before class starts to help with budget reductions.
Art Adventure	Y	\$40.00	\$40.00	4.00	\$10.00	0.00%	7	\$698.00	\$421.46	165.61%	\$276.54	
Slice of Art	Y	\$40.00	\$40.00	6.00	\$6.67	0.00%	5					
Afterschool Tech Classes/Legos	Y	\$59.00	\$60.00	4.00	\$14.75	1.69%						Instructor price increase
Legos Schools Out-Stream Sampler Day	Y	\$42/\$67	\$47/\$78	3/6.5	\$14.00/\$10.31	11.90%/16.42%	144	\$7,989.25	\$6,153.25	129.84%	\$1,836.00	Instructor price increase
Babysitters Training	Y	\$70.00	\$70.00	5.50	\$12.73	0.00%	16	\$1,108.00	\$496.19	223.30%	\$611.81	
Barre Fitness	A	\$54.00		6.00	\$9.00		8	\$441.00	\$340.96	129.34%	\$100.04	Not offering this session.
Basic First Aid for Kids	Y	\$10.00	\$10.00	1.00	\$10.00	0.00%	7	\$70.00	\$36.05	194.17%	\$33.95	Same fee as summer, Co-op with Fire Dept
Firefighters are your friends	Y	\$95.00	\$110.00	25.00	\$3.80	15.79%	135	\$15,988.91	\$11,433.55	139.84%	\$4,555.36	EARLY BIRD SPECIAL - REGISTER BEFORE 9/22 \$10 LESS
Bucketeer Basketball	Y	\$95.00	\$110.00	25.00	\$3.80	15.79%	135	\$15,988.91	\$11,433.55	139.84%	\$4,555.36	
Community Band	A	\$25.00	\$30.00	7.00	\$3.57	20.00%	46	\$2,017.24	\$1,512.93	133.33%	\$504.31	Same fee as summer
Dance - Youth	Y	\$85.00	\$95.00	16.75	\$5.07	11.76%	85	\$12,521.98	\$9,595.37	130.50%	\$2,926.61	plus add costume fee of \$60 (up \$5 from last year).
Dance it Out	A	\$57.00	\$58.00	4.50	\$12.67	1.75%	13	\$750.00	\$581.22	129.04%	\$168.78	
Digital Photography Classes	A	\$22.00	\$22.00	2.00	\$7.5/\$9.50	0.00%	7	\$160.00	\$123.62	129.43%	\$36.38	Co-op with Men Falls, they set fees
Fundamental Basketball Camp	Y	\$26.00	\$26.00	1.50	\$17.33	0.00%	40	\$1,047.00	\$760.00	137.76%	\$287.00	
Golf Lessons/Junior Golf Academy	Y/A	\$75.00/\$63.00	\$75.00/\$63.00	7.5/7.5	\$8.8/\$7.47/\$9.33	3.03%/3.57%/28.57%	6	\$408.00	\$188.06	216.95%	\$219.94	
Gtown Kids Choir	Y	\$45.00	\$46.00	16.0	\$2.81	2.22%	32	\$1,760.00	\$829.12	212.27%	\$930.88	
Gymnastics	Y	\$36.00/\$48.00	\$37.00/\$49.00	3/4.5	\$12/\$10.67	2.78%/2.08%	70	\$3,305.50	\$2,339.47	141.29%	\$966.03	
Hoopsters	Y	\$42.00	\$45.00	7.00	\$6.00	7.14%	49	\$2,968.00	\$1,006.53	294.87%	\$1,961.47	
Intro to Hockey 1-2-3	Y	\$10.00	\$10.00	4.50	\$2.22	0.00%	4	\$40.00	\$1.20	3333.33%	\$38.80	Fee holds spot, remaining \$ owed before class starts to help with budget reductions.
Intro to Irish Dance	Y	\$10.00	\$10.00	3.00	\$3.33	0.00%	3	\$30.00	\$0.90	3333.33%	\$29.10	Co-op with Men Falls. Fee holds spot, remaining \$ owed before class starts to help with budget reductions.
Kids Klub	Y	\$11.50	\$11.50	3.00	\$3.83	0.00%	19015	\$202,978.74	\$107,474.09	188.86%	\$95,504.65	Program totals only represent Kids Klub Staff and Supply Expenditures and do not include office support staff, copies, etc.
Kids Klub- All Day	Y	\$28.00	\$30.00	12.00	\$2.33	7.14%						All Day KK is available on full days off throughout the school year that do not fall on a Village holiday. It will be held at County Line Elementary.
Learn to Make Sausage	A	\$10.00	\$10.00	8.00	\$1.25	0.00%	34					Fee holds spot, remaining \$ owed before class starts to help with budget reductions.
Learn to Make Pizza	A	\$10.00	\$10.00	3.50	\$2.86	0.00%	36	\$700.00	\$21.00	3333.33%	\$679.00	Fee holds spot, remaining \$ owed before class starts to help with budget reductions.
Learn to crochet	Y	\$30.00	\$35.00	2.50	\$12.00	16.67%	3	\$98.50	\$63.00	156.35%	\$35.50	same fees as summer
Learn to Skate	Y	\$10.00	\$10.00	3.00	\$3.33	0.00%	8	\$60.00	\$2.40	2500.00%	\$57.60	Fee holds spot, remaining \$ owed before class starts to help with budget reductions.

PROGRAM	A-Adult TARGET MARKET*	Y-Youth CURRENT FEE	T-Teen PROPOSED FEE	PS-Pre-school PROGRAM HOURS	TA-Teen/Adult RATE PER ACTIVITY HOUR	F-Family % CHANGE	NUMBER ENROLLED	PC-Parent/Child REVENUE	AY-Adult/Youth EXPENDITURES	% SUPPORTING	ALL-All ages BALANCE	NOTES
Lego Birthday Parties	Y	\$150.00	\$150.00	0	\$0.00	0.00%	0	\$0.00	\$0.00		\$0.00	The fee is \$15 per person with a minimum of 10 students. This will include use of the facility for 2 hours.
Men's Over 30 Open Basketball	A	\$5.00	\$5.00	2.00	\$2.50	0.00%	varies by week	\$2,785.00	\$2,019.00	137.94%	\$766.00	
Mini Golf League Adult	AT	\$32.00	\$34.00	6.00	\$5.33	6.25%	15					
Mini Golf League Youth	Y	\$22.00	\$24.00	6.00	\$3.67	9.09%	32	\$ 1,354.00	\$ 867.00	156.17%	\$487.00	
Miss Julie's Music Fun/ Parties/families/Babies	PS	\$57/\$14/\$18/\$10	\$57/\$14/\$18/\$10	3.75/1/1/50	\$14.67/16/18/16	3.64%/16%/12%/25%	84	\$1,786.10	\$1,485.90	120.20%	\$300.20	Co-op with Men Falls.
Oodles of Art	PS	\$42.00	\$42.00	4.00	\$10.50	0.00%	13	\$506.00	\$384.35	131.65%	\$121.65	
Open Pickleball	A	\$6.00	\$7.00	2.00	\$3.50	16.67%	varies by week	\$896.00	\$777.99	115.17%	\$118.01	
Parent/Child Basketball	PC	\$30.00	\$30.00	2.25	\$13.33	0.00%	23	\$720.00	\$435.80	165.21%	\$284.20	same fee as summer
Pilates Mat	A	\$8.00	\$8.00	5.0	\$1.60	0.00%	9	\$112.00	\$2.16	5185.19%	\$109.84	Fee holds spot, remaining \$ owed before class starts to help with budget reductions.
Pom Pons	Y	\$34/\$53/\$130/\$140	\$36/\$55/\$134/\$144	5hrs/10hrs/20hrs	\$7.20/\$5.50/6.70/7.20	5.88%/3.77%/3.08%/2.86%	141	\$8,467.00	\$6,205.00	136.45%	\$2,262.00	Pixie/Spark/Power registering in fall for both sessions so fees combined.
Holiday Patio Planter Workshop/Succulent Pumpkin	A	\$8.00	\$8.00	1.0	\$8.00	0.00%	49	\$392.00	\$11.76	3333.33%	\$380.24	Co-op with Men Falls. Fee holds spot, remaining \$ owed before class starts to help with budget reductions.
Selling/Buying a Home or Condo	A	FREE	FREE	1.50		0.00%	2	\$0.00				Co-op with Men Falls.
Stay Home Alone	Y	\$38.00	\$40.00	4.00	\$9.50	5.26%	12	\$444.00	\$164.88	269.29%	\$279.12	Co-op with Men. Falls. Same fees as summer.
Tae Kwon Do for Kids/Families	Y/F	\$25.00/\$50.00	\$30.00/\$55.00	4.00	\$3.33/\$6.11	20%/10%	8	\$253.00	\$9.00	2811.11%	\$244.00	same fees as summer.
Team Training	A	\$56.00		9.00	\$0.00		0	\$0.00	\$0.00		\$0.00	No longer offering.
Therapy Dog Screening	A	\$12.00		1.00	\$12.00	-100.00%	7	\$77.00	\$2.52	3055.56%	\$74.48	No longer offering, instructor has retired
Tot Time	Y	\$7.00	\$7.00	1.50	\$4.67	0.00%	102	\$630.00	\$21.24	2966.10%	\$608.76	
Tree Climbing	AY	\$47.00	\$48.00	2.00	\$23.50	2.13%	10	\$480.00	\$374.10	128.31%	\$105.90	same fee as summer
Wellness Workshops	A	FREE	FREE	1.00	\$0.00	0.00%	0					Dr. Brenda Holland offers Wellness Workshops. She had to have kenne surgery last fall in which we had to cancel fall classes.
Yoga	AT	\$10.00	\$10.00	4.0	\$2.50	0.00%	21	\$210.00	\$6.30	3333.33%	\$203.70	In conjunction with Surge. Fee holds spot, remaining \$ owed before class starts to help with budget reductions.
Youth & Little Tykes Martial Arts	Y	\$10.00	\$10.00	4.00	\$2.50	0.00%	7	\$70.00	\$2.10	3333.33%	\$67.90	In conjunction with Surge. Fee holds spot, remaining \$ owed before class starts to help with budget reductions.
TOTALS								\$290,866.99	\$161,828.38	179.74%	\$129,038.61	
NEW PROGRAMS												
Core & Pelvic Floor 101	A		\$16.00	1.00	\$16.00							Discover why proper pelvic floor and core training is crucial for your daily life. You'll also learn simple, effective pelvic floor exercises you can start today. Same fee as summer.
Dance & Craft Workshop	Y		\$23.00	2.00	\$11.50							Party for the younger kids. Make some crafts related to the theme and then learn some dance moves! Same fee as summer.
Holiday Gift Making	Y		\$40.00	3.00	\$13.33							Youth will make home made holiday gifts that include fiber art, sewing, weaving and ornament making.
Kickbox Fitness	A		\$10.00	4.00	\$2.50							Co-op with Surge Fitness. LEARN - proper and efficient kickboxing movements,BURN - calories, stress & insecurities away, BUILD - Strength, confidence, endurance, & skill.Fee holds spot, remaining \$ owed before class starts to help with budget reductions.

	A-Adult	Y-Youth	T-Teen	PS-Pre-school	TA-Teen/Adult	F-Family		PC-Parent/Child	AY-Adult/Youth		ALL-All ages	
PROGRAM	TARGET MARKET*	CURRENT FEE	PROPOSED FEE	PROGRAM HOURS	RATE PER ACTIVITY HOUR	% CHANGE	NUMBER ENROLLED	REVENUE	EXPENDITURES	% SUPPORTING	BALANCE	NOTES
Soma Breath for Health/Energized Meditation	A		\$8.00	4.00	\$2.00							Learn simple daily practices to improve your breath health and increase physical wellbeing while decreasing stress. Also held in spring. Fee holds spot, remaining \$ owed before class starts to help with budget reductions.

Directors Report
Park and Recreation Commission
July 16,2025

4th of July Celebration:

From Staff perspective the parade and the fireworks went off without an issue. Friday morning early there was a scare of cancelling the parade due to lightning and thunder and rain. However, by the time parade participants started showing up and getting organized, the thunder/lightning stopped and rain stopped as well. Staff had to make a couple of adjustments to the order of the parade participants, but all went well. There were 40 parade participants.

The streets all along the parade route were lined up with spectators on both sides of the road, from Start to finish.

Some complaints were the parade started too early and there weren't enough parade participants. But most of the comments received were very positive.

The Fireworks show started around 9:15 pm to a packed park. Comments were that our fireworks show was much better, and longer than other village/city shows that were on different nights than the fourth. The village paid for a 30-minute show, but we received a 40-45-minute show.

The American Legion/VFW sold food and beverages at the Fireman Park indoor shelter. They made a nice profit as they were not charged to use the facility. Profits were going to the Memorial Wall restoration and additions. The complaint from the public is that American Legion ran out of food early that evening, and folks were disappointed that they couldn't get a burger or other food products.

Complaints about the program from public: No games for the kids. No concert or music. Not enough food vendors. Hopefully the Board will recognize these complaints, and a committee of volunteers will pick up the complete program next year.

Music at the Pavilion Update:

The first two concerts, Love Monkeys and Cherry Pie drew between 2000-2500 each concert with around \$13,000 in beer sales. Our third concert, 33RPM drew between 1500-2000. I believe the major reason for this was it rained heavily that afternoon before the concert. Then during the concert, we had about a 15-20-minute delay due to rain. I believe this hurts us attendance wise. Also, due to the rain our beer sales were down a bit to probably \$3200 but were still good considering the weather and the lesser crowds.

Our next Concert if July 17th, Rebel Grace, and we anticipate one of our largest crowds to attend this weather permitting. So should be a revenue producing night for our department.

Fridenfeld Park Sign:

The sign that was vandalized back in February has now been replaced with a new sign and posts. The sign looks identical to the old sign and was designed and built by the same sign company. Public Works put the posts in the ground. This project came at a cost of around \$6000 altogether.

Kids Klub Carnival:

In conjunction with the Taste of Germantown, a fund raiser for the Kiwanis, our department will be sponsoring a kid's carnival on Thursday July 24th starting at 5pm. The carnival will be held down by the old picnic shelter. Tickets must be purchased to participate in the games, bouncy houses, and other activities being put on. Some of these other activities include balloon artists, and face painters, who are always popular with the kids. We are looking for volunteers to help us man a

game or a blown-up bouncy house or obstacle course. The program starts at 5pm and will go until dark.

The Kiwanis will have food vendors, a beer tent (at the indoor shelter), and live music until 9pm. The money raised by Kiwanis also helps sponsor several organizations within Germantown.

2026 Budget:

I am currently setting up meetings with staff to review our expenditure for 2025, and our needs for 2026. All departments are being asked to reduce their seasonal and part-time staff by 5%. Not being asked to cut our expense and supplies line, yet. But cutting back 5% is approximately \$17,000. So will have to look at cutting some of our programs most likely.

In our August meeting I can present our budget we wish to present to the board. Right now, the process is just starting so not much to report as far as the budget.

Land Swap:

This commission approved allowing the process to start discussion about land swaps with the golf course owners wanting 8 acres out of the Haupt Strasse park for development. This went before the board the other night, Monday, at the board meeting. The Board agreed to allow Steve to start doing assessments of land value, as well as engineering reports on developing on the flood plain and so forth. One of the first things the Board wants to put into the golf course IF all this goes through is replacement of the pickleball courts at Haupt Strasse and the skate park. I met with a representative from Munson (fencing, and now tennis, pickleball, basketball courts) who is going to come up with some figures of what it would cost to replace the pickleball courts and skateboard court. I will be meeting with a skateboard company to come up with a cost estimate to put in a skate park, similar in size to the one we will lose if this deal does go through. Keep in mind nothing is set in concrete. Just trying to get an idea of replacement costs for future budget considerations if the land swap goes through legally.

Senior Advisory Board:

This year we had two advisory board members on the Senior Advisory board step down which left us without a quorum. Fortunately, Lynn Bracy and Barb Borken, both active participants at the Senior Center, stepped up to be part of the Advisory Board. Also, some of the club constitutions were changed and accepted by the Board of Trustees. Instead of having three Trustees on the advisory board, that was changed to only one Trustee (Jan Miller) was required to serve. So now the advisory board that meets again on the 17th of this month has a full quorum.

Recreation Division Report July, 2025 Commission Meeting

We have 30 programs starting in July along with the over 30 programs that are ongoing throughout the summer and include: Art Adventure Camp, Martin Skills Academy, Pickleball, Jr Golf Academy, Little Tykes Martial Arts, Youth Martial Arts, Booster Night, Hot Wheels Inline Skating, Tae Kwon Do, Girls Basketball Camp, Music Fun, Music Fun Families/Babies, Tennis – session 2, Intro to Irish Dance, Learn to Crochet, Girls Volleyball Camps, Learn Magic, Learn Not to Burn, Stay Home Alone, Yoga, Fit in Parks Mindful Movement, Fit in Parks Dance it Out, Fit in Parks Hatha Yoga, Fit in Parks Pilates, Fit in Parks – Family Tae Kwon Do, Fit in Parks Soma Breathwork Meditation, Kids Triathlon, Family Carnival Night, Henna Tattoos, Learn to Ice Skate/Hockey, Music at the Pavilion, Community Band Concerts.

Ongoing Programs: Gymnastics, Kids Klub (4 sites), Tyke Site (Plus/Traditional), Night & Daytime Jr and Sr Tball Leagues, Wrestling, Golf, Men's Open Basketball, Minors/Majors Baseball, Girls Softball, Spikers/Setters/Diggers, Fun Game Frenzy, Sporties for Shorties, Outdoor Basketball, Rugby, Band Rehearsals, Tennis – Jr/HS Lg, Adults, Cardio, lessons.

4th of July: The rain cleared just in time for the parade line up. We had 40 units in the parade just like last year. Special thanks to those commission members who helped that day, it was greatly appreciated.

Upcoming events include the following:

Movies in the Park: In June we featured the movie Moana 2, and it was well attended with 150 in the audience. Our next movie will be on Friday, August 15th featuring The Wild Robot. Both movies are held at Firemen's Park. Special thanks to our sponsor Bank 59.

Booster Night: Booster Night was held on July 7th and Robert's Frozen Custard donated \$325.00 towards our programs!

Family Fun Carnival Night: Families can enjoy carnival games and inflatables. Event will be held on Thursday, July 24th from 5:00 – 9:00 p.m. at Firemen's Park. It will be held in conjunction with the Taste of Germantown. We need more volunteers to help, if you are around it would be greatly appreciated.

Fit in Parks: Fit in Parks has been a huge success again this year. We received a grant from Froedtert Health for \$1,000 to go towards the Fit in Parks Program!

Music at the Pavilion: The entire event is sponsored by Waste Management, North Shore Bank, Truck Country, and Window World. We have over 20 sponsors this year! Remaining bands include Rebel Grace, The Britins, and Bella Cain.

Kids Triathlon: We have 68 kids signed up for the event. Special thanks to our sponsors WFA Staffing, Life Balance, Kiwanis, Yentz Family Chiropractic, Jacked Up, & Blair Fire Protection. We hope it will be a great day! We could use more volunteers if anyone has the time. Also, thanks to the Fire Dept. who will spray the kids off when they are done!