

MEETING: ***AMENDED* REGULAR MEETING OF THE PUBLIC SAFETY COMMITTEE**

DATE & TIME: **Monday, January 5, 2026 at 6:00 PM**

LOCATION: **Germantown Village Hall Board Room
N112 W17001 Mequon Road**

Any member of the body and/or citizen may attend the meeting virtually through the WebEx platform, Meeting #: **2558 465 8452** Password: **qdSbcjjG635** which can be accessed by phone at **408-418-9388** or by logging on at <https://villageofgermantown.my.webex.com/villageofgermantown.my/j.php?MTID=m204b707e6b5e066bdaca1dd7b534d24e>

Citizens not wishing to attend the meeting personally or virtually may submit any public comments by sending an email to comments@germantownwi.gov by 4 p.m. on the day of the meeting so that it can be provided to the members of the body for their consideration. Previously recorded Village Board Meeting Videos can be viewed at https://www.youtube.com/channel/UCOYp0EgELzTCa9X_iCohyhQ.

AGENDA

- I. **CALL TO ORDER:** *This meeting has been given public notice in accordance with Section 19.83 and 19.84, Wis. Stats, in such form that will apprise the general public and news media of subject matter that is intended for consideration and action.*
- II. **ROLL CALL:**
- III. **CITIZEN INPUT:** *(Please be advised per 19.84(2) that information and comment will be received from the public. It is the policy of this municipality that public input be limited to a four (4) minute period per person with a time extension granted at the discretion of the Chairperson. Be advised that there may be limited discussion of the information received but no action will be taken under public comments.) Comments that may be injurious to village personnel or other individuals will not be allowed.*
- IV. **MEETING MINUTES:**
 - A. December 1, 2025 (ACTION)
- V. **DECEMBER 2025 REPORTS (Discussion)**
 - A. Police Monthly Report
 - B. Fire Department Monthly Report
 - C. Overtime Report
- VI. **REPORTS (Discussion Unless Otherwise Noted):**
 - A. Police Monthly Report
 - B. Fire Department Monthly Report
 - C. Overtime Report
 - D. Policy Updates
- VII. **UNFINISHED BUSINESS:**
- VIII. **NEW BUSINESS:**
 - A. Rifle Suppressor purchase for 25 rifles (ACTION)
 - B. ProPhoenix Records Management Maintenance and Support for 2026 (ACTION)

- C. Lexipol Policy Management Support for 2026 (ACTION)
- D. GFD Staff Command Vehicle Purchase (ACTION)
- E. ***A contract with Short Elliot Hendrickson (SEH) for design and construction inspection services related to the Fire Station #2 remodel and expansion. (ACTION)***

IX. ADJOURNMENT:

UPON REASONABLE NOTICE, efforts will be made to accommodate the needs of disabled individuals through appropriate aids and services. For additional information or to request this service, please contact the Village Clerk at (262)250-4745 at least 2 days prior to the meeting.

Notice is hereby given that a possible quorum of other boards, committees, and/or commissions may attend this meeting to gather information about an item over which they have decision-making responsibility. This may constitute a meeting of these bodies per State ex rel. Badke v Greendale Village Board, even though these bodies will not take formal action at this meeting.

MEETING:	REGULAR MEETING OF THE PUBLIC SAFETY COMMITTEE
DATE AND TIME:	Monday, December 1, 2025 6:00 PM
LOCATION:	Germantown Village Hall Board Room N112 W17001 Mequon Road

MINUTES

- I. **CALL TO ORDER:** *This meeting has been given public notice in accordance with Section 19.83 and 19.84, Wis. Stats, in such form that will apprise the general public and news media of subject matter that is intended for consideration and action.*

Chairperson Trustee Meg Cutts called the Public Safety Committee meeting to order at 6:09 PM.

II. **ROLL CALL:**

Present: Trustee Meg Cutts, Trustee Jolene Pieper (via WebEx), Trustee David Baum (via phone until in-person arrival at 6:15 PM)

Excused: Trustee Kristen Borst

Also Present: Fire Chief John Delain, Police Chief Pat Merten, Village Clerk Donna Ott, Finance Director Matthew Uselding, Village Administrator Steve Kreklow

- III. **CITIZEN INPUT:** *(Please be advised per 19.84(2) that information and comment will be received from the public. It is the policy of this municipality that public input be limited to a four (4) minute period per person with a time extension granted at the discretion of the Chairperson. Be advised that there may be limited discussion of the information received but no action will be taken under public comments.) Comments that may be injurious to village personnel or other individuals will not be allowed.*

Melanie Smythe (N140W17938 Cedar Ln) spoke regarding New Business Item E (Discussion on County Proposal for a County-wide EMS System).

Scott Hefle (W159N10514 Old Farm Rd) spoke regarding the fire incident report, New Business Item G (Update of Police Officer Lateral Transfer side letter with GPPA), the K9 Squad, and the Village budget.

Lynne Schauer Bednarz (W156N10121 Pawnee Ct) spoke regarding the Village budget.

Chairperson Trustee Cutts read the following emailed comment into the record:

- Bill and Carol Schneider submitted comments regarding the Village budget, the Flower Source property, and the Fire Department.

IV. MEETING MINUTES:

A. November 3, 2025

Motion: Approve as presented

Motioned By: Jolene Pieper

Seconded By: David Baum

Yes: Meg Cutts, Jolene Pieper, David Baum

No: None

Abstain: None

Motion Carried by Voice Vote (Yes 3, No 0, Abstained 0)

V. REPORTS (Discussion Unless Otherwise Noted):

Motion: Move Reports to the end of the Agenda to discuss if time allows

Motioned By: Jolene Pieper

Seconded By: David Baum

Yes: Meg Cutts, Jolene Pieper, David Baum

No: None

Abstain: None

Motion Carried by Voice Vote (Yes 3, No 0, Abstained 0)

A. Police Monthly Report

B. Fire Department Monthly Report

C. Overtime Report

D. Policy Updates

VI. UNFINISHED BUSINESS:

VII. NEW BUSINESS:

Motion: Discuss New Business Items A, B, and F first

Motioned By: David Baum

Seconded By: Jolene Pieper

Yes: Meg Cutts, Jolene Pieper, David Baum

No: None

Abstain: None

Motion Carried by Voice Vote (Yes 3, No 0, Abstained 0)

A. Renewal Applications for an Animal Fancier's Permit for 2026

1. Applicant Maureen Shaughnessy (ACTION)

Motion: Approve as presented

Motioned By: Jolene Pieper

Seconded By: David Baum

Yes: Meg Cutts, Jolene Pieper, David Baum

No: None

Abstain: None

Motion Carried by Voice Vote (Yes 3, No 0, Abstained 0)

2. Applicant Becky Rao (ACTION)

Motion: Approve as presented

Motioned By: Jolene Pieper

Seconded By: David Baum

Yes: Meg Cutts, Jolene Pieper, David Baum

No: None

Abstain: None

Motion Carried by Voice Vote (Yes 3, No 0, Abstained 0)

3. Applicant Mary Best (ACTION)

Motion: Approve as presented

Motioned By: Jolene Pieper

Seconded By: David Baum

Yes: Meg Cutts, Jolene Pieper, David Baum

No: None

Abstain: None

Motion Carried by Voice Vote (Yes 3, No 0, Abstained 0)

B. Renewal Applications of Secondhand Jewelry Dealer and Secondhand Article Dealer Licenses for 2026

1. Kesslers Diamond Center, Inc - Secondhand Jewelry and Secondhand Article Dealer (ACTION)

Motion: Approve as presented
Motioned By: Jolene Pieper
Seconded By: David Baum

Yes: Meg Cutts, Jolene Pieper, David Baum
No: None
Abstain: None

Motion Carried by Voice Vote (Yes 3, No 0, Abstained 0)

2. National Rarities LLC - Secondhand Jewelry Dealer and Secondhand Article Dealer (ACTION)

Motion: Approve as presented
Motioned By: Jolene Pieper
Seconded By: David Baum

Yes: Meg Cutts, Jolene Pieper, David Baum
No: None
Abstain: None

Motion Carried by Voice Vote (Yes 3, No 0, Abstained 0)

3. ecoATM, LLC - Secondhand Article Dealer (inside Walmart W190N9855 Appleton Ave) (ACTION)

Motion: Approve as presented
Motioned By: Jolene Pieper
Seconded By: David Baum

Yes: Meg Cutts, Jolene Pieper, David Baum
No: None
Abstain: None

Motion Carried by Voice Vote (Yes 3, No 0, Abstained 0)

- F. Request to Order & Purchase of squad cars for 2026 budget year(ACTION)

Motion: Approve as presented
Motioned By: Jolene Pieper
Seconded By: David Baum

Yes: Meg Cutts, Jolene Pieper, David Baum
No: None
Abstain: None

Motion Carried by Roll Call Vote (Yes 3, No 0, Abstained 0)

- C. 2025 Fire Department Budget Amendment to account for grant proceeds that offset previously unbudgeted expenditures (ACTION)

Motion: Approve as presented

Motioned By: Jolene Pieper

Seconded By: David Baum

Yes: Meg Cutts, Jolene Pieper, David Baum

No: None

Abstain: None

Motion Carried by Roll Call Vote (Yes 3, No 0, Abstained 0)

- D. 2025 Fire Department Budget Amendment to account for County grant proceeds that offset previously unbudgeted expenditures (ACTION)

Motion: Approve as presented

Motioned By: Jolene Pieper

Seconded By: David Baum

Yes: Meg Cutts, Jolene Pieper, David Baum

No: None

Abstain: None

Motion Carried by Roll Call Vote (Yes 3, No 0, Abstained 0)

- E. 2025 Police Department Budget Amendment to account for insurance proceeds that offset previously unbudgeted expenditures (ACTION)

Motion: Approve as presented

Motioned By: Jolene Pieper

Seconded By: David Baum

Yes: Meg Cutts, Jolene Pieper, David Baum

No: None

Abstain: None

Motion Carried by Roll Call Vote (Yes 3, No 0, Abstained 0)

- G. Update of Police Officer Lateral Transfer side letter with GPPA (ACTION)

Motion: Approve as presented

Motioned By: Jolene Pieper

Seconded By: David Baum

Yes: Meg Cutts, Jolene Pieper, David Baum

No: None

Abstain: None

Motion Carried by Roll Call Vote (Yes 3, No 0, Abstained 0)

H. Update of K9 Side Letter Agreement with GPPA (ACTION)

Motion: Approve as presented

Motioned By: Jolene Pieper

Seconded By: David Baum

Yes: Meg Cutts, Jolene Pieper, David Baum

No: None

Abstain: None

Motion Carried by Roll Call Vote (Yes 3, No 0, Abstained 0)

I. Renewal of FLOCK Camera 5-year contract (ACTION)

Motion: Approve as presented

Motioned By: Jolene Pieper

Seconded By: David Baum

Motion Withdrawn.

Motion: Petition Menomonee Falls and Washington County for help paying these costs or sharing services

Motioned By: Jolene Pieper

Seconded By: None

Motion Failed for lack of a second.

Motion: Approve as presented

Motioned By: David Baum

Seconded By: Meg Cutts

Motion: Amend to direct staff to work with Germantown businesses and Washington County to solicit more donations to cover the agreement costs

Motioned By: David Baum

Seconded By: Meg Cutts

Yes: Meg Cutts, Jolene Pieper, David Baum

No: None

Abstain: None

Motion to Amend Carried by Voice Vote (Yes 3, No 0, Abstained 0)

Yes: Meg Cutts, David Baum

No: Jolene Pieper

Abstain: None

Motion as Amended Carried by Voice Vote (Yes 2, No 1, Abstained 0)

- J. An Ordinance to Amend Section 9.01 of the Germantown Municipal Code Related to Offenses Against State Laws Subject to Forfeiture (ACTION)

Motion: Approve as presented

Motioned By: David Baum

Seconded By: Jolene Pieper

Yes: Meg Cutts, Jolene Pieper, David Baum

No: None

Abstain: None

Motion Carried by Voice Vote (Yes 3, No 0, Abstained 0)

- K. Discussion on County Proposal for a County-wide EMS System (DISCUSSION)

Village Administrator Kreklow and Fire Chief Delain led discussion on this item.

VIII. NEXT MEETING DATE:

IX. ADJOURNMENT:

Chairperson Trustee Cutts adjourned the meeting at 7:05 PM.

The background of the entire page is a stylized, high-contrast black and white image of the American flag. The stars are represented as white shapes on a black field, and the stripes are solid black and white bands.

**Germantown Police
★ Department**

October 2025 Monthly Report

**Prepared by:
Chief Patrick Merten**



Monthly Activity Overview Report

Printed On: 11/24/25 12:39

For Reporting Period: **10/01/2025 - 10/31/2025**

Patrol Area: **NULL,CN,CS,R,S**

NOTE: This report cannot be run based on individual officer - it is based on unique Incident. This report is for specific overview purposes & counts. For individual Officer activities, please refer to Officer Activity Count reports.

Calls

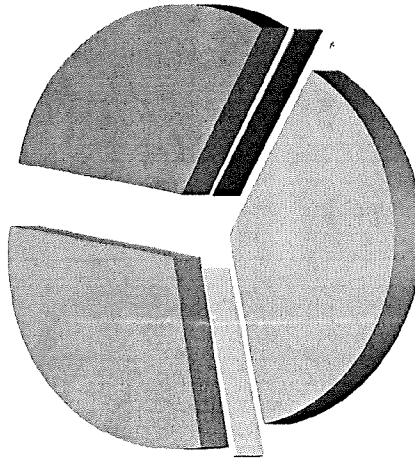

Officer Initiated 38.31%
 Other 0.57%
 Phone 30.41%
 Phone - Cell/Landline etc 30.41%
 Walk In 0.15%
 Walk-In 0.15%

Reports

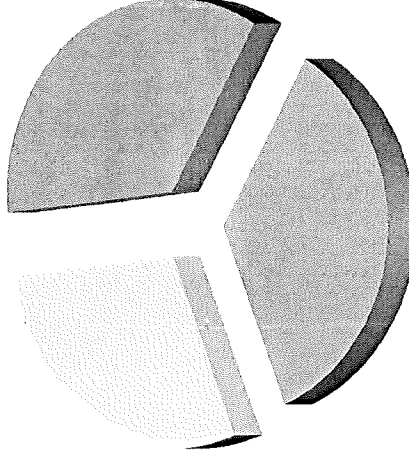

Incident 35.60%
 Property 29.32%
 Supplemental 35.08%

Reports are selected based upon Dttm report is written and selected if Dttm falls within date range above-specified.

	0001	0800	1601	Total
Officer Initiated	517	698	614	1,829
Other	362	322	325	1,009
Phone	0	14	1	15
Phone - Cell/Landline etc	154	360	287	801
Walk In	1	2	1	4
Walk-In	1	2	1	4
Hours	0800	1600	2400	
	517	698	614	

	0001	0800	1601	Total
Incident	101	156	125	382
Property	40	46	50	136
Supplemental	33	45	34	112
	28	65	41	134
Hours	0800	1600	2400	
	101	156	125	



Monthly Activity Overview Report

Printed On: 11/24/25 12:39

For Reporting Period: 10/01/2025 - 10/31/2025

Patrol Area: NULL,CN,CS,R,S

Arrests

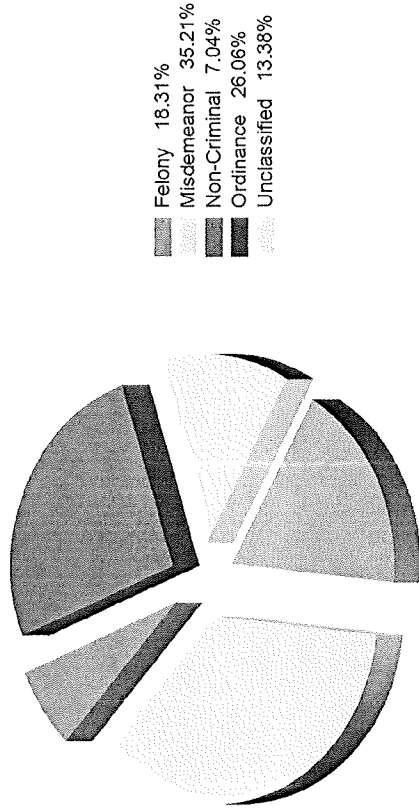

Arrests are selected based upon the charge type. Therefore if an arrest was made wherein three charges with different types are noted, the arrest will count under Each charge type.

Arrests	0001		0800		1601		Total
	0800	Hours	0800	Hours	1600	Hours	
Felony	55	8	12	6	51	36	
Misdemeanor	22	19	9	9	50	50	
Non-Criminal	5	2	3	3	10	10	
Ordinance	13	13	11	11	37	37	
Unclassified	7	5	7	7	19	19	
Total	102	55	51	36	142	142	

Citations

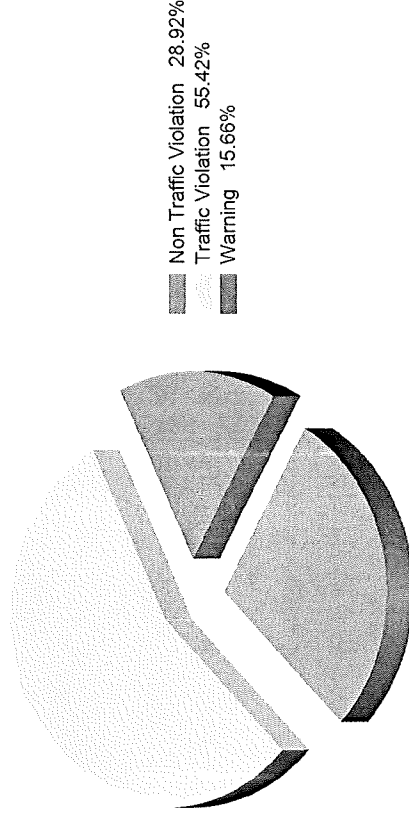

Citations are counted by Citation Type alone.

Citations	0001		0800		1601		Total
	0800	Hours	0800	Hours	1600	Hours	
Non Traffic Violation	9	7	20	16	27	20	
Traffic Violation	6	4	20	16	46	46	
Warning	12	4	6	4	12	12	
Total	35	27	46	46	82	82	



Monthly Activity Overview Report

Printed On: 11/24/25 12:39

For Reporting Period: **10/01/2025 - 10/31/2025**

Patrol Area: **NULL,CN,CS,R,S**

Field Interview Stops

No Data Available

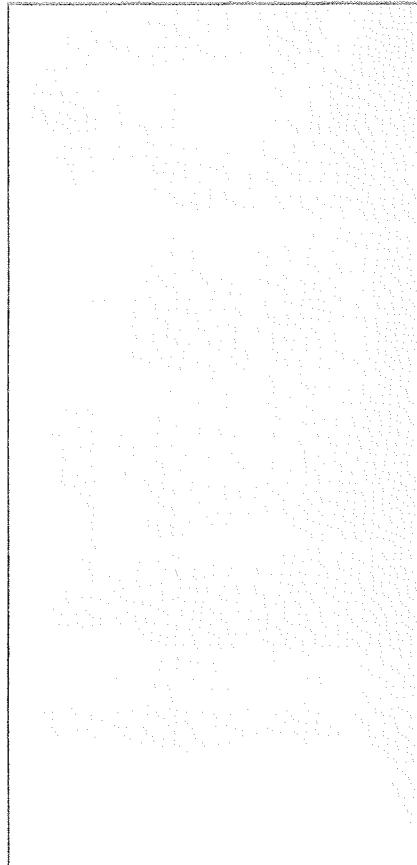

Crash

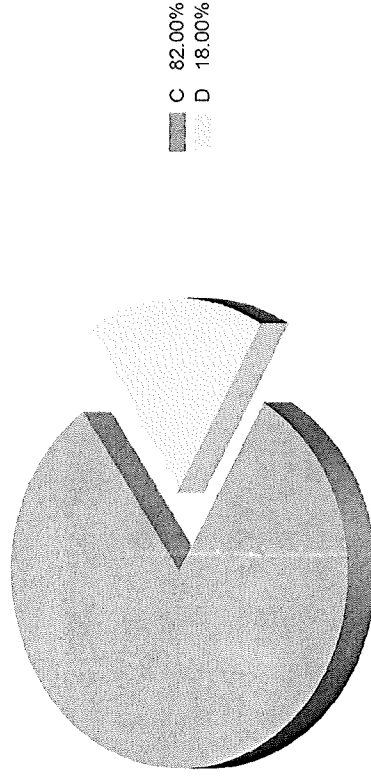

Field Interview Stops are counted by reason for stop.

Total	0
-------	---

Crashes are counted by Crash type alone.

Crash Type	0001 Hours	0800 Hours	1601 Hours	1600 Hours	2400 Hours	Total
C	16	10	17	15	16	50
D	6	6	2	2	1	9



Monthly Case Overview Report

Printed On: 11/24/25 12:41

Reporting Period: 10/01/2025 - 10/31/2025

Village of Germantown - 1182

	Total	Total
	Total	198
Accident-Car Kill Deer		8
Accident-Traffic-Hit and Run		5
Accident-Traffic-PDO		26
Accident-Traffic-Personal Injury		5
Administrative		22
Animal Bite - Dog		1
Animal Complaint - Animal Cruelty		1
Assist Other Law Enforcement Agency		4
Bail Jumping - Personal Recognizance		2
Burglary		3
Carrying a Concealed Weapon		1
Child Abuse - Simple Assault		1
Cocaine - Possession		2
Criminal Damage to Property		2
Criminal Damage to Property - Business		1
Criminal Damage to Property - Public		2
Dangerous Drugs - All Other		5
DC/Disorderly Conduct		6
DC/Disorderly Conduct - Fighting		2
Death Investigation		4
Disorderly Conduct		1
Driving/Operating Under the Influence - Alcohol		6
Drugs		1
Extortion - Threaten to Damage Property		1
Fire Investigation		1
Fire-All Other		1
Fraud - By Wire		1
Fraud - Illegal Use of a Credit Card		1
Fraud - Impersonate		3
Fraud - Swindle		1
Hallucinogen - Possession		1
Harassing Communication		1
Health or Safety		4
Informational/All Other		3
Intimidation (Including Stalking)		1
K9 Drugs		1
Larceny (Theft)		3
Lost or Found Property		4
Marijuana - Possession		10



Monthly Case Overview Report

Printed On: 11/24/25 12:41

Reporting Period: 10/01/2025 - 10/31/2025

Missing/Lost Person	2
Morals/Decency Crimes	1
Narcotic Equipment (Paraphernalia) - Possession	2
Obscene Material - Possession	1
Opening Sealed Communications	1
Prisoner Escort-Security	1
Public Relations	1
Recovered Property	4
Sex Offender Registration Violation	1
Theft - All Others <\$50	1
Theft - All Others >=\$200	3
Theft - From Auto \$50-\$199	1
Theft - Retail <\$50	3
Traffic Offense	13
Traffic Stop	4
Trespassing	1
Truancy	5
Warrant Pickup - Local Agency	1
Warrant Pickup - Probation & Parole Hold	3
Welfare Check	1



Citations by Statutes

Printed On: 11/24/25 12:43

Village of Germantown

Reporting Period: 10/01/2025 - 10/31/2025

This report contains all citations.

	Total	Non Traffic Violation	Traffic Violation	Warning
341.04(1) - Non-Registration of Vehicle	4	0	0	4
343.05(3)(a) - Operate w/o Valid License	12	0	12	0
343.44(1)(a) - Operating While Suspended	10	0	10	0
343.44(1)(b) - Operate Motor Vehicle While Revoked	1	0	0	1
343.44(1)(b) - Operating While Revoked	4	0	4	0
344.62(1) - Operate Motor Vehicle w/o Insurance	1	0	1	0
346.04(2) - Failure to Obey Traffic Officer/signal	1	0	1	0
346.04(3) - Flee/Elude Officer	1	0	1	0
346.08 - Unsafe passing on right	1	0	1	0
346.13(1) - Unsafe Lane Deviation	1	0	1	0
346.18(2) - FYR - Making Left Turn	1	0	1	0
346.37(1)(c)1 - Violate Red Traffic Signal	1	0	1	0
346.46(1) - Fail Stop At Stop Sign	3	0	0	3
346.48(1) - Fail Stop - Unload School Bus	1	0	1	0
346.57(2) - Failure to Keep Vehicle Under Control	2	0	1	1
346.57(4)(e) - Speeding on City Highway (20-24 MPH)	1	0	1	0
346.57(4)(gm)2 - Speeding on Freeway (25-29 MPH)	1	0	1	0
346.57(4)(gm)2 - Speeding on Freeway (35+ MPH)	2	0	2	0
346.57(5) - Exceed Speed Zones/Post Limits	5	0	4	1
346.63(1)(a) - OAWI Alcohol - Municipal	5	0	5	0
346.63(1)(b) - Operating with PAC .15 or >	3	0	3	0
346.63(2)(a)1 - Cause Injury/OWI - Drugs	1	0	1	0
346.69 - Hit and Run Prop	1	0	1	0
346.70(1) - Failure to Notify Police of Accident (Occupant)	1	0	1	0
347.14(1) - Operate Vehicle w/o Stopping	1	0	0	1
347.413(1) - IID Tampering/Fail to Install/Violate Court Order	1	0	1	0
9.01(115) - 3390901309	1	1	0	0
9.01(63)B - 3390901308	3	3	0	0
9.04(1) - 3390901267	3	3	0	0
9.045(3) - 3390900253	2	2	0	0
9.045(3) - Forgery - 1st	1	1	0	0
9.047(1) - 3390901074	1	1	0	0
9.047(1) - 3390901077	3	3	0	0
9.047(1) - 3390901272	1	1	0	0
9.075 - 3390901086	1	1	0	0
9.16(1) - 3390900244	1	1	0	0



Citations by Statutes

Printed On: 11/24/25 12:43

This report contains all citations.

	Total	Non Traffic Violation	Traffic Violation	Warning
940.25(1)(a) - Injury by Intoxicated Use of a Vehicle	1	0	1	0
GV9.01(54) - Theft of Movable Property	1	1	0	0
GV9.01(82) - DISORDERLY CONDUCT	4	4	0	0
GV9.04(1) - 961.41(3g)(e)MARIJUANA POSSESSION PROHIBITED	2	2	0	0
TR305.32(4)(b)2 - Vent/Side Window Excessive Tinting	6	0	4	2
TR305.32(6) - Rear Side Window Excessive Tinting	1	0	0	1
Total	98	24	60	14

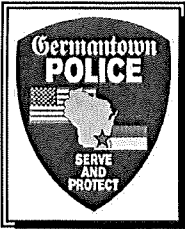

Village of Germantown Police

| , | Phone: () -

Monthly Calls for Service

Monday, November 24, 2025

12:48:39 pm

** For official use only **

Column1: 10/01/25 - 10/31/25

Column2: 10/01/24 - 10/31/24

Village of Germantown

	2020	2019	%Change
1046 - Disabled Vehicle	33	22	50.00%
ABAN - Abandoned Vehicle	0	3	-
ACAL - Accident-All Other	3	0	-
ACHR - Accident-Traffic-Hit and Run	8	9	-11.11%
ACPD - Accident-Traffic-Property Damage Only	32	30	6.67%
ACPI - Accident-Traffic-Personal Injury	6	10	-40.00%
ACVD - Accident-Traffic-Vehicle in Ditch	2	1	100.00%
ALMA - Alarm-All	33	25	32.00%
ALMF - Fire-Alarm	12	8	50.00%
ALMM - Alarm-Carbon Monoxide	2	3	-33.33%
ALPR - Automatic License Plate Recognition	1	2	-50.00%
AMLB - Animal Bite	1	1	0.00%
AMLC - Animal Complaint (Excludes bites)	30	18	66.67%
ASLO - Assist-Lockout	15	13	15.38%
ASOT - Assistance-All Others	57	37	54.05%
ASPD - Assistance-Other Law Enforcement Ager	32	30	6.67%
BURG - Burglary	2	1	100.00%
CHLD - Child Abuse	2	2	0.00%
CIVM - Civil Matter	7	14	-50.00%
CKD - Accident-Traffic-Car Kill Deer	11	22	-50.00%
CP - Civil Process	4	1	300.00%
CW - Contract Work	0	1	-
DARE - Teaching DARE Class within the school	0	4	-
DC - Disorderly Conduct	23	40	-42.50%
DINV - Death Investigation	4	1	300.00%
DOM - Domestic	3	1	200.00%
DRON - Drone	4	3	33.33%
DRUG - Drugs-Violation-Controlled Substance	7	4	75.00%
E911 - E911 Abandoned/False Calls	86	80	7.50%
ESCT - Escort/Bank Run, etc	0	1	-
ESPR - Prisoner Escort-Security	2	0	-
EXTO - Extortion	1	0	-
FAMT - Family Trouble Excludes Domestic	3	5	-40.00%
FING - Fingerprinting	9	5	80.00%

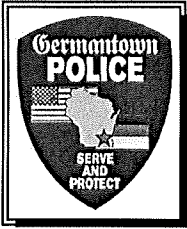

Village of Germantown Police

| , | Phone: () -

Monthly Calls for Service

Monday, November 24, 2025
12:48:39 pm

** For official use only **

Column1: 10/01/25 - 10/31/25

Column2: 10/01/24 - 10/31/24

FIRM - Fire-Mabas call	1	0	-
FIRO - Fire-All Other	10	14	-28.57%
FRAU - Fraudulent Activities	8	10	-20.00%
FU - Follow up	0	3	-
HARA - Harassment (Includes phone calls)	9	12	-25.00%
HAZ - Hazardous Conditions-Road Hazards	28	33	-15.15%
IDEN - Identity Theft	1	1	0.00%
INF - Informational report	3	15	-80.00%
JUV - Juvenile-Status (Includes Runaway)	8	3	166.67%
K9DRUG - K9 Drug Investigations	16	0	-
K9OTHR - K9 Other	6	0	-
K9SRCH - K9 Searches	1	0	-
LIT - Littering	1	2	-50.00%
LOST - Lost Property	1	1	0.00%
MNTL - Mental-Walkaway/Incapacited/Etc	4	3	33.33%
MUNI - Municipal Ordinance Investigation	3	10	-70.00%
MVT - Motor Vehicle Theft	1	1	0.00%
NOISE - Noise Complaints	7	0	-
OPEN - Open Door	1	6	-83.33%
PARK - Parking Violation	3	12	-75.00%
PKCK - Park Check	0	225	-
PR - Public Relations	195	163	19.63%
PROP - Property Check	163	228	-28.51%
RCOV - Recovered Property	10	8	25.00%
REPO - Repossessions	9	0	-
RESC - Ambulance Request	152	122	24.59%
SBUS - School Bus Violation	0	1	-
SCHO - School Grounds Visit	33	84	-60.71%
SEXA - Sexual Assault	1	1	0.00%
SEXO - Sex Offense	1	2	-50.00%
SOLICIT - Soliciting	0	4	-
SORC - Sexual Offender Registry Check	1	0	-
SUSP - Suspicious Person/Vehicle/Situation	25	56	-55.36%
SWAT - SWAT	0	2	-
TE - Traffic Enforcement	52	23	126.09%
TG - Training	1	4	-75.00%
THFT - Larceny (Theft)	19	39	-51.28%

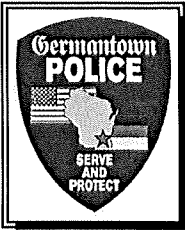

Village of Germantown Police

| , | Phone: () -

Monthly Calls for Service

Monday, November 24, 2025

12:48:39 pm

** For official use only **

Column1: 10/01/25 - 10/31/25

Column2: 10/01/24 - 10/31/24

TKIN - Truck Inspection	1	0	-
TOBC - Tobacco Violations (All).	0	4	-
TR - Traffic Request	2	22	-90.91%
TRAF - Traffic Stop	469	279	68.10%
TRES - Trespassing/Prowler	7	2	250.00%
TRO - Restraining Order/Injunction Violation	1	3	-66.67%
TRUA - Truancy	5	2	150.00%
TVRN - Tavern Check	4	11	-63.64%
VAND - Vandalism-Damage to Property	6	5	20.00%
VEHT - Vehicle Traffic	63	42	50.00%
WEAP - Weapons Offense	3	5	-40.00%
WELF - Welfare Check	45	22	104.55%
WRNT - Warrant Service/Attempt	14	8	75.00%
Total	1,829	1,890	



Arrests by Statute Report

Printed On: 11/24/25 12:49

Reporting Period: 10/01/25 - 10/31/25

This report contains all arrest charges.

	Total	Felony	Misdemeanor	Non-Criminal	Ordinance	Unclassified
302.095(2)(b) - Possession of any article or thing contrary to rules or regulations	1	1				
341.15(1) - Fail/Display Vehicle License Plates	1			1		
343.05(3)(a) - Operating Without a License - 1st Offense	1				1	
343.05(3)(a) - Operating Without a License - 2nd Offense within 3 Years	9		9			
343.305(9)(a) - Refuse/Breathalyzer Test After Arrest	1			1		
343.44(1)(b) - Operating While Revoked	4		4			
346.04(3) - Veh. Operator Flee/Elude Officer	1	1				
346.63(1)(a) - Operating While Intoxicated - 1st Offense	4				4	
346.63(1)(a) - Operating While Intoxicated - 3rd Offense	1		1			
346.63(1)(b) - Operating with PAC .08 or >	1			1		
346.63(1)(b) - Operating With Prohibited Alcohol Concentration - 1st Offense, PAC >=.08,<.15	1				1	
346.63(1)(b) - Operating With Prohibited Alcohol Concentration - 1st Offense, PAC>=.15	1				1	
346.63(1)(b) - Operating With Prohibited Alcohol Concentration - 3rd Offense	1		1			
346.63(2)(a)1 - Operating While Intoxicated Causing Injury - 1st Offense, PAC < 0.15	1		1			
346.67(1) - Hit and Run-Attended Vehicle	1		1			
346.935(2) - Possess Open Intoxicants in MV - Driver	1				1	
347.413(1) - IID Tampering/Failure to Install	1		1			
450.11(9)(b) - Manufacture or Deliver Prescription Drug	1	1				
51.15(1) - Emergency Detention	1			1		
9009 - Warrant Pickup - Local Agency	1				1	
9010 - Warrant Pickup - Other Agency	1				1	
90Z4 - Warrant-Other Department Pickup	1			1		
90Z5 - Warrant - Local	2			2		
90Z6 - Warrant - Probation & Parole	3			3		
940.25(1)(a) - Injury by Intox. Use/Vehicle	1	1				
940.25(1)(b) - Injury by Use of Vehicle with PAC	1	1				
941.23(2) - Carrying Concealed Weapon	1		1			
941.29(1m)(a) - Felon in possession of a Firearm - Convicted of a felony in this state.	1	1				
941.30(2) - 2nd-Degree Recklessly Endangering Safety	1	1				
941.30(2) - Second Degree Recklessly Endangering Safety	1	1				
943.20(1)(a) - Theft - Misdemeanor	1		1			
943.201(2) - Unuth Use of Individual's ID or Document/Info	3	3				
943.50(1m)(b) - Retail Theft - Intentionally Take - (<=\$2,500)(UCR \$50-\$199)	1		1			
943.50(1m)(b) - Retail Theft - Intentionally Take - (<=\$2,500)(UCR <\$50)	1		1			
943.50(4)(bf) - Retail Theft more than \$500 but less than \$5,000.	1	1				
946.41(1) - Resist or Obstruct an Officer	1		1			



Arrests by Statute Report

Printed On: 11/24/25 12:49

Reporting Period: 10/01/25 - 10/31/25

This report contains all arrest charges.

	Total	Felony	Misdemeanor	Non-Criminal	Ordinance	Unclassified
946.41(1) - Resisting or Obstructing an Officer	2		2			
946.49(1)(a) - Bail Jumping-Misdemeanor	5		5			
946.49(1)(b) - Bail Jumping-Felony	5	5				
947.01(1) - Disorderly Conduct	12		7		5	
948.093 - Underage Sexual Activity - Sexual Contact with Child Age 15, Actor Under Age 19	1		1			
961.41(1)(b) - Manufacture/Deliver Non-Narcotics	1	1				
961.41(1)(cm)3 - Manuf/Deliver Cocaine (>15-40g)	1	1				
961.41(1)(h)1 - Manufacture/Deliver Marijuana/THC (<=200 grams)	1	1				
961.41(1m) - Possess w/Intent/Deliver Narcotics	1	1				
961.41(3g)(am) - Possession of Narcotic Drugs	2	2				
961.41(3g)(c) - Possession of Cocaine	1		1			
961.41(3g)(c) - Possession of Cocaine (2nd and subsequent)	1	1				
961.41(3g)(d) - Possession of Controlled Substance (Certain Hallucinogenic and Stimulant Drugs)	1		1			
961.41(3g)(e) - Possession of Marijuana/THC	4		4			
961.41(3g)(e) - Possession of THC (Tetrahydrocannabinols) - (2nd and subsequent)	1	1				
961.41(3g)(g) - Possess Methamphetamine	1	1				
961.573(1) - Possess Drug Paraphernalia	6		6			
968.075 - Domestic Abuse Incident	3					3
968.075(1)(a) - Domestic Abuse	1					1
ADMIN - Mental Health/Cri - Mental Health/Crisis Safety Plan	1					1
ADMIN - Overdose - Overdose	1					1
ADMIN - Warrant - Warrant	13					13
GV9.01(115) - POSSESSION OF MARIJUANA	3				3	
GV9.01(54) - Theft of Movable Property	1				1	
GV9.01(63)b - SHOPLIFTING - CONCEAL MERCHANDISE	3				3	
GV9.04(1) - 961.41(3g)(e)MARIJUANA POSSESSION PROHIBITED	6				6	
GV9.045(3) - 961.573(1) POSSESSION OF DRUG PARAPHERNALIA	2				2	
GV9.045(3) - 961.573(1) POSSESSION OF DRUG PARAPHERNALIA-2ND OFF	1				1	
GV9.047(1) - 118.163(1)(b) HABITUAL TRUANCY (ADULT)	1				1	
GV9.047(1) - 118.163(1)(b) HABITUAL TRUANCY (JUVENILE)	3				3	
GV9.047(1) - 118.163(1)(d) TRUANCY (JUVENILE)	1				1	
GV9.075 - Student Use/Possession of Comm Device	1				1	
Total	142	26	50	10	37	19



Call Simple Lists

Printed On: 11/24/25 12:57

Village of Germentown

Call#	Reported Date	CAD CFS	Location	Common Name	Disp	Unit#	Officer(s)
25-017605	10/31/25 19:55	Public Relations	N112W18741 Mequon Rd;GV	Kwik Trip GV	NRPT	735	JRS097
25-017584	10/31/25 11:04	Public Relations	N112W16222 Mequon Rd;GV	Dollar Tree-Mequon Rd.	NRPT	732	ARB093
25-017583	10/31/25 10:58	Public Relations	N128W21760 Holy Hill Rd,A;GV	Holy Hill Shell Glory Realm Cafe	NRPT	750	AML9130
25-017582	10/31/25 10:58	Public Relations	N112W18741 Mequon Rd;GV	Kwik Trip GV	NRPT	737	DJP083
25-017575	10/31/25 07:44	Public Relations	N108W14290 Bel Aire La;GV	Bethlehem Lutheran Church	NRPT	733	MMO119
25-017573	10/31/25 07:17	Public Relations	W180N11501 River La;GV	Germentown High School	NRPT	737	DJP083
25-017572	10/31/25 07:07	Public Relations	N118W15860 Williams Dr;GV	Kennedy Middle School	NRPT	750	AML9130
25-017549	10/30/25 19:42	Public Relations	N112W18741 Mequon Rd;GV	Kwik Trip GV	NRPT	735	JRS097
25-017519	10/30/25 10:35	Public Relations	W154N11492 Fond Du Lac Av;GV	Macarthur Elementary School	NRPT	730	TEO138
25-017511	10/30/25 07:41	Public Relations	N108W14290 Bel Aire La;GV	Bethlehem Lutheran Church	NRPT	737	DJP083
25-017509	10/30/25 07:32	Public Relations	N118W15860 Williams Dr;GV	Kennedy Middle School	NRPT	733	MMO119
25-017505	10/30/25 07:05	Public Relations	W180N11501 River La;GV	Germentown High School	NRPT	750	AML9130
25-017496	10/30/25 02:15	Public Relations	N112W18741 Mequon Rd;GV	Kwik Trip GV	NRPT	743	JAR0107
25-017490	10/29/25 20:50	Public Relations	N112W18741 Mequon Rd;GV	Kwik Trip GV	NRPT	735	JRS097
25-017453	10/29/25 08:33	Public Relations	W154N11492 Fond Du Lac Av;GV	Macarthur Elementary School	NRPT	736	JLS084
25-017449	10/29/25 07:26	Public Relations	N108W14290 Bel Aire La;GV	Bethlehem Lutheran Church	NRPT	750	AML9130
25-017448	10/29/25 07:07	Public Relations	W180N11501 River La;GV	Germentown High School	NRPT	733	MMO119
25-017440	10/29/25 04:19	Public Relations	N96W21962 County Line Rd;GV	BP GV (Amy Belle)	NRPT	738	NWK1173
25-017405	10/28/25 09:41	Public Relations	W154N11492 Fond Du Lac Av;GV	Macarthur Elementary School	NRPT	730	TEO138
25-017401	10/28/25 08:48	Public Relations	W154N11492 Fond Du Lac Av;GV	Macarthur Elementary School	NRPT	750	AML9130
25-017397	10/28/25 08:07	Public Relations	W159N9939 Butternut Rd;GV	County Line School	NRPT	733	MMO119
25-017394	10/28/25 07:17	Public Relations	N108W14290 Bel Aire La;GV	Bethlehem Lutheran Church	NRPT	733	MMO119
25-017392	10/28/25 07:05	Public Relations	N118W15860 Williams Dr;GV	Kennedy Middle School	NRPT	750	AML9130
25-017388	10/28/25 06:39	Public Relations	W180N11501 River La;GV	Germentown High School	NRPT	736	JLS084
25-017347	10/27/25 08:00	Public Relations	N128W21760 Holy Hill Rd,A;GV	Holy Hill Shell GV	NRPT	737	DJP083



Call Simple Lists

Printed On: 11/24/25 12:57

Call#	Reported Date	CAD CFS	Location	Common Name	Disp	Unit#	Officer(s)
25-017344	10/27/25 07:25	Public Relations	N118W15860 Williams Dr;GV	Kennedy Middle School	NRPT	737	DJP083
25-017342	10/27/25 07:00	Public Relations	N112W18741 Mequon Rd;GV	Kwik Trip GV	NRPT	747	BPD9058
25-017337	10/27/25 02:12	Public Relations	N112W18741 Mequon Rd;GV	Kwik Trip GV	NRPT	744	ALC9032
25-017315	10/26/25 14:58	Public Relations	N112W18741 Mequon Rd;GV	Kwik Trip GV	NRPT	751	ARA1061 KMK9135
25-017314	10/26/25 13:30	Public Relations	N112W16510 Mequon Rd;2;GV	Jersey Mike's Subs	NRPT	747	BPD9058
25-017311	10/26/25 12:48	Public Relations	W172N11183 Division Rd;GV	Faith Lutheran Church	NRPT	737	DJP083
25-017307	10/26/25 12:34	Public Relations	W172N11183 Division Rd;GV	Faith Lutheran Church	NRPT	747	BPD9058
25-017304	10/26/25 11:51	Public Relations	N112W16040 Mequon Rd;GV	Roberts Frozen Custard	NRPT	737	DJP083
25-017286	10/26/25 06:38	Public Relations	N112W16510 Mequon Rd;A;GV	Starbucks VGTN - Mequon Rd.	NRPT	747	BPD9058
25-017282	10/26/25 05:24	Public Relations	N112W18741 Mequon Rd;GV	Kwik Trip GV	NRPT	742	AWD0105
25-017245	10/25/25 18:31	Public Relations	N96W17698 County Line Rd;GV	Panda Express GV	NRPT	747	BPD9058
25-017242	10/25/25 17:45	Public Relations	N112W18741 Mequon Rd;GV	Kwik Trip GV	NRPT	735	JRS097
25-017235	10/25/25 12:35	Public Relations	N96W17698 County Line Rd;GV	Panda Express GV	NRPT	733	MMO119
25-017206	10/24/25 23:09	Public Relations	N112W18741 Mequon Rd;GV	Kwik Trip GV	NRPT	743	JAR0107
25-017199	10/24/25 19:45	Public Relations	W180N11501 River La;GV	Germantown High School	NRPT	749	JMH9110
25-017194	10/24/25 18:43	Public Relations	N112W18741 Mequon Rd;GV	Kwik Trip GV	NRPT	735	JRS097
25-017193	10/24/25 18:23	Public Relations	W180N11501 River La;GV	Germantown High School	NRPT	730	TEO138
25-017192	10/24/25 18:20	Public Relations	W180N11501 River La;GV	Germantown High School	NRPT	720	SDJ101
25-017185	10/24/25 15:57	Public Relations	N112W18741 Mequon Rd;GV	Kwik Trip GV	NRPT	747	BPD9058
25-017184	10/24/25 15:51	Public Relations	W156N11482 Pilgrim Rd;GV	Jenna Furs Dog Grooming	NRPT	735	JRS097
25-017182	10/24/25 15:35	Public Relations	N112W16268 Mequon Rd;GV	Jimmy Johns Vgtn	NRPT	749	JMH9110
25-017176	10/24/25 14:17	Public Relations	W159N9939 Butternut Rd;GV	County Line School	NRPT	730	TEO138
25-017169	10/24/25 10:39	Public Relations	N128W21760 Holy Hill Rd;A;GV	Holy Hill Shell GV	NRPT	737	DJP083
25-017168	10/24/25 10:14	Public Relations	N96W21962 County Line Rd;GV	BP GV (Amy Belle)	NRPT	733	MMO119
25-017162	10/24/25 08:40	Public Relations	W154N11492 Fond Du Lac Av;GV	Macarthur Elementary School	NRPT	733	MMO119
25-017157	10/24/25 08:01	Public Relations	W159N9939 Butternut Rd;GV	County Line School	NRPT	750	AML9130



Call Simple Lists

Printed On: 11/24/25 12:57

Call#	Reported Date	CAD CFS	Location	Common Name	Disp	Unit#	Officer(s)
25-017155	10/24/25 07:24	Public Relations	W204N11968 Goldendale Rd;GV	St. Boniface School St Boniface Church	NRPT	733	MMO119
25-017154	10/24/25 07:13	Public Relations	N118W15860 Williams Dr;GV	Kennedy Middle School	NRPT	733	MMO119
25-017153	10/24/25 07:03	Public Relations	W180N11501 River La;GV	Germantown High School	NRPT	733	MMO119
25-017152	10/24/25 07:02	Public Relations	N108W14290 Bel Aire La;GV	Bethlehem Lutheran Church	NRPT	750	AML9130
25-017190	10/24/25 00:00	Public Relations	W180N11501 River La;GV	Germantown High School	NRPT	730	TEO138
25-017122	10/23/25 20:33	Public Relations	W187N12793 Fond Du Lac Av;GV	Stags Tavern	NRPT	741	DPK0106
25-017119	10/23/25 17:36	Public Relations	N112W18741 Mequon Rd;GV	Kwik Trip GV	NRPT	735	JRS097
25-017101	10/23/25 10:27	Public Relations	W154N11492 Fond Du Lac Av;GV	Macarthur Elementary School	NRPT	730	TEO138
25-017093	10/23/25 07:58	Public Relations	W204N11968 Goldendale Rd;GV	St. Boniface School St Boniface Church	NRPT	736	JLS084
25-017091	10/23/25 07:46	Public Relations	N112W18741 Mequon Rd;GV	Kwik Trip GV	NRPT	736	JLS084
25-017088	10/23/25 06:54	Public Relations	W180N11501 River La;GV	Germantown High School	NRPT	736	JLS084
25-016922	10/21/25 14:55	Public Relations	N112W16510 Mequon Rd,2;GV	Jersey Mike's Subs	NRPT	730	TEO138
25-016911	10/21/25 09:45	Public Relations	W154N11492 Fond Du Lac Av;GV	Macarthur Elementary School	NRPT	730	TEO138
25-016906	10/21/25 08:34	Public Relations	W154N11492 Fond Du Lac Av;GV	Macarthur Elementary School	NRPT	736	JLS084
25-016903	10/21/25 07:17	Public Relations	W180N11501 River La;GV	Germantown High School	NRPT	742	AWD0105
25-016902	10/21/25 07:15	Public Relations	N118W15860 Williams Dr;GV	Kennedy Middle School	NRPT	736	JLS084
25-016892	10/21/25 01:51	Public Relations	N112W18741 Mequon Rd;GV	Kwik Trip GV	NRPT	746	TJN9088
25-016887	10/21/25 00:50	Public Relations	N101W17667 Misty Morning Way;GV		NRPT	746	TJN9088
25-016886	10/21/25 00:40	Public Relations	N112W18741 Mequon Rd;GV	Kwik Trip GV	NRPT	715	JSC079
25-016871	10/20/25 18:34	Public Relations	N112W15800 Mequon Rd,STORE;GV	Sendiks Vgtn	NRPT	747	BPD9058
25-016858	10/20/25 12:44	Public Relations	N112W15800 Mequon Rd,STORE;GV	Sendiks Vgtn Auto Zone	NRPT	742	AWD0105
25-016845	10/20/25 07:26	Public Relations	W180N11501 River La;GV	Germantown High School	NRPT	751	JLS084
25-016840	10/20/25 06:44	Public Relations	N112W18741 Mequon Rd;GV	Kwik Trip GV	NRPT	751	JLS084
25-016838	10/20/25 02:49	Public Relations	N112W18741 Mequon Rd;GV	Kwik Trip GV	NRPT	744	ALC9032



Call Simple Lists

Printed On: 11/24/25 12:57

Call#	Reported Date	CAD CFS	Location	Common Name	Disp	Unit#	Officer(s)
25-016811	10/19/25 15:49	Public Relations	N112W18741 Mequon Rd;GV	Kwik Trip GV	NRPT	741	DPK0106
25-016801	10/19/25 12:04	Public Relations	W156N10041 Pilgrim Rd;GV	Cross Way Church	NRPT	750	AML9130
25-016800	10/19/25 12:01	Public Relations	N112W18741 Mequon Rd;GV	Kwik Trip GV	NRPT	747	BPD9058
25-016796	10/19/25 08:26	Public Relations	W164N11325 Squire Dr;GV	Life Church	NRPT	751	KMK9135 MMO119
25-016794	10/19/25 08:10	Public Relations	N112W18741 Mequon Rd;GV	Kwik Trip GV	NRPT	751	KMK9135 MMO119
25-016745	10/18/25 11:52	Public Relations	W164N11233 Squire Dr;GV	Speedway GV	NRPT	751	KMK9135 MMO119
25-016743	10/18/25 11:40	Public Relations	N112W17001 Mequon Rd;GV	Village of Germantown Parks and Recreation	NRPT	747	BPD9058
25-016734	10/18/25 07:44	Public Relations	N112W18741 Mequon Rd;GV	Kwik Trip GV	NRPT	750	AML9130
25-016733	10/18/25 06:45	Public Relations	N112W16510 Mequon Rd;A;GV	Starbucks VGTN - Mequon Rd.	NRPT	747	BPD9058
25-016720	10/17/25 23:30	Public Relations	N112W18741 Mequon Rd;GV	Kwik Trip GV	NRPT	738	NWK1173
25-016710	10/17/25 16:00	Public Relations	N112W18741 Mequon Rd;GV	Kwik Trip GV	NRPT	745	ALP9041
25-016699	10/17/25 12:35	Public Relations	N112W18741 Mequon Rd;GV	Kwik Trip GV	NRPT	733	MMO119
25-016690	10/17/25 08:40	Public Relations	W154N11492 Fond Du Lac Av;GV	Macarthur Elementary School	NRPT	736	JLS084
25-016687	10/17/25 07:38	Public Relations	W159N9939 Butternut Rd;GV	County Line School	NRPT	733	MMO119
25-016686	10/17/25 07:29	Public Relations	N118W15860 Williams Dr;GV	Kennedy Middle School	NRPT	736	JLS084
25-016685	10/17/25 07:28	Public Relations	N108W14290 Bel Aire La;GV	Bethlehem Lutheran Church	NRPT	733	MMO119
25-016682	10/17/25 07:18	Public Relations	N112W16510 Mequon Rd;A;GV	Starbucks VGTN - Mequon Rd.	NRPT	736	JLS084
25-016675	10/17/25 03:33	Public Relations	W178N9653 Riversbend La;GV	Speedway GV	NRPT	748	TSW9112
25-016672	10/17/25 02:16	Public Relations	W147N10681 Heritage Pkwy;GV		NRPT	738	NWK1173
25-016649	10/16/25 15:19	Public Relations	3294 Willow Creek Rd;RV	Amy Belle School	NRPT	730	TEO138
25-016637	10/16/25 10:35	Public Relations	W154N11492 Fond Du Lac Av;GV	Macarthur Elementary School	NRPT	730	TEO138
25-016621	10/16/25 00:39	Public Relations	N112W18741 Mequon Rd;GV	Kwik Trip GV	NRPT	738	NWK1173
25-016605	10/15/25 16:02	Public Relations	N112W16510 Mequon Rd;A;GV	Starbucks VGTN - Mequon Rd.	NRPT	745	ALP9041
25-016593	10/15/25 10:57	Public Relations	N112W18741 Mequon Rd;GV	Kwik Trip GV	NRPT	751	DJP083 KMK9135
25-016583	10/15/25 08:03	Public Relations	W159N9939 Butternut Rd;GV	County Line School	NRPT	736	JLS084
25-016581	10/15/25 07:32	Public Relations	N108W14290 Bel Aire La;GV	Bethlehem Lutheran Church	NRPT	736	JLS084



Call Simple Lists

Printed On: 11/24/25 12:57

Call#	Reported Date	CAD CFS	Location	Common Name	Disp	Unit#	Officer(s)
25-016551	10/14/25 14:14	Public Relations	W156N1150 Pilgrim Rd;GV	BMO Harris Bank - Germantown	NRPT	732	ARB093
25-016550	10/14/25 14:14	Public Relations	W156N9650 Pilgrim Rd;GV	Citgo Clark Oil GV	NRPT	732	ARB093
25-016539	10/14/25 10:00	Public Relations	N120W19809 Freistadt Rd;GV	Homestead Hollow County Park	NRPT	751	DJP083 KMK9135
25-016535	10/14/25 09:27	Public Relations	W154N11492 Fond Du Lac Av;GV	Macarthur Elementary School	NRPT	730	TEO138
25-016534	10/14/25 09:18	Public Relations	N128W21760 Holy Hill Rd,A;GV	Holy Hill Shell Shell GV	NRPT	751	DJP083 KMK9135
25-016533	10/14/25 09:07	Public Relations	N112W18741 Mequon Rd;GV	Kwik Trip GV	NRPT	707	JR098
25-016532	10/14/25 08:32	Public Relations	N112W16298 Mequon Rd;GV	UPS Store	NRPT	707	JR098
25-016531	10/14/25 08:32	Public Relations	W154N11492 Fond Du Lac Av;GV	Macarthur Elementary School	NRPT	736	JLS084
25-016524	10/14/25 06:55	Public Relations	N118W15860 Williams Dr;GV	Kennedy Middle School	NRPT	736	JLS084
25-016523	10/14/25 06:55	Public Relations	W180N11501 River La;GV	Germantown High School	NRPT	742	AWD0105
25-016506	10/13/25 23:00	Public Relations	N112W18741 Mequon Rd;GV	Kwik Trip GV	NRPT	743	JAR0107
25-016489	10/13/25 17:26	Public Relations	N112W16200 Mequon Rd;GV	Pick N Save	NRPT	707	JR098
25-016484	10/13/25 15:59	Public Relations	W160N10000 Colonial Dr;GV	Spassland Park	NRPT	741	DPK0106
25-016479	10/13/25 13:06	Public Relations	N96W17698 County Line Rd;GV	Panda Express GV	NRPT	733	MMO119
25-016476	10/13/25 09:51	Public Relations	W162N11870 Park Av;GV	Firemen's Park Firemans Park GV	NRPT	751	DJP083 KMK9135
25-016474	10/13/25 09:24	Public Relations	W140N11492 Country Aire Dr;GV	Friedenfeld Park	NRPT	751	DJP083 KMK9135
25-016473	10/13/25 08:55	Public Relations	W159N9939 Butternut Rd;GV	County Line School	NRPT	733	MMO119
25-016472	10/13/25 08:34	Public Relations	W154N11492 Fond Du Lac Av;GV	Macarthur Elementary School	NRPT	751	DJP083 KMK9135
25-016469	10/13/25 07:34	Public Relations	N108W14290 Bel Aire La;GV	Bethlehem Lutheran Church	NRPT	733	MMO119
25-016468	10/13/25 07:27	Public Relations	N118W15860 Williams Dr;GV	Kennedy Middle School	NRPT	751	DJP083 KMK9135
25-016467	10/13/25 07:16	Public Relations	W164N11233 Squire Dr;GV	Speedway GV	NRPT	751	DJP083 KMK9135
25-016466	10/13/25 07:14	Public Relations	W130N10200 Town 9 Pkwy;GV	DPW GV	NRPT	733	MMO119
25-016465	10/13/25 07:00	Public Relations	N112W16510 Mequon Rd,A;GV	Starbucks VGTN - Mequon Rd.	NRPT	733	MMO119
25-016464	10/13/25 06:55	Public Relations	W180N11501 River La;GV	Germantown High School	NRPT	750	AML9130



Call Simple Lists

Printed On: 11/24/25 12:57

Call#	Reported Date	CAD CFS	Location	Common Name	Disp	Unit#	Officer(s)
25-016453	10/13/25 00:59	Public Relations	W156N11150 Pilgrim Rd;GV	BMO Harris Bank - Germantown	NRPT	738	NWK1173
25-016450	10/12/25 23:04	Public Relations	N112W18741 Mequon Rd;GV	Kwik Trip GV	NRPT	743	JAR0107
25-016395	10/11/25 19:41	Public Relations	N102W19455 Willow Creek Way;GV	Metro Cigars Vgtn	NRPT	741	DPK0106
25-016372	10/11/25 11:52	Public Relations	N96W18200 County Line Rd;GV	Fleet Farm GV	NRPT	732	ARB093
25-016354	10/11/25 05:44	Public Relations	N112W18741 Mequon Rd;GV	Kwik Trip GV	NRPT	750	AML9130
25-016352	10/11/25 02:18	Public Relations	N112W18741 Mequon Rd;GV	Kwik Trip GV	NRPT	744	ALC9032
25-016334	10/10/25 18:43	Public Relations	N118W15860 Williams Dr;GV	Kennedy Middle School	NRPT	731	KCL088
25-016333	10/10/25 18:31	Public Relations	W180N11501 River La;GV	Germantown High School	NRPT	730	TEO138
25-016321	10/10/25 15:50	Public Relations	N112W18741 Mequon Rd;GV	Kwik Trip GV	NRPT	745	ALP9041
25-016319	10/10/25 15:45	Public Relations	W154N11492 Fond Du Lac Av;GV	Macarthur Elementary School	NRPT	730	TEO138
25-016311	10/10/25 12:51	Public Relations	N112W16040 Mequon Rd;GV	Roberts Frozen Custard	NRPT	742	AWD0105
25-016295	10/10/25 08:21	Public Relations	W159N9939 Butternut Rd;GV	County Line School	NRPT	731	KCL088
25-016293	10/10/25 08:06	Public Relations	W159N9939 Butternut Rd;GV	County Line School	NRPT	736	JLS084
25-016292	10/10/25 07:52	Public Relations	N112W18741 Mequon Rd;GV	Kwik Trip GV	NRPT	736	JLS084
25-016287	10/10/25 06:48	Public Relations	W180N11501 River La;GV	Germantown High School	NRPT	750	AML9130
25-016283	10/10/25 02:50	Public Relations	N112W18741 Mequon Rd;GV	Kwik Trip GV	NRPT	744	ALC9032
25-016279	10/10/25 01:32	Public Relations	N112W18741 Mequon Rd;GV	Kwik Trip GV	NRPT	738	NWK1173
25-016267	10/09/25 19:35	Public Relations	N112W18741 Mequon Rd;GV	Kwik Trip GV	NRPT	747	BPD9058
25-016238	10/09/25 09:20	Public Relations	N118W15860 Williams Dr;GV	Kennedy Middle School	NRPT	736	JLS084
25-016237	10/09/25 08:59	Public Relations	N112W18741 Mequon Rd;GV	Kwik Trip GV	NRPT	751	DJP083
25-016236	10/09/25 08:33	Public Relations	W154N11492 Fond Du Lac Av;GV	Macarthur Elementary School	NRPT	736	JLS084
25-016235	10/09/25 08:00	Public Relations	2900 Hy 167;RV	Kwik Trip RV	NRPT	736	JLS084
25-016228	10/09/25 02:56	Public Relations	N112W18741 Mequon Rd;GV	Kwik Trip GV	NRPT	744	ALC9032
25-016217	10/08/25 23:03	Public Relations	N112W18741 Mequon Rd;GV	Kwik Trip GV	NRPT	743	JAR0107
25-016201	10/08/25 14:55	Public Relations	N112W18741 Mequon Rd;GV	Kwik Trip GV	NRPT	707	JR098



Call Simple Lists

Printed On: 11/24/25 12:57

Call#	Reported Date	CAD CFS	Location	Common Name	Disp	Unit#	Officer(s)
25-016187	10/08/25 08:22	Public Relations	N112W18741 Mequon Rd;GV	Kwik Trip GV	NRPT	736	JLS084
25-016183	10/08/25 07:08	Public Relations	N118W15860 Williams Dr;GV	Kennedy Middle School	NRPT	751	KMK9135
25-016180	10/08/25 06:55	Public Relations	W180N11501 River La;GV	Germentown High School	NRPT	736	JLS084
25-016177	10/08/25 06:36	Public Relations	W204N11968 Goldendale Rd;GV	St. Boniface School St Boniface Church	NRPT	736	JLS084
25-016166	10/08/25 03:07	Public Relations	N112W18741 Mequon Rd;GV	Kwik Trip GV	NRPT	744	ALC9032
25-016157	10/07/25 23:18	Public Relations	N112W18741 Mequon Rd;GV	Kwik Trip GV	NRPT	743	JAR0107
25-016156	10/07/25 23:12	Public Relations	W164N11233 Squire Dr;GV	Speedway GV	NRPT	746	TJN9088
25-016151	10/07/25 19:55	Public Relations	N96W17698 County Line Rd;GV	Panda Express GV	NRPT	746	TJN9088
25-016126	10/07/25 11:51	Public Relations	N96W17698 County Line Rd;GV	Panda Express GV	NRPT	733	MMO1119
25-016113	10/07/25 07:02	Public Relations	N118W15860 Williams Dr;GV	Kennedy Middle School	NRPT	750	AML9130
25-016112	10/07/25 06:48	Public Relations	W180N11501 River La;GV	Germentown High School	NRPT	751	DJP083
25-016096	10/06/25 18:12	Public Relations	N112W18741 Mequon Rd;GV	Kwik Trip GV	NRPT	741	DPK0106
25-016084	10/06/25 13:13	Public Relations	W130N10200 Town 9 Pkwy;GV	DPW GV	NRPT	733	MMO1119
25-016059	10/06/25 07:01	Public Relations	N118W15860 Williams Dr;GV	Kennedy Middle School	NRPT	733	MMO1119
25-016044	10/05/25 22:47	Public Relations	N112W18741 Mequon Rd;GV	Kwik Trip GV	NRPT	743	JAR0107
25-016031	10/05/25 12:11	Public Relations	N112W16268 Mequon Rd;GV	Jimmy Johns Vgtn	NRPT	736	JLS084
25-016023	10/05/25 11:00	Public Relations	W156N10041 Pilgrim Rd;GV	Cross Way Church	NRPT	750	AML9130
25-016022	10/05/25 10:47	Public Relations	W164N11325 Squire Dr;GV	Life Church	NRPT	736	JLS084
25-016016	10/05/25 09:47	Public Relations	W172N11183 Division Rd;GV	Faith Lutheran Church	NRPT	733	MMO1119
25-016015	10/05/25 09:45	Public Relations	N112W18741 Mequon Rd;GV	Kwik Trip GV	NRPT	750	AML9130
25-016012	10/05/25 09:20	Public Relations	N108W14290 Bel Aire La;GV	Bethlehem Lutheran Church	NRPT	750	AML9130
25-015989	10/04/25 21:20	Public Relations	W190N9855 Appleton Av;STORE;GV	Walmart VGTN	NRPT	741	DPK0106
25-015981	10/04/25 18:03	Public Relations	W188N10515 Maple Rd;GV	Buzdums Pub	NRPT	741	DPK0106
25-015976	10/04/25 16:10	Public Relations	N112W18741 Mequon Rd;GV	Kwik Trip GV	NRPT	741	DPK0106
25-015960	10/04/25 09:09	Public Relations	N112W18741 Mequon Rd;GV	Kwik Trip GV	NRPT	738	NWK1173



Call Simple Lists

Printed On: 11/24/25 12:57

Call#	Reported Date	CAD CFS	Location	Common Name	Disp	Unit#	Officer(s)
25-015950	10/04/25 04:23	Public Relations	N112W18741 Mequon Rd;GV	Kwik Trip GV	NRPT	748	TSW9112
25-015944	10/04/25 01:33	Public Relations	N112W18741 Mequon Rd;GV	Kwik Trip GV	NRPT	738	NWK1173
25-015909	10/03/25 08:54	Public Relations	W159N9939 Butternut Rd;GV	County Line School	NRPT	731	KCL088
25-015902	10/03/25 06:49	Public Relations	W180N11501 River La;GV	Germantown High School	NRPT	736	JLS084
25-015901	10/03/25 06:40	Public Relations	W140N11492 Country Aire Dr;GV	Friedenfeld Park	NRPT	742	AWD00105
25-015900	10/03/25 06:37	Public Relations	N112W16510 Mequon Rd,A;GV	Starbucks VGTN - Mequon Rd.	NRPT	736	JLS084
25-015899	10/03/25 05:39	Public Relations	N112W18741 Mequon Rd;GV	Kwik Trip GV	NRPT	742	AWD00105
25-015898	10/03/25 04:41	Public Relations	N112W18741 Mequon Rd;GV	Kwik Trip GV	NRPT	707	JR098
25-015854	10/02/25 10:04	Public Relations	N112W18741 Mequon Rd;GV	Kwik Trip GV	NRPT	707	JR098
25-015852	10/02/25 09:40	Public Relations	N112W18741 Mequon Rd;GV	Kwik Trip GV	NRPT	751	DJP083
25-015850	10/02/25 09:16	Public Relations	N112W18741 Mequon Rd;GV	Kwik Trip GV	NRPT	736	JLS084
25-015847	10/02/25 08:45	Public Relations	N112W18741 Mequon Rd;GV	Kwik Trip GV	NRPT	747	BPD9058
25-015845	10/02/25 07:59	Public Relations	W159N9939 Butternut Rd;GV	County Line School	NRPT	736	JLS084
25-015843	10/02/25 07:22	Public Relations	N118W15860 Williams Dr;GV	Kennedy Middle School	NRPT	751	DJP083
25-015842	10/02/25 07:21	Public Relations	N108W14290 Bel Aire La;GV	Bethlehem Lutheran Church	NRPT	736	JLS084
25-015802	10/01/25 08:08	Public Relations	W159N9939 Butternut Rd;GV	County Line School	NRPT	707	JR098
25-015797	10/01/25 07:00	Public Relations	N118W15860 Williams Dr;GV	Kennedy Middle School	NRPT	750	AML9130
25-015792	10/01/25 03:37	Public Relations	W188N10963 Maple Rd;GV	Kwik Trip GV - VACANT BLDG Kwik Trip GV	NRPT	733	MMO119
25-015789	10/01/25 02:38	Public Relations	W177N11486 Blackstone Cir;GV		NRPT	746	TJN9088
25-015788	10/01/25 02:34	Public Relations	N116W17866 Blackstone Cir;GV		NRPT	746	TJN9088

Village of Germantown Police

Roll Call



The Vault

25-016369	K9 Other	Disposition	No Report Due
10/11/25 10:0014	W162N11870 Park Av	Unit	730
		Officer	TE0138

K9 Pet Fest Howl-O-Ween Event

25-016370	K9 Drugs	Disposition	No Report Due
10/11/25 10:0306	Hy 41 NB/Holy Hill Rd	Unit	710
		Officer	JLP137

Sgt conducted a K9 sniff on WI VIN: 1HGCG32222A005658 ref GPD traffic stop #25-16367. The K9 indicated for drugs by scratching the front driver side door handle of the vehicle. Sgt seized one handgun, 20.84 grams of cocaine, 25 grams of marijuana, 320 Gabapentin pills, 6 Alprazolam pills, 55 Suboxone strips, \$402.00, and drug paraphernalia.

25-016374	K9 Other	Disposition	No Report Due
10/11/25 12:4624	W162N11870 Park Av	Unit	710
		Officer	JLP137

K9 Demonstration for Pet Fest fundraiser

25-016530	K9 Drugs	Disposition	No Report Due
10/14/25 08:1152	350 Vine St	Unit	710
		Officer	JLP137

K9 drug sniff at West Bend High School and Badger Middle School

25-016607	K9 Drugs	Disposition	Report Required
10/15/25 16:0824	County Line Rd/HY 41 SB	Unit	710
		Officer	JLP137

Sgt conducted a K9 drug sniff on WI Reg. ANV7543 ref WASO traffic stop #25-37701. The K9 indicated for drugs by scratching the front passenger side door handle of the vehicle. WASO Deputy 466 located .11 grams of cocaine inside of the vehicle.

25-016653	K9 Other	Disposition	No Report Due
10/16/25 16:5735	N115W18752 Edison Dr	Unit	730
		Officer	TE0138

Fire Safety Fair- GTFD

25-016655	K9 Other	Disposition	No Report Due
10/16/25 17:3106	W162N11862 Park Av	Unit	710
		Officer	JLP137

K9 PR at the Germantown Fire Department for the fire safety event

25-017002	K9 Drugs	Disposition	No Report Due
10/22/25 17:4602	HY 45 NB/Hy 41	Unit	710
		Officer	JLP137

Village of Germantown Police



Roll Call

Sgt conducted a K9 drug sniff on WI Reg. AXE1552 ref traffic stop #25-16999. The K9 indicated for drugs by scratching the rear driver side door seam of the vehicle. Old empty THC vapes were located inside of the vehicle.

25-017012	K9 Drugs	Disposition	No Report Due
10/22/25 18:2444	W178N9653 Riversbend La	Unit	710
		Officer	JLP137

Sgt conducted a K9 drug sniff on WI Reg. BBP5086 ref traffic stop warrant arrest #25-17005. The K9 indicated for drugs by scratching the front driver side door handle of the vehicle. Three unprescribed Adderall were located inside of the vehicle.

25-017051	K9 Drugs	Disposition	No Report Due
10/22/25 21:3154	Maple Rd/Kleinmann Dr	Unit	735
		Officer	JRS097 KMK913!

Officer conducted a K9 drug sniff on a blue 2013 Hyundai Elantra WI reg AUH3441 reference 25-16995. No alert.

25-017053	K9 Drugs	Disposition	No Report Due
10/22/25 21:3606	Hy 41 NB/Freistadt Rd	Unit	735
		Officer	JRS097 KMK913!

Officer conducted a K9 drug sniff on a silver 2009 Hunda Pilot WI vin (5FNY48849B014310) reference 25-17017. Positive K9 alert. Cocaine and drug paraphernalia was located inside the vehicle.

25-017054	K9 Drugs	Disposition	No Report Due
10/22/25 21:3905	Hy 41 NB/Pioneer Rd	Unit	735
		Officer	JRS097 KMK913!

Officer conducted a K9 drug sniff reference 25-17033. No alert.

25-017056	K9 Drugs	Disposition	No Report Due
10/22/25 21:4118	W178N9653 Riversbend La	Unit	735
		Officer	JRS097 KMK913!

Officer conducted a K9 drug sniff on a silver 2003 GMC Yukon WI reg ARK4451 reference 25-17037. K9 alerted to the lower driver door seam. Nothing of evidentiary value was located.

25-017072	K9 Drugs	Disposition	No Report Due
10/22/25 23:2018	N112W18741 Mequon Rd	Unit	710
		Officer	JLP137

Sgt conducted a K9 drug sniff on WI Reg. AHB4138 ref GPD traffic stop #25-17069. The K9 indicated for drugs by scratching the front driver side door handle of the vehicle. A small amount of marijuana shake was located inside of the vehicle in marijuana factory packaging.

Village of Germantown Police



Roll Call

25-017096

K9 Drugs

Disposition **No Report Due**

10/23/25 08:5612

Main St/Squire Dr

Unit **710**

Officer **JLP137**

Sgt conducted a K9 drug sniff on WI Reg. BBF6342 ref GPD traffic stop #25-17095. The K9 did not indicate on the vehicle for drugs.

25-017281

K9 Drugs

Disposition **No Report Due**

10/26/25 04:1803

Hy 41 NB/Holy Hill Rd

Unit **710**

Officer **JLP137**

Sgt conducted a K9 drug sniff on WI Reg. BAY9865 ref GPD traffic stop #35-17278. The K9 indicated for drugs by scratching the front driver side door handle of the vehicle. 2.5 grams of THC vape cartridges were located inside of the vehicle.

Reports - Scheduled Time Report

Oct 1, 2025 at 12:00a to Oct 31, 2025 at 11:45p

Displaying: Show time over 40 hours as overtime Schedules: Training, Fourth of July Celebration Positions: Admin Assistant, Clerk, Clerk/Typist, Comm., Crime Prevention, Detective, Drug Unit, Lieutenant Support, Officer, Property Clerk, School Resource Officer, Supervisor, Supervisor Operations, Supervisor Support, Support Specialist, Systems Specialist Time Types: Regular, OT - Training

Member	Shift Start Date	Shift Start Time	Shift Stop Date	Shift Stop Time	Schedule	Position	Time Type	Regular Hours	Overtime Hours
Anjum, Amani	Oct 7, 2025	7:30a	Oct 7, 2025	4:00p	Training	Officer	Regular	8.5	0
Anjum, Amani	Oct 8, 2025	7:30a	Oct 8, 2025	4:00p	Training	Officer	Regular	8.5	0
Anjum, Amani	Oct 9, 2025	7:30a	Oct 9, 2025	4:00p	Training	Officer	Regular	8.5	0
Anjum, Amani	Oct 15, 2025	7:30a	Oct 15, 2025	11:30a	Training	Officer	OT - Training	4	0
Anjum, Amani	Oct 23, 2025	12:00p	Oct 23, 2025	2:00p	Training	Officer	OT - Training	2	0
Anjum, Amani	Oct 27, 2025	12:00p	Oct 27, 2025	2:00p	Training	Officer	OT - Training	2	0
							SUBTOTAL:	33.50	0.00
Bartelt, Adam	Oct 7, 2025	7:30a	Oct 7, 2025	4:00p	Training	Officer	Regular	8.5	0
Bartelt, Adam	Oct 8, 2025	7:30a	Oct 8, 2025	4:00p	Training	Officer	Regular	8.5	0
Bartelt, Adam	Oct 9, 2025	7:30a	Oct 9, 2025	4:00p	Training	Officer	Regular	8.5	0
Bartelt, Adam	Oct 15, 2025	7:30a	Oct 15, 2025	11:30a	Training	Officer	OT - Training	4	0
Bartelt, Adam	Oct 23, 2025	12:00p	Oct 23, 2025	2:00p	Training	Officer	Regular	2	0
Bartelt, Adam	Oct 27, 2025	12:00p	Oct 27, 2025	2:00p	Training	Officer	Regular	2	0
							SUBTOTAL:	33.50	0.00
Bloch, Ryan	Oct 24, 2025	10:00a	Oct 24, 2025	2:00p	Training	Officer	Regular	4	0
Bloch, Ryan	Oct 27, 2025	12:00p	Oct 27, 2025	2:00p	Training	Officer	OT - Training	2	0
							SUBTOTAL:	6.00	0.00
Canfield, Alexander	Oct 21, 2025	8:00a	Oct 21, 2025	10:00a	Training	Officer	OT - Training	2	0
Canfield, Alexander	Oct 29, 2025	8:00a	Oct 29, 2025	4:30p	Training	Officer	Regular	8.5	0
							SUBTOTAL:	10.50	0.00
Clemens, Justin	Oct 1, 2025	8:00a	Oct 1, 2025	4:30p	Training	Supervisor	Regular	8.5	0
Clemens, Justin	Oct 2, 2025	8:00a	Oct 2, 2025	4:30p	Training	Supervisor	Regular	8.5	0
Clemens, Justin	Oct 3, 2025	8:00a	Oct 3, 2025	4:30p	Training	Supervisor	Regular	8.5	0
Clemens, Justin	Oct 7, 2025	7:30a	Oct 7, 2025	4:00p	Training	Officer	Regular	8.5	0
Clemens, Justin	Oct 8, 2025	7:30a	Oct 8, 2025	4:00p	Training	Officer	Regular	6	2.5
Clemens, Justin	Oct 9, 2025	7:30a	Oct 9, 2025	4:00p	Training	Officer	Regular	0	8.5
Clemens, Justin	Oct 13, 2025	8:00a	Oct 13, 2025	4:30p	Training	Supervisor	Regular	0	8.5
Clemens, Justin	Oct 14, 2025	8:00a	Oct 14, 2025	4:30p	Training	Supervisor	Regular	0	8.5
Clemens, Justin	Oct 15, 2025	8:00a	Oct 15, 2025	4:30p	Training	Supervisor	Regular	0	8.5
Clemens, Justin	Oct 16, 2025	8:00a	Oct 16, 2025	4:30p	Training	Supervisor	Regular	0	8.5
Clemens, Justin	Oct 17, 2025	8:00a	Oct 17, 2025	4:30p	Training	Supervisor	Regular	0	8.5
Clemens, Justin	Oct 23, 2025	12:00p	Oct 23, 2025	2:00p	Training	Supervisor	OT - Training	0	2
Clemens, Justin	Oct 24, 2025	6:00a	Oct 24, 2025	10:00a	Training	Officer	OT - Training	0	4
							SUBTOTAL:	40.00	59.50
Dalziel, Alexander	Oct 1, 2025	12:00p	Oct 1, 2025	8:30p	Training	Officer	Regular	8.5	0
Dalziel, Alexander	Oct 2, 2025	8:00a	Oct 2, 2025	4:30p	Training	Officer	Regular	8.5	0
Dalziel, Alexander	Oct 21, 2025	8:00a	Oct 21, 2025	10:00a	Training	Officer	Regular	2	0
Dalziel, Alexander	Oct 27, 2025	12:00p	Oct 27, 2025	2:00p	Training	Officer	Regular	2	0
Dalziel, Alexander	Oct 29, 2025	8:00a	Oct 29, 2025	4:30p	Training	Officer	Regular	8.5	0
							SUBTOTAL:	29.50	0.00
Dorniden, Blake	Oct 23, 2025	12:00p	Oct 23, 2025	2:00p	Training	Officer	OT - Training	2	0
Dorniden, Blake	Oct 24, 2025	10:00a	Oct 24, 2025	2:00p	Training	Officer	OT - Training	4	0
							TOTAL:	620.25	257.50

Member	Shift Start Date	Shift Start Time	Shift Stop Date	Shift Stop Time	Schedule	Position	Time Type	Regular Hours	Overtime Hours
							SUBTOTAL:	6.00	0.00
Farnsworth, Cody	Oct 22, 2025	8:00a	Oct 22, 2025	4:30p	Training	Supervisor	Regular	8.5	0
Farnsworth, Cody	Oct 23, 2025	12:00p	Oct 23, 2025	2:00p	Training	Supervisor	OT - Training	2	0
Farnsworth, Cody	Oct 27, 2025	12:00p	Oct 27, 2025	2:00p	Training	Officer	OT - Training	2	0
							SUBTOTAL:	12.50	0.00
Festge, Tanya	Oct 23, 2025	12:00p	Oct 23, 2025	2:00p	Training	Property Clerk	Regular	2	0
							SUBTOTAL:	2.00	0.00
Hanna, James	Oct 24, 2025	10:00a	Oct 24, 2025	2:00p	Training	Officer	OT - Training	4	0
Hanna, James	Oct 27, 2025	12:00p	Oct 27, 2025	2:00p	Training	Officer	OT - Training	2	0
							SUBTOTAL:	6.00	0.00
Hanson, Eric	Oct 23, 2025	12:00p	Oct 23, 2025	2:00p	Training	Comm.	Regular	2	0
Hanson, Eric	Oct 27, 2025	12:00p	Oct 27, 2025	2:00p	Training	Comm.	Regular	2	0
							SUBTOTAL:	4.00	0.00
Jewell, Keri	Oct 23, 2025	12:00p	Oct 23, 2025	2:00p	Training	Clerk/Typist	Regular	2	0
Jewell, Keri	Oct 29, 2025	8:00a	Oct 29, 2025	10:00a	Training	Clerk/Typist	Regular	2	0
							SUBTOTAL:	4.00	0.00
Jones, Matthew	Oct 7, 2025	7:30a	Oct 7, 2025	5:30p	Training	Officer	Regular	10	0
Jones, Matthew	Oct 8, 2025	7:30a	Oct 8, 2025	4:00p	Training	Officer	Regular	8.5	0
Jones, Matthew	Oct 9, 2025	8:00a	Oct 9, 2025	5:30p	Training	Officer	Regular	9.5	0
Jones, Matthew	Oct 15, 2025	7:30a	Oct 15, 2025	11:30a	Training	Officer	Regular	4	0
Jones, Matthew	Oct 21, 2025	8:00a	Oct 21, 2025	10:00a	Training	Officer	Regular	2	0
Jones, Matthew	Oct 27, 2025	12:00p	Oct 27, 2025	2:00p	Training	Officer	Regular	2	0
							SUBTOTAL:	36.00	0.00
Jones, Shawn	Oct 23, 2025	12:00p	Oct 23, 2025	2:00p	Training	Officer	Regular	2	0
							SUBTOTAL:	2.00	0.00
Kaminski, Daniel	Oct 7, 2025	7:30a	Oct 7, 2025	4:00p	Training	Officer	Regular	8.5	0
Kaminski, Daniel	Oct 8, 2025	7:30a	Oct 8, 2025	4:00p	Training	Officer	Regular	8.5	0
Kaminski, Daniel	Oct 9, 2025	7:30a	Oct 9, 2025	4:00p	Training	Officer	Regular	8.5	0
Kaminski, Daniel	Oct 15, 2025	7:30a	Oct 15, 2025	11:30a	Training	Officer	OT - Training	4	0
Kaminski, Daniel	Oct 23, 2025	12:00p	Oct 23, 2025	2:00p	Training	Officer	OT - Training	2	0
Kaminski, Daniel	Oct 24, 2025	10:00a	Oct 24, 2025	2:00p	Training	Officer	OT - Training	4	0
							SUBTOTAL:	35.50	0.00
Kloety, Kyle	Oct 23, 2025	12:00p	Oct 23, 2025	2:00p	Training	Officer	Regular	2	0
Kloety, Kyle	Oct 27, 2025	12:00p	Oct 27, 2025	2:00p	Training	Officer	OT - Training	2	0
							SUBTOTAL:	4.00	0.00
Kuchta, Nicholas	Oct 1, 2025	12:00p	Oct 1, 2025	8:30p	Training	Officer	Regular	8.5	0
Kuchta, Nicholas	Oct 2, 2025	8:00a	Oct 2, 2025	4:30p	Training	Officer	Regular	8.5	0
Kuchta, Nicholas	Oct 20, 2025	8:00a	Oct 20, 2025	5:00p	Training	Officer	Regular	9	0
Kuchta, Nicholas	Oct 21, 2025	8:00a	Oct 21, 2025	5:00p	Training	Officer	Regular	9	0
Kuchta, Nicholas	Oct 22, 2025	8:00a	Oct 22, 2025	5:00p	Training	Officer	Regular	5	4
Kuchta, Nicholas	Oct 23, 2025	8:00a	Oct 23, 2025	5:00p	Training	Officer	Regular	0	9
Kuchta, Nicholas	Oct 24, 2025	8:00a	Oct 24, 2025	3:30p	Training	Officer	Regular	0	7.5
							SUBTOTAL:	40.00	20.50
Laux, Kevin	Oct 23, 2025	12:00p	Oct 23, 2025	2:00p	Training	Officer	Regular	2	0
							SUBTOTAL:	2.00	0.00
							TOTAL:	620.25	257.50

Member	Shift Start Date	Shift Start Time	Shift Stop Date	Shift Stop Time	Schedule	Position	Time Type	Regular Hours	Overtime Hours
Lembke, Aaron	Oct 23, 2025	12:00p	Oct 23, 2025	2:00p	Training	Officer	Regular	2	0
Lembke, Aaron	Oct 24, 2025	10:00a	Oct 24, 2025	2:00p	Training	Officer	Regular	4	0
Lembke, Aaron	Oct 29, 2025	8:00a	Oct 29, 2025	10:00a	Training	Officer	Regular	2	0
							SUBTOTAL:	8.00	0.00
Majkowski, Brock	Oct 1, 2025	8:00a	Oct 1, 2025	4:30p	Training	Supervisor	Regular	8.5	0
Majkowski, Brock	Oct 2, 2025	8:00a	Oct 2, 2025	4:30p	Training	Supervisor	Regular	8.5	0
Majkowski, Brock	Oct 3, 2025	8:00a	Oct 3, 2025	4:30p	Training	Supervisor	Regular	8.5	0
Majkowski, Brock	Oct 4, 2025	8:00a	Oct 4, 2025	4:30p	Training	Supervisor	Regular	8.5	0
Majkowski, Brock	Oct 5, 2025	8:00a	Oct 5, 2025	4:30p	Training	Supervisor	Regular	6	2.5
Majkowski, Brock	Oct 7, 2025	7:30a	Oct 7, 2025	4:00p	Training	Officer	Regular	0	8.5
Majkowski, Brock	Oct 8, 2025	7:30a	Oct 8, 2025	4:00p	Training	Officer	Regular	0	8.5
Majkowski, Brock	Oct 9, 2025	7:30a	Oct 9, 2025	4:00p	Training	Officer	Regular	0	8.5
Majkowski, Brock	Oct 13, 2025	8:00a	Oct 13, 2025	4:30p	Training	Supervisor	Regular	0	8.5
Majkowski, Brock	Oct 14, 2025	8:00a	Oct 14, 2025	4:30p	Training	Supervisor	Regular	0	8.5
Majkowski, Brock	Oct 15, 2025	8:00a	Oct 15, 2025	4:30p	Training	Supervisor	Regular	0	8.5
Majkowski, Brock	Oct 16, 2025	8:00a	Oct 16, 2025	4:30p	Training	Supervisor	Regular	0	8.5
Majkowski, Brock	Oct 17, 2025	8:00a	Oct 17, 2025	4:30p	Training	Supervisor	Regular	0	8.5
Majkowski, Brock	Oct 22, 2025	8:00a	Oct 22, 2025	4:30p	Training	Supervisor	Regular	0	8.5
Majkowski, Brock	Oct 23, 2025	12:00p	Oct 23, 2025	2:00p	Training	Supervisor	OT - Training	0	2
Majkowski, Brock	Oct 24, 2025	6:00a	Oct 24, 2025	2:30p	Training	Officer	Regular	0	8.5
							SUBTOTAL:	40.00	89.50
Medved, Hannah	Oct 23, 2025	12:00p	Oct 23, 2025	2:00p	Training	Comm.	Regular	2	0
Medved, Hannah	Oct 27, 2025	12:00p	Oct 27, 2025	2:00p	Training	Comm.	Regular	2	0
							SUBTOTAL:	4.00	0.00
Merten, Patrick	Oct 21, 2025	8:00a	Oct 21, 2025	10:00a	Training	Supervisor	Regular	2	0
Merten, Patrick	Oct 27, 2025	12:00p	Oct 27, 2025	2:00p	Training	Officer	Regular	2	0
							SUBTOTAL:	4.00	0.00
Mikulec, Daniel	Oct 21, 2025	8:00a	Oct 21, 2025	10:00a	Training	Officer	Regular	2	0
Mikulec, Daniel	Oct 29, 2025	8:00a	Oct 29, 2025	10:00a	Training	Officer	Regular	2	0
							SUBTOTAL:	4.00	0.00
Nisiewicz, Thomas	Oct 21, 2025	8:00a	Oct 21, 2025	10:00a	Training	Officer	OT - Training	2	0
Nisiewicz, Thomas	Oct 24, 2025	6:00a	Oct 24, 2025	10:00a	Training	Officer	OT - Training	4	0
Nisiewicz, Thomas	Oct 29, 2025	8:00a	Oct 29, 2025	4:30p	Training	Officer	Regular	8.5	0
							SUBTOTAL:	14.50	0.00
Nolan, Kelly	Oct 21, 2025	8:00a	Oct 21, 2025	10:15a	Training	Comm.	Regular	2.25	0
Nolan, Kelly	Oct 27, 2025	12:00p	Oct 27, 2025	2:00p	Training	Comm.	Regular	2	0
							SUBTOTAL:	4.25	0.00
Olson, Toni	Oct 23, 2025	12:00p	Oct 23, 2025	2:00p	Training	Officer	Regular	2	0
Olson, Toni	Oct 24, 2025	10:00a	Oct 24, 2025	2:00p	Training	Officer	Regular	4	0
							SUBTOTAL:	6.00	0.00
Onela, Michael	Oct 23, 2025	12:00p	Oct 23, 2025	2:00p	Training	Officer	Regular	2	0
							SUBTOTAL:	2.00	0.00
Pabich, Daniel	Oct 23, 2025	12:00p	Oct 23, 2025	2:00p	Training	Officer	OT - Training	2	0
Pabich, Daniel	Oct 24, 2025	6:00a	Oct 24, 2025	10:00a	Training	Officer	Regular	4	0
Pabich, Daniel	Oct 27, 2025	12:00p	Oct 27, 2025	2:00p	Training	Officer	Regular	2	0
							TOTAL:	620.25	257.50

Germantown Police Department - Members Only - Reports

Member	Shift Start Date	Shift Start Time	Shift Stop Date	Shift Stop Time	Schedule	Position	Time Type	Regular Hours	Overtime Hours
SUBTOTAL:								8.00	0.00
Pesch, Justin	Oct 23, 2025	12:00p	Oct 23, 2025	2:00p	Training	Supervisor	Regular	2	0
Pesch, Justin	Oct 28, 2025	8:00a	Oct 28, 2025	4:30p	Training	Supervisor	Regular	8.5	0
Pesch, Justin	Oct 30, 2025	8:00a	Oct 30, 2025	4:30p	Training	Supervisor	Regular	8.5	0
SUBTOTAL:								19.00	0.00
Peterson, Jeremy	Oct 1, 2025	8:00a	Oct 1, 2025	4:30p	Training	Supervisor	Regular	8.5	0
Peterson, Jeremy	Oct 2, 2025	8:00a	Oct 2, 2025	4:30p	Training	Supervisor	Regular	8.5	0
Peterson, Jeremy	Oct 3, 2025	8:00a	Oct 3, 2025	4:30p	Training	Supervisor	Regular	8.5	0
Peterson, Jeremy	Oct 13, 2025	8:00a	Oct 13, 2025	4:30p	Training	Supervisor	Regular	8.5	0
Peterson, Jeremy	Oct 14, 2025	8:00a	Oct 14, 2025	4:30p	Training	Supervisor	Regular	6	2.5
Peterson, Jeremy	Oct 15, 2025	8:00a	Oct 15, 2025	4:30p	Training	Supervisor	Regular	0	8.5
Peterson, Jeremy	Oct 16, 2025	8:00a	Oct 16, 2025	4:30p	Training	Supervisor	Regular	0	8.5
Peterson, Jeremy	Oct 17, 2025	8:00a	Oct 17, 2025	4:30p	Training	Supervisor	Regular	0	8.5
Peterson, Jeremy	Oct 21, 2025	8:00a	Oct 21, 2025	10:00a	Training	Officer	OT - Training	0	2
SUBTOTAL:								40.00	30.00
Preisler, Andrew	Oct 21, 2025	8:00a	Oct 21, 2025	10:00a	Training	Officer	Regular	2	0
Preisler, Andrew	Oct 27, 2025	12:00p	Oct 27, 2025	2:00p	Training	Officer	OT - Training	2	0
SUBTOTAL:								4.00	0.00
Rechlicz, Justin	Oct 23, 2025	12:00p	Oct 23, 2025	12:45p	Training	Supervisor	Regular	0.75	0
Rechlicz, Justin	Oct 24, 2025	6:00a	Oct 24, 2025	10:00a	Training	Officer	Regular	4	0
Rechlicz, Justin	Oct 27, 2025	12:00p	Oct 27, 2025	2:00p	Training	Officer	Regular	2	0
SUBTOTAL:								6.75	0.00
Roecker, Jacob	Oct 21, 2025	8:00a	Oct 21, 2025	10:00a	Training	Officer	OT - Training	2	0
Roecker, Jacob	Oct 24, 2025	6:00a	Oct 24, 2025	10:00a	Training	Officer	OT - Training	4	0
SUBTOTAL:								6.00	0.00
Ross, Carrie	Oct 21, 2025	8:00a	Oct 21, 2025	10:15a	Training	Comm.	Regular	2.25	0
Ross, Carrie	Oct 27, 2025	12:00p	Oct 27, 2025	2:00p	Training	Comm.	Regular	2	0
SUBTOTAL:								4.25	0.00
Schmitt, Penny	Oct 21, 2025	8:00a	Oct 21, 2025	10:00a	Training	Officer	Regular	2	0
Schmitt, Penny	Oct 27, 2025	12:00p	Oct 27, 2025	2:00p	Training	Officer	Regular	2	0
SUBTOTAL:								4.00	0.00
Schmittinger, Jayna	Oct 23, 2025	12:00p	Oct 23, 2025	2:00p	Training	Officer	Regular	2	0
SUBTOTAL:								2.00	0.00
Schulz, Zach	Oct 1, 2025	8:00a	Oct 1, 2025	4:30p	Training	Supervisor	Regular	8.5	0
Schulz, Zach	Oct 2, 2025	8:00a	Oct 2, 2025	4:30p	Training	Supervisor	Regular	8.5	0
Schulz, Zach	Oct 3, 2025	8:00a	Oct 3, 2025	4:30p	Training	Supervisor	Regular	8.5	0
Schulz, Zach	Oct 7, 2025	7:30a	Oct 7, 2025	4:00p	Training	Officer	Regular	8.5	0
Schulz, Zach	Oct 8, 2025	7:30a	Oct 8, 2025	4:00p	Training	Officer	Regular	6	2.5
Schulz, Zach	Oct 9, 2025	7:30a	Oct 9, 2025	4:00p	Training	Officer	Regular	0	8.5
Schulz, Zach	Oct 13, 2025	8:00a	Oct 13, 2025	4:30p	Training	Supervisor	Regular	0	8.5
Schulz, Zach	Oct 14, 2025	8:00a	Oct 14, 2025	4:30p	Training	Supervisor	Regular	0	8.5
Schulz, Zach	Oct 15, 2025	8:00a	Oct 15, 2025	4:30p	Training	Supervisor	Regular	0	8.5
Schulz, Zach	Oct 16, 2025	8:00a	Oct 16, 2025	4:30p	Training	Supervisor	Regular	0	8.5
Schulz, Zach	Oct 17, 2025	8:00a	Oct 17, 2025	4:30p	Training	Supervisor	Regular	0	8.5
SUBTOTAL:								40.00	53.50
Spreiter, Jared	Oct 1, 2025	8:00a	Oct 1, 2025	4:30p	Training	Officer	Regular	8.5	0
TOTAL:								620.25	257.50

Member	Shift Start Date	Shift Start Time	Shift Stop Date	Shift Stop Time	Schedule	Position	Time Type	Regular Hours	Overtime Hours
Spreiter, Jared	Oct 2, 2025	8:00a	Oct 2, 2025	4:30p	Training	Officer	OT - Training	8.5	0
Spreiter, Jared	Oct 3, 2025	8:00a	Oct 3, 2025	4:30p	Training	Officer	OT - Training	8.5	0
Spreiter, Jared	Oct 15, 2025	7:30a	Oct 15, 2025	11:30a	Training	Officer	OT - Training	4	0
Spreiter, Jared	Oct 23, 2025	12:00p	Oct 23, 2025	2:00p	Training	Supervisor	OT - Training	2	0
SUBTOTAL:								31.50	0.00
Von Bereghy, Darren	Oct 7, 2025	7:30a	Oct 7, 2025	4:00p	Training	Officer	Regular	8.5	0
Von Bereghy, Darren	Oct 8, 2025	7:30a	Oct 8, 2025	4:00p	Training	Officer	Regular	8.5	0
Von Bereghy, Darren	Oct 9, 2025	7:30a	Oct 9, 2025	4:00p	Training	Officer	Regular	8.5	0
Von Bereghy, Darren	Oct 10, 2025	8:00a	Oct 10, 2025	4:30p	Training	Officer	Regular	8.5	0
Von Bereghy, Darren	Oct 23, 2025	12:00p	Oct 23, 2025	2:00p	Training	Supervisor	Regular	2	0
Von Bereghy, Darren	Oct 24, 2025	6:00a	Oct 24, 2025	2:30p	Training	Officer	Regular	4	4.5
SUBTOTAL:								40.00	4.50
Whealon, Shaun	Oct 21, 2025	8:00a	Oct 21, 2025	10:00a	Training	Officer	Regular	2	0
SUBTOTAL:								2.00	0.00
Wroblewski, Tyler	Oct 1, 2025	12:00p	Oct 1, 2025	8:30p	Training	Officer	Regular	8.5	0
Wroblewski, Tyler	Oct 2, 2025	8:00a	Oct 2, 2025	4:30p	Training	Officer	Regular	8.5	0
Wroblewski, Tyler	Oct 23, 2025	10:00a	Oct 23, 2025	12:00p	Training	Officer	OT - Training	2	0
SUBTOTAL:								19.00	0.00
TOTAL:								620.25	257.50

October 2025 Training

- 1st Line Supervisor Training – Schulz, Majkowski, Peterson, Clemens
- K9 Certification – Spreiter/Migo
- Advanced Pistol Training – Wroblewski, Dalziel, Kuchta
- Sentinel Concepts/Rifle Training – Majkowski
- SWAT Training – VonBereghy, M. Jones, Schulz, Majkowski, Clemens, Anjum, Bartelt
- SWAT qual/physical – Bartelt, Kaminski, Anjum, Spreiter, M. Jones
- WI Crime Scene Processing – Kuchta
- Sexual Harassment Training – Multiple
- Wrap Safety Training – All
- ADA Training – Multiple
- K9 Training – Pesch/Arek
- Roadside Interviews/Criminal Interdiction – Nisiewicz, Canfield, Dalziel

Scene Locations of Fire Incidents

N = 196 Oct 01, 2025 to Oct 31, 2025

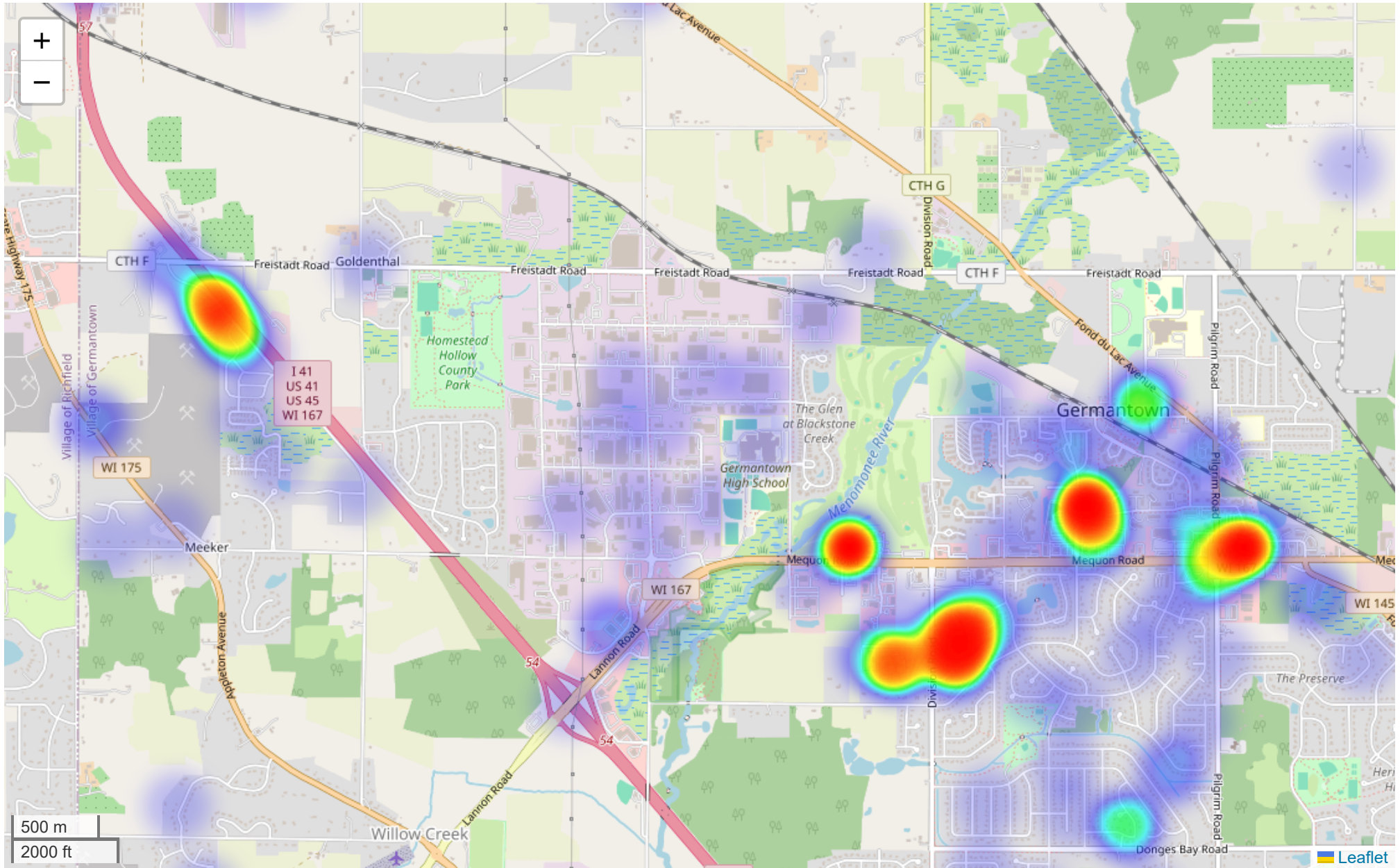

Incidents by Postal Code

Oct 01, 2025 to Oct 31, 2025

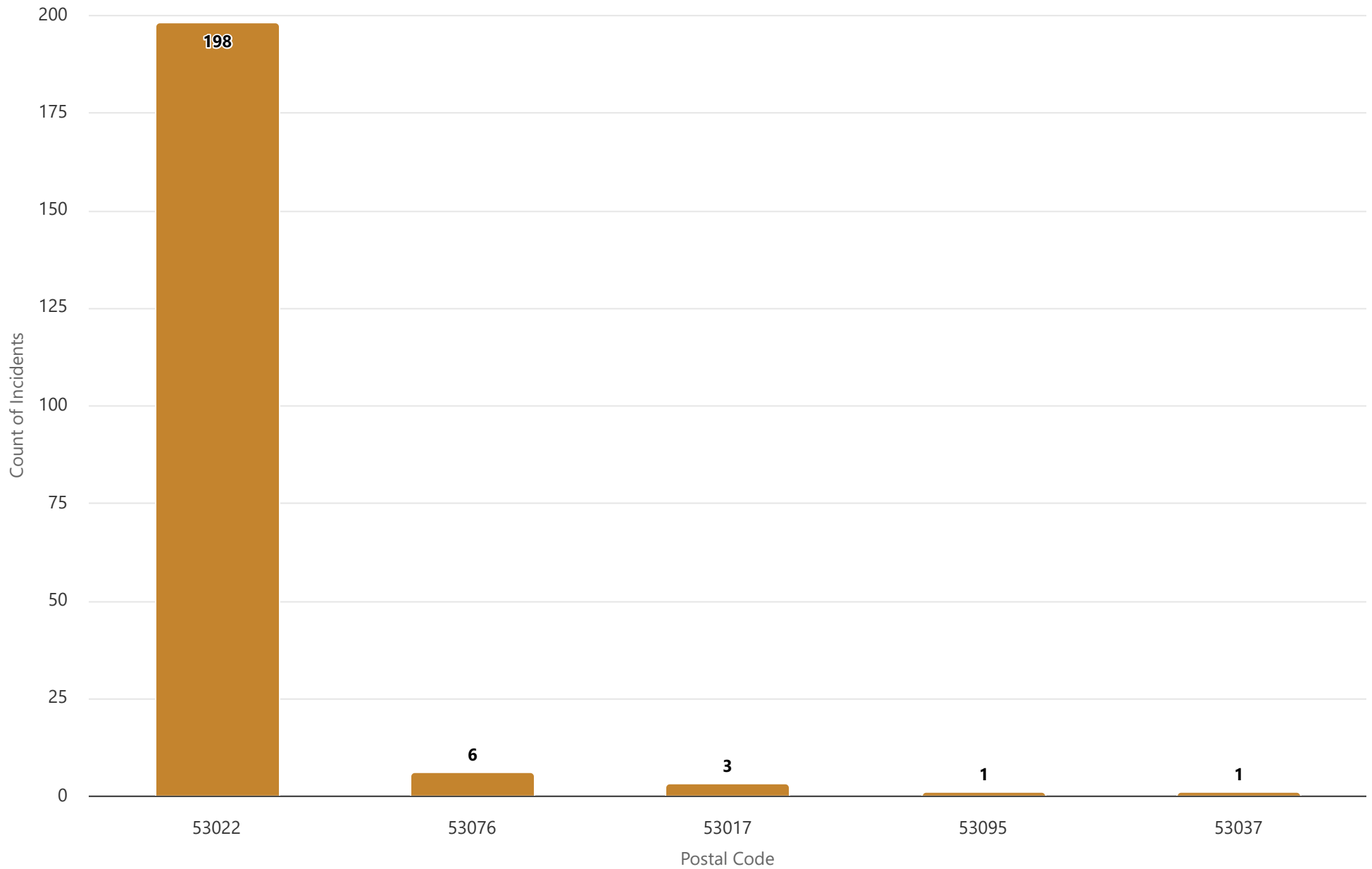

Incidents by City Name (Top 15)

Oct 01, 2025 to Oct 31, 2025

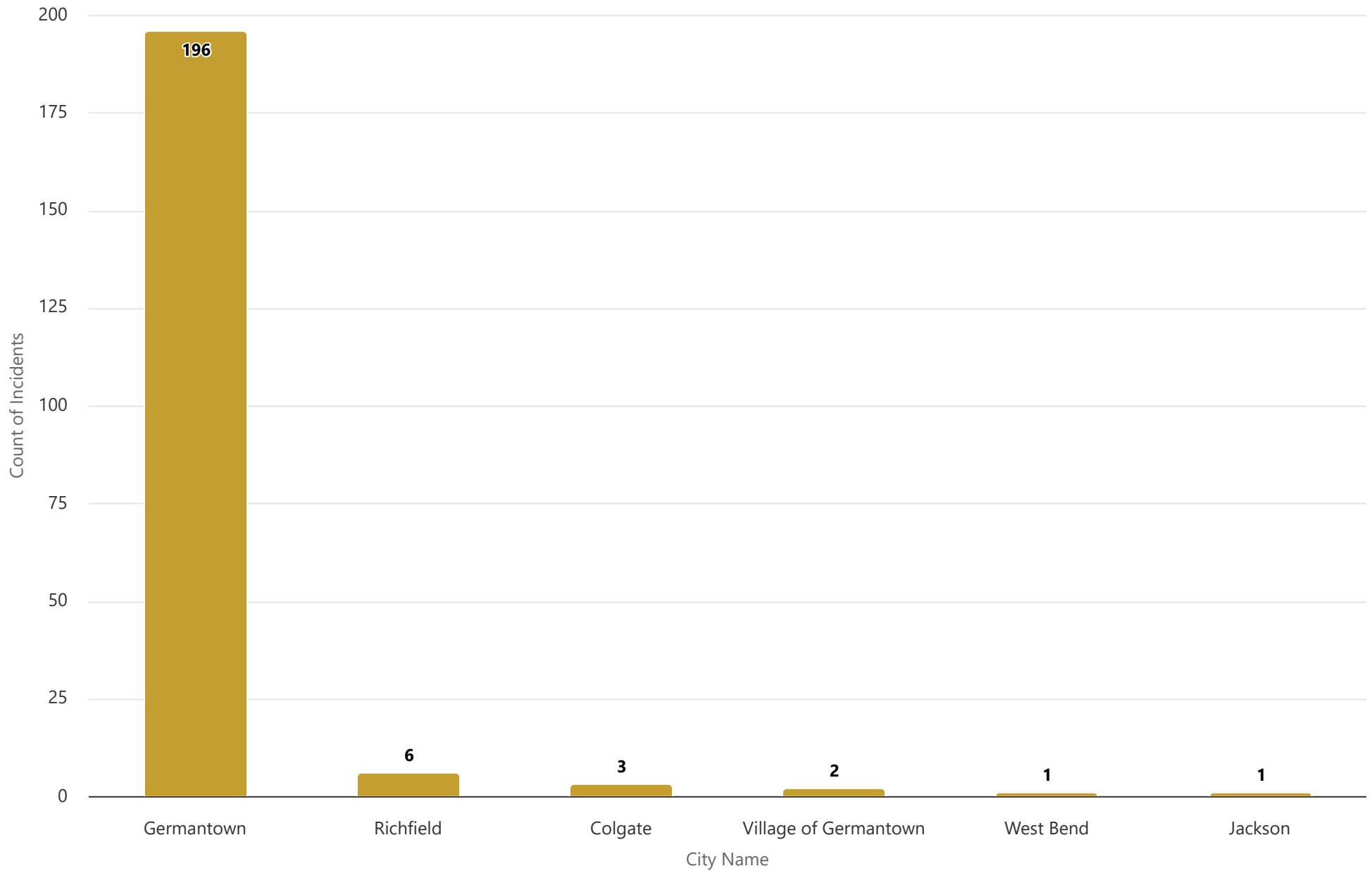

Incidents by County Name (Top 15)

Oct 01, 2025 to Oct 31, 2025

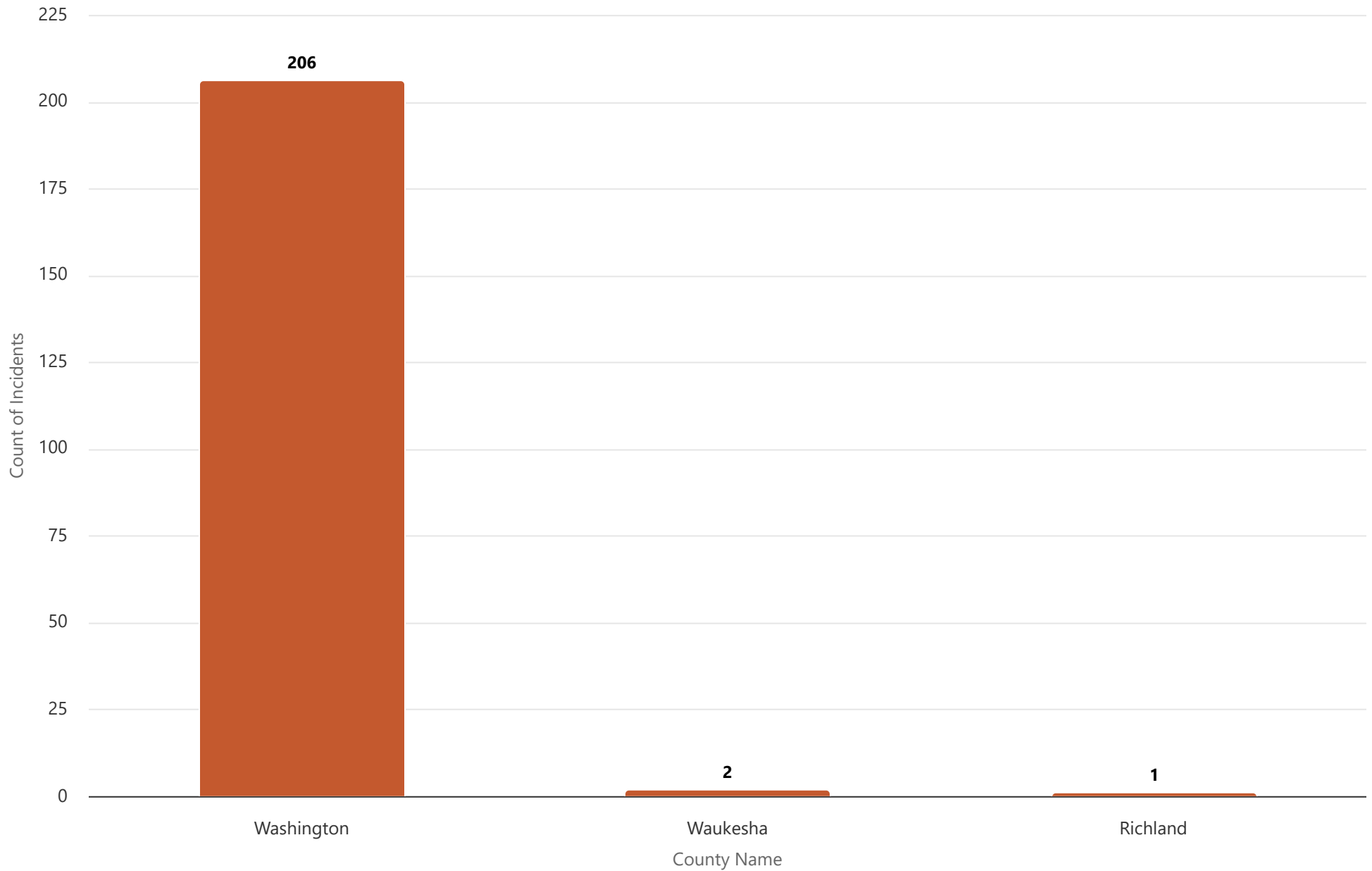

Incidents by Property Use Category

Oct 01, 2025 to Oct 31, 2025

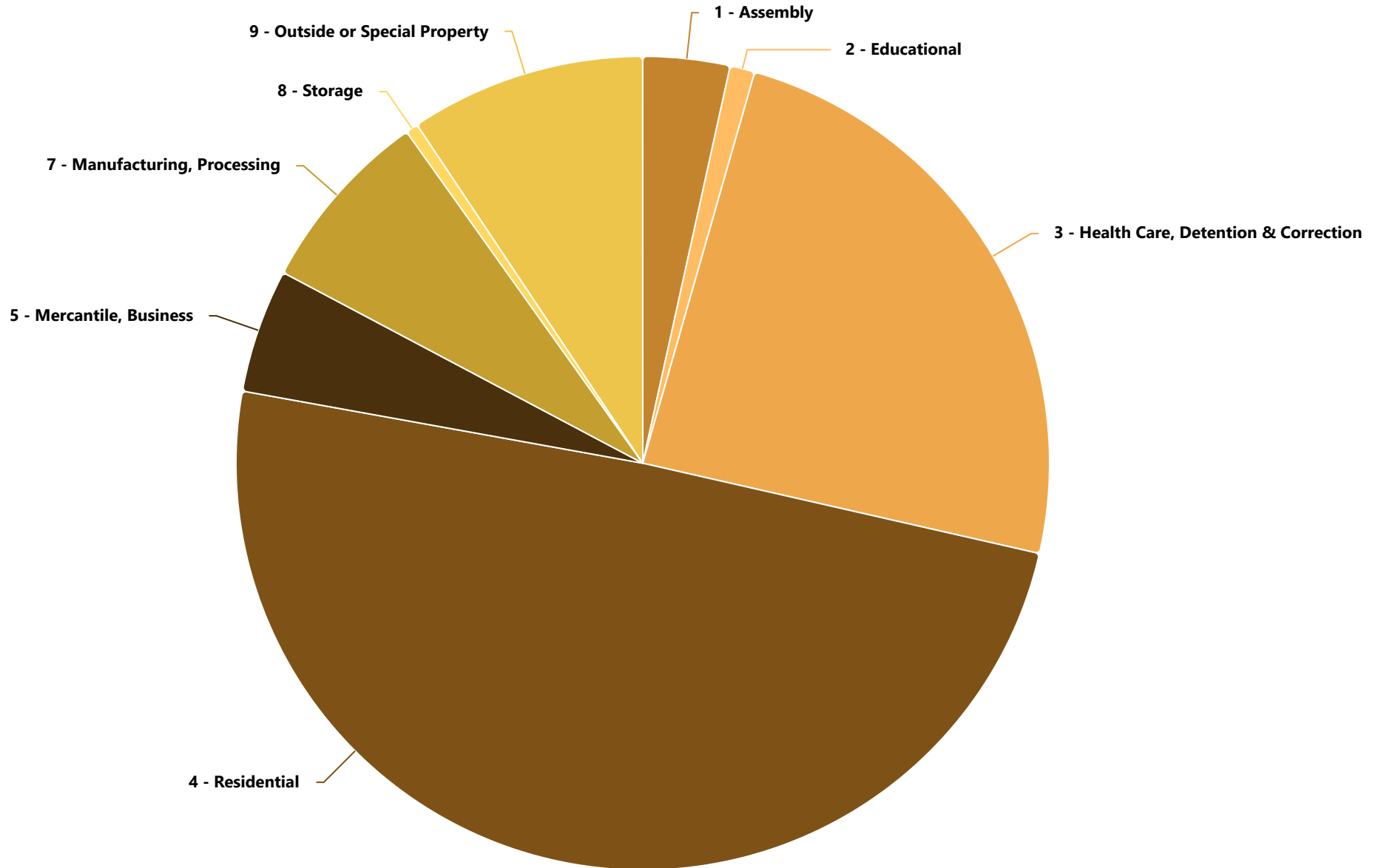

Incidents by Response Mode To Scene

Oct 01, 2025 to Oct 31, 2025

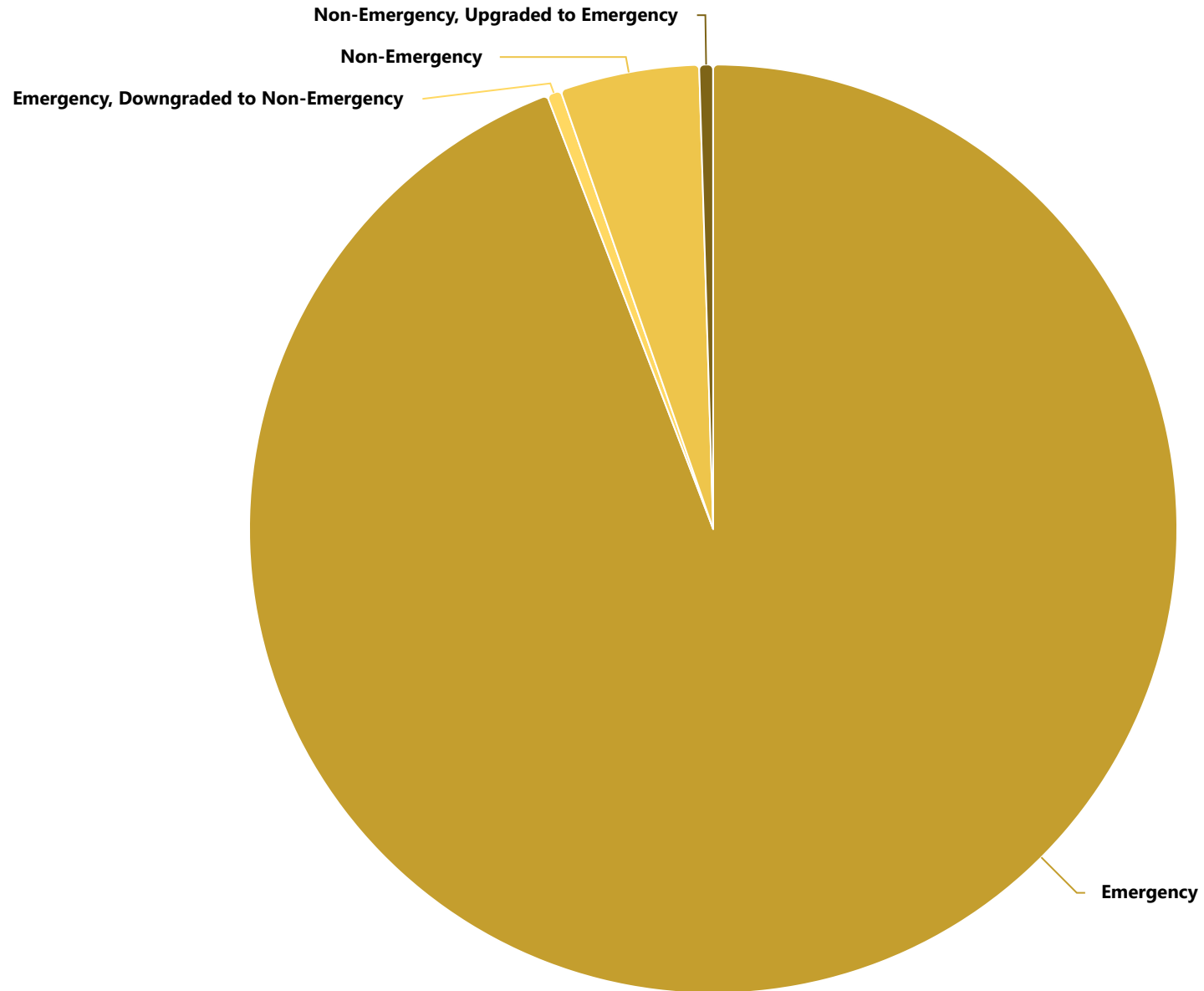

Incidents by District/Zone

Oct 01, 2025 to Oct 31, 2025

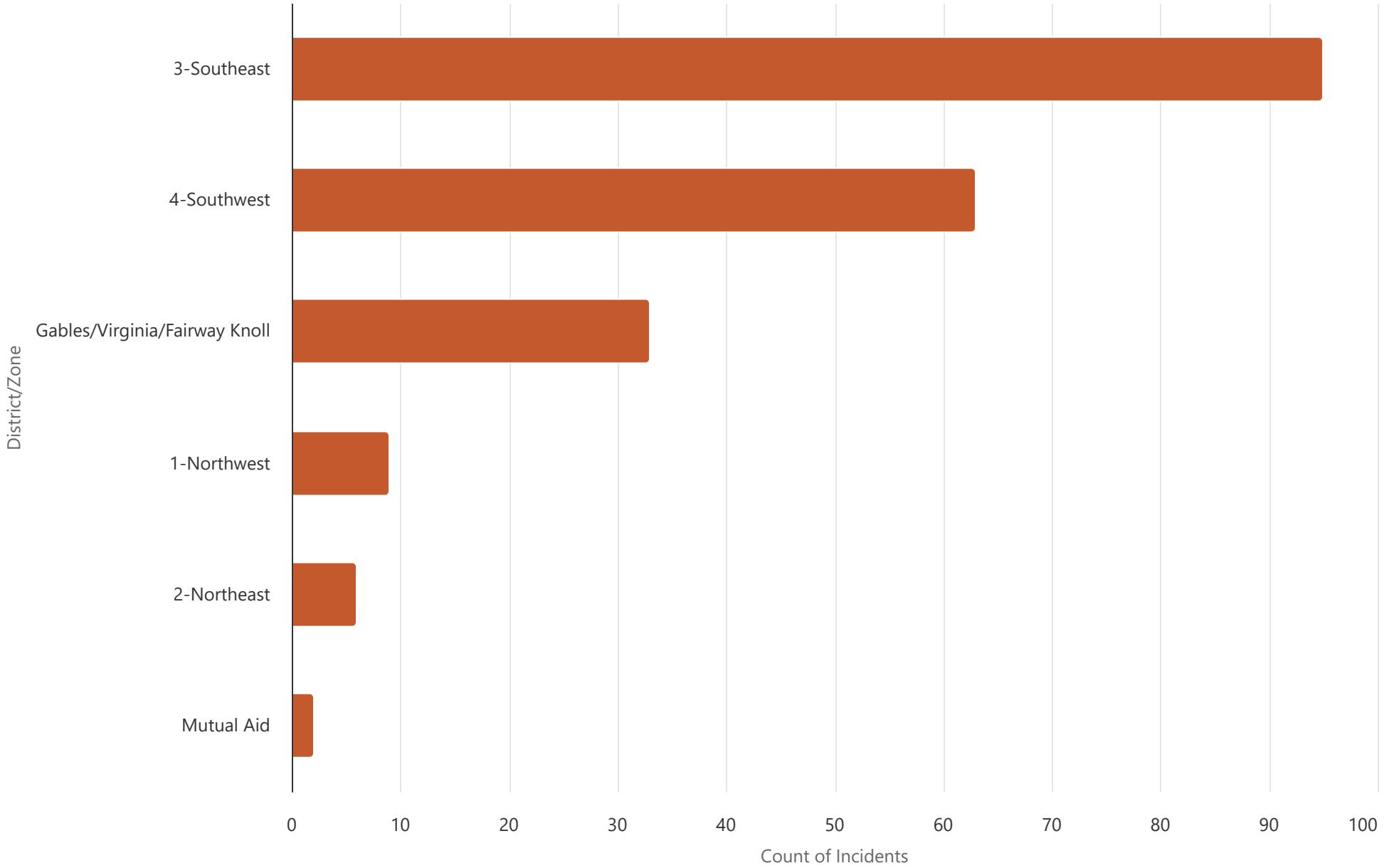

Incidents by District/Zone

Jan 01, 2024 12:00 AM to Oct 31, 2025 11:59 PM

District/Zone	2025										2025		2024		YTD % Change	
	Jan	Feb	Mar	Apr	May	Jun	Jul	Aug	Sep	Oct	Grand Total - Current	% of Total Incidents - Current	Grand Total - Previous	% of Total Incidents - Previous		
1	0	0	0	0	0	0	0	0	0	0	0	0	0.00%	179	21.00%	-100.00%
1-Northwest	0	0	0	11	8	9	7	10	12	9	66	5.00%	2	0.00%	3200.00%	
2	0	0	0	0	0	0	0	0	0	0	0	0.00%	332	38.00%	-100.00%	
2-Northeast	0	0	0	3	5	9	8	5	3	6	39	3.00%	2	0.00%	1850.00%	
3	0	0	0	0	0	0	0	0	0	0	0	0.00%	172	20.00%	-100.00%	
3-Southeast	0	0	0	80	89	104	90	100	74	95	632	44.00%	47	5.00%	1244.68%	
4	0	0	0	0	0	0	0	0	0	0	0	0.00%	26	3.00%	-100.00%	
4-Southwest	0	0	0	44	51	51	61	61	50	63	381	26.00%	25	3.00%	1424.00%	
5	0	0	0	0	0	0	0	0	0	0	0	0.00%	15	2.00%	-100.00%	
6	0	0	0	0	0	0	0	0	0	0	0	0.00%	49	6.00%	-100.00%	
Gables/Virginia/Fairway Knoll	0	0	1	41	60	51	34	44	37	33	301	21.00%	22	3.00%	1268.18%	
Mutual Aid	0	0	0	2	7	2	5	0	2	2	20	1.00%	0	0.00%	N/A	
Grand Total	0	0	1	181	220	226	205	220	178	208	1,439	100.00%	871	100.00%	65.21%	

Incidents by Category and Year

Oct 01, 2025 to Oct 31, 2025

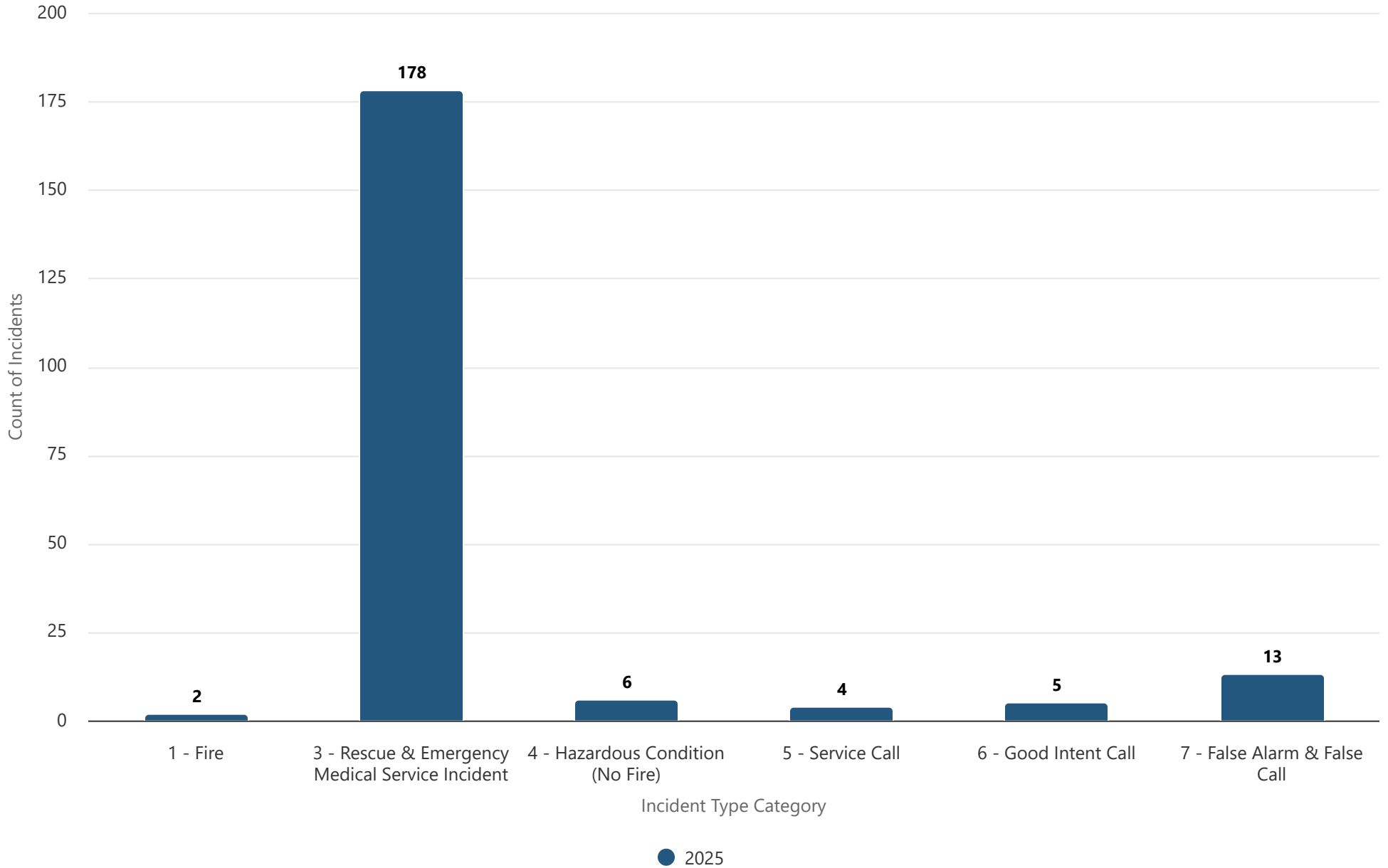

Incident Types (Top 15)

Oct 01, 2025 to Oct 31, 2025

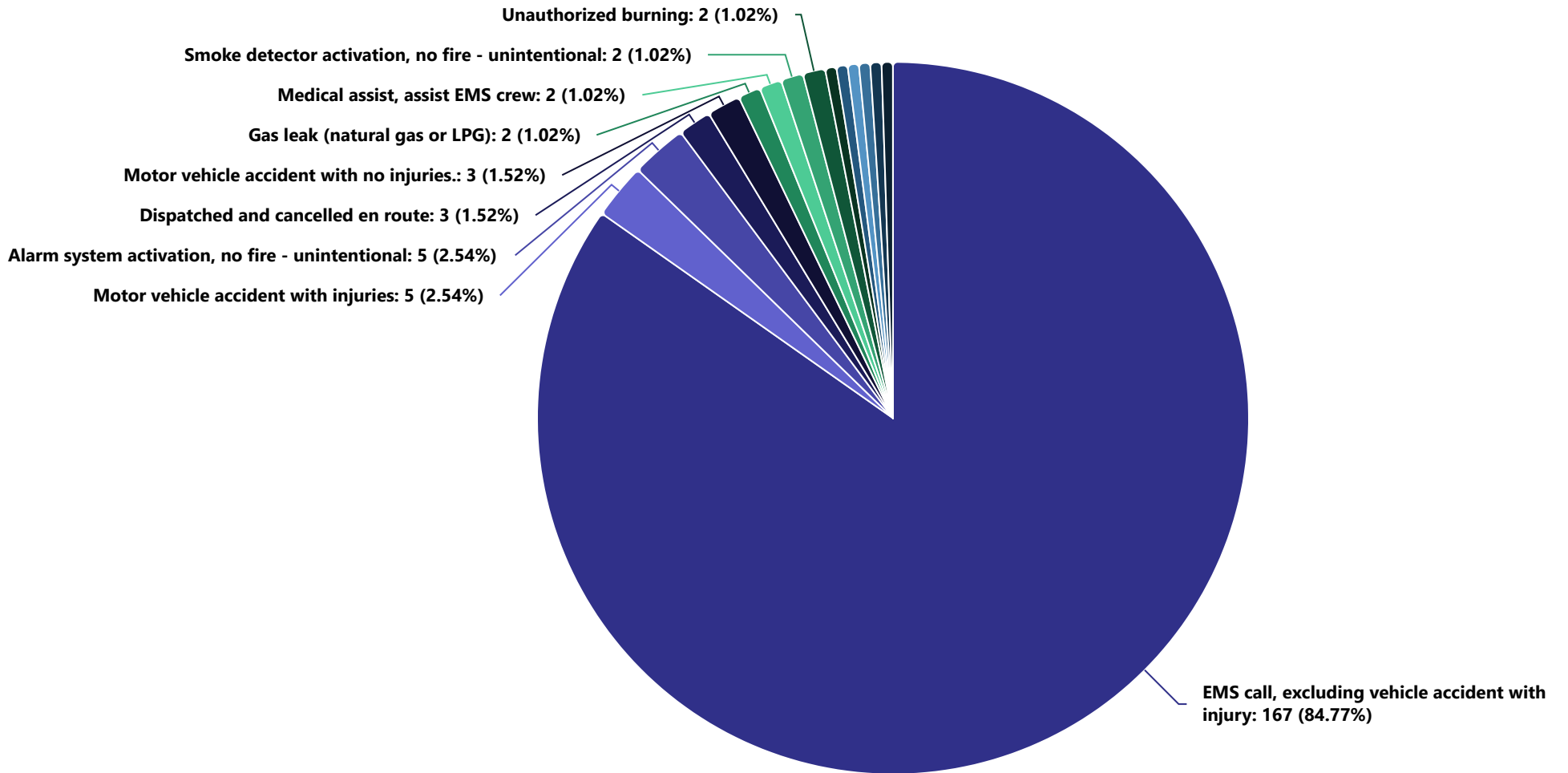

Incident Type Categories

Oct 01, 2025 to Oct 31, 2025

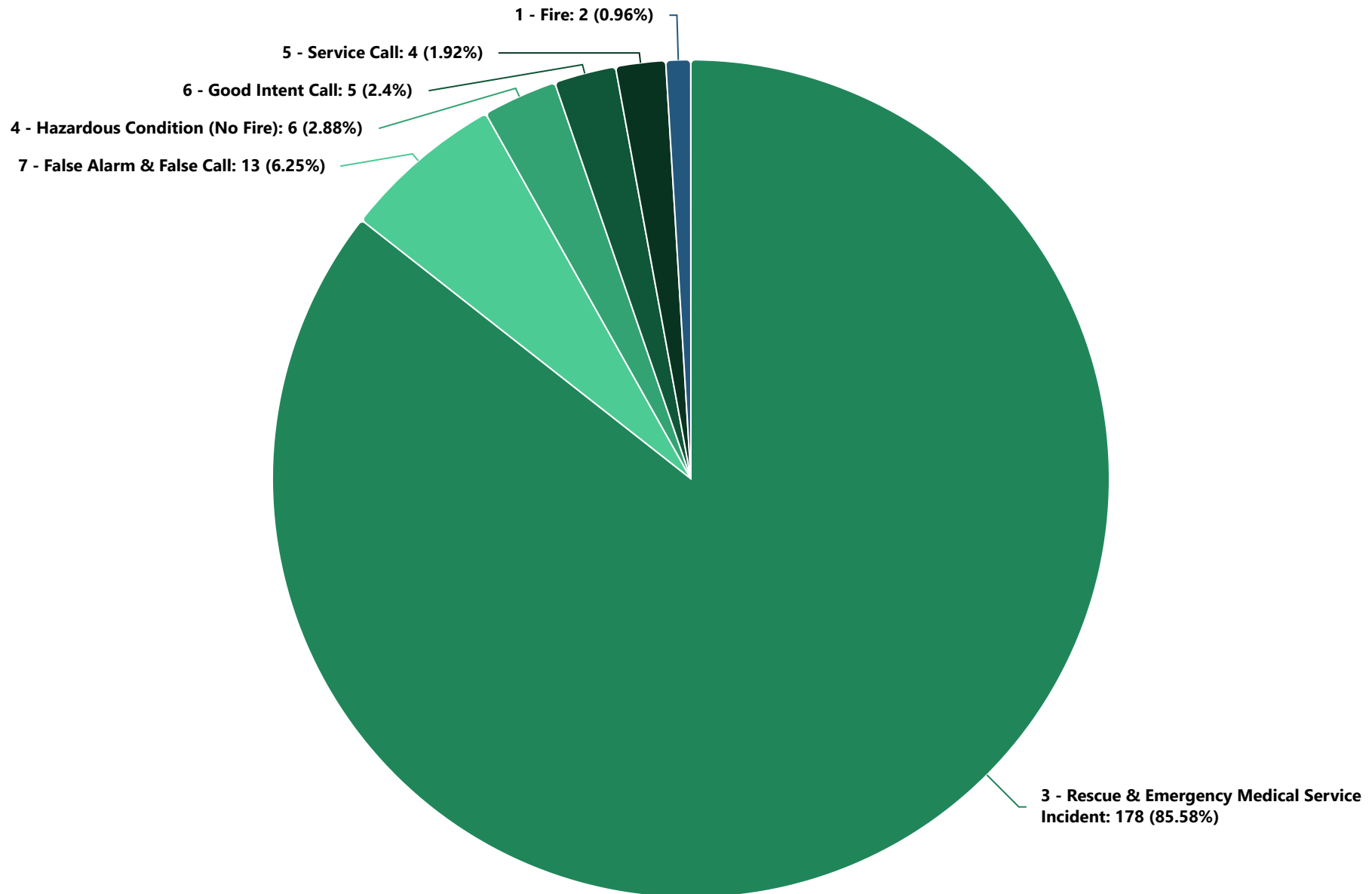

Incidents by Category and Month

Jan 01, 2024 12:00 AM to Oct 31, 2025 11:59 PM

Incident Type Category	2025										2025		2024		YTD % Change
	Jan	Feb	Mar	Apr	May	Jun	Jul	Aug	Sep	Oct	Grand Total - Current	% of Total Incidents - Current	Grand Total - Previous	% of Total Incidents - Previous	
1 - Fire	0	0	0	4	6	0	3	4	3	2	22	2.00%	14	2.00%	57.14%
2 - Overpressure Rupture, Explosion, Overheat (No Fire)	0	0	0	1	0	0	0	3	0	0	4	0.00%	0	0.00%	N/A
3 - Rescue & Emergency Medical Service Incident	0	0	0	146	172	192	159	163	146	178	1,156	80.00%	633	78.00%	82.62%
4 - Hazardous Condition (No Fire)	0	0	0	4	5	5	8	4	2	6	34	2.00%	38	5.00%	-10.53%
5 - Service Call	0	0	0	4	9	3	7	3	5	4	35	2.00%	19	2.00%	84.21%
6 - Good Intent Call	0	0	0	6	3	4	3	11	8	5	40	3.00%	48	6.00%	-16.67%
7 - False Alarm & False Call	0	0	1	15	25	22	23	26	14	13	139	10.00%	57	7.00%	143.86%
8 - Severe Weather & Natural Disaster	0	0	0	0	0	0	0	6	0	0	6	0.00%	0	0.00%	N/A
9 - Special Incident Type	0	0	0	1	0	0	2	0	0	0	3	0.00%	1	0.00%	200.00%
Grand Total	0	0	1	181	220	226	205	220	178	208	1,439	100.00%	810	100.00%	77.65%

Incidents by Apparatus Resource ID (Top 40)

Oct 01, 2025 to Oct 31, 2025

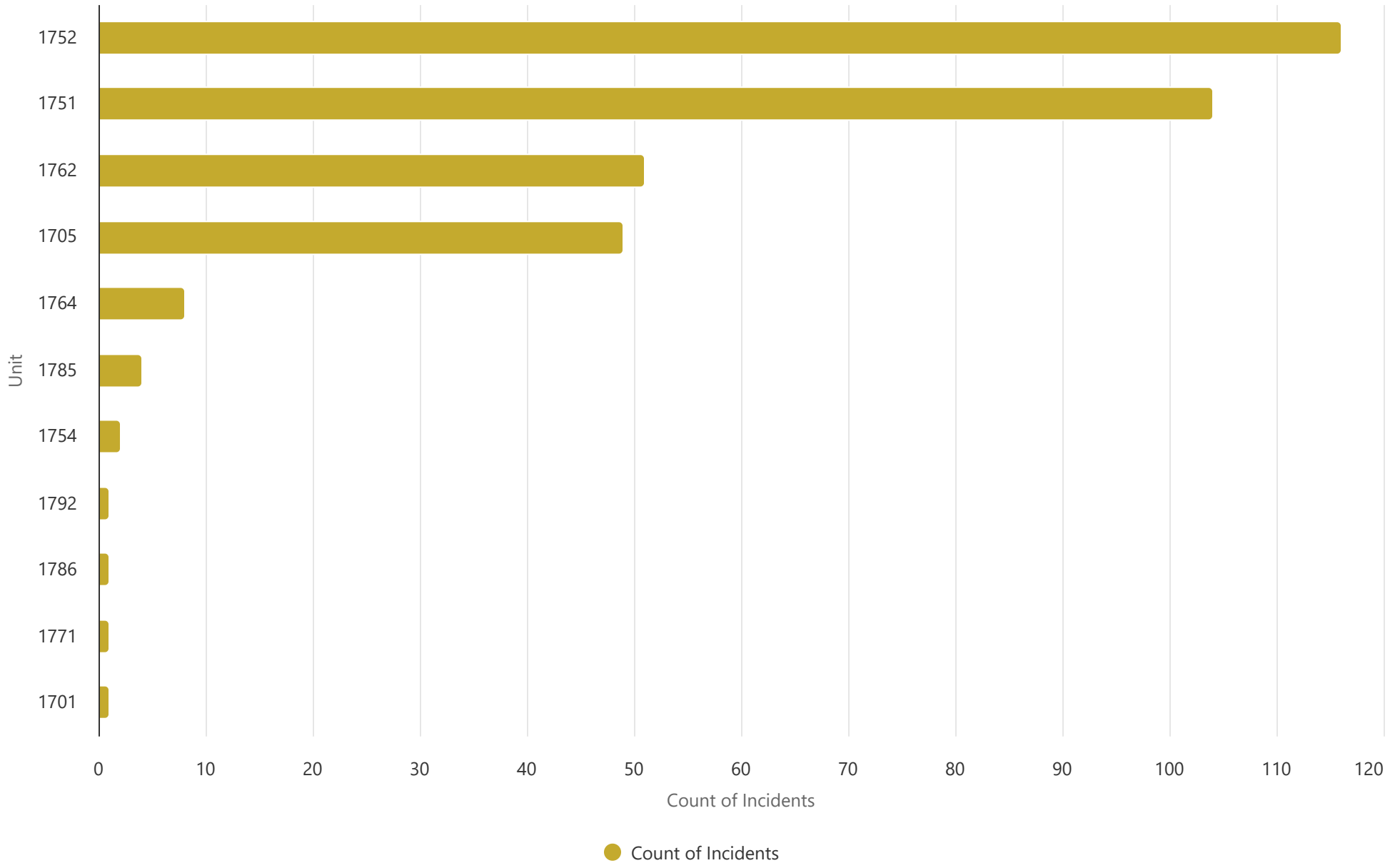

Incidents by Primary Station Name

Oct 01, 2025 to Oct 31, 2025

Values

There are no results to display

Station Summary Report

Oct 01, 2025 to Oct 31, 2025

Station	EMS Incidents	Fire Incidents	Other Incidents	Total Incidents	% of Total Incidents	Station Reliability	90th Percentile Response Time (PSAP to Arrival)
---------	---------------	----------------	-----------------	-----------------	----------------------	---------------------	---

Incidents by Shift

Oct 01, 2025 to Oct 31, 2025

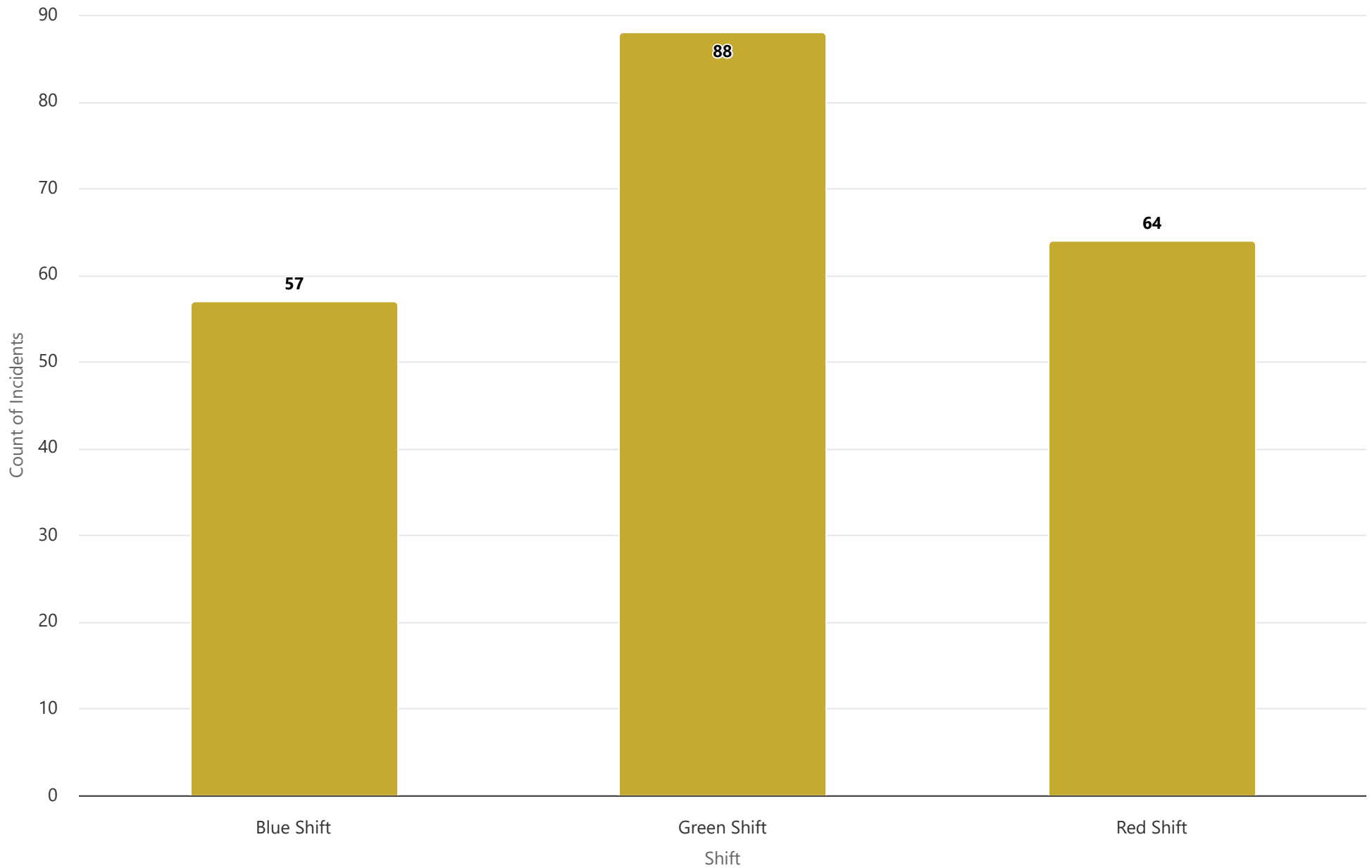

Primary Action Taken Categories by Month

Oct 01, 2025 to Oct 31, 2025

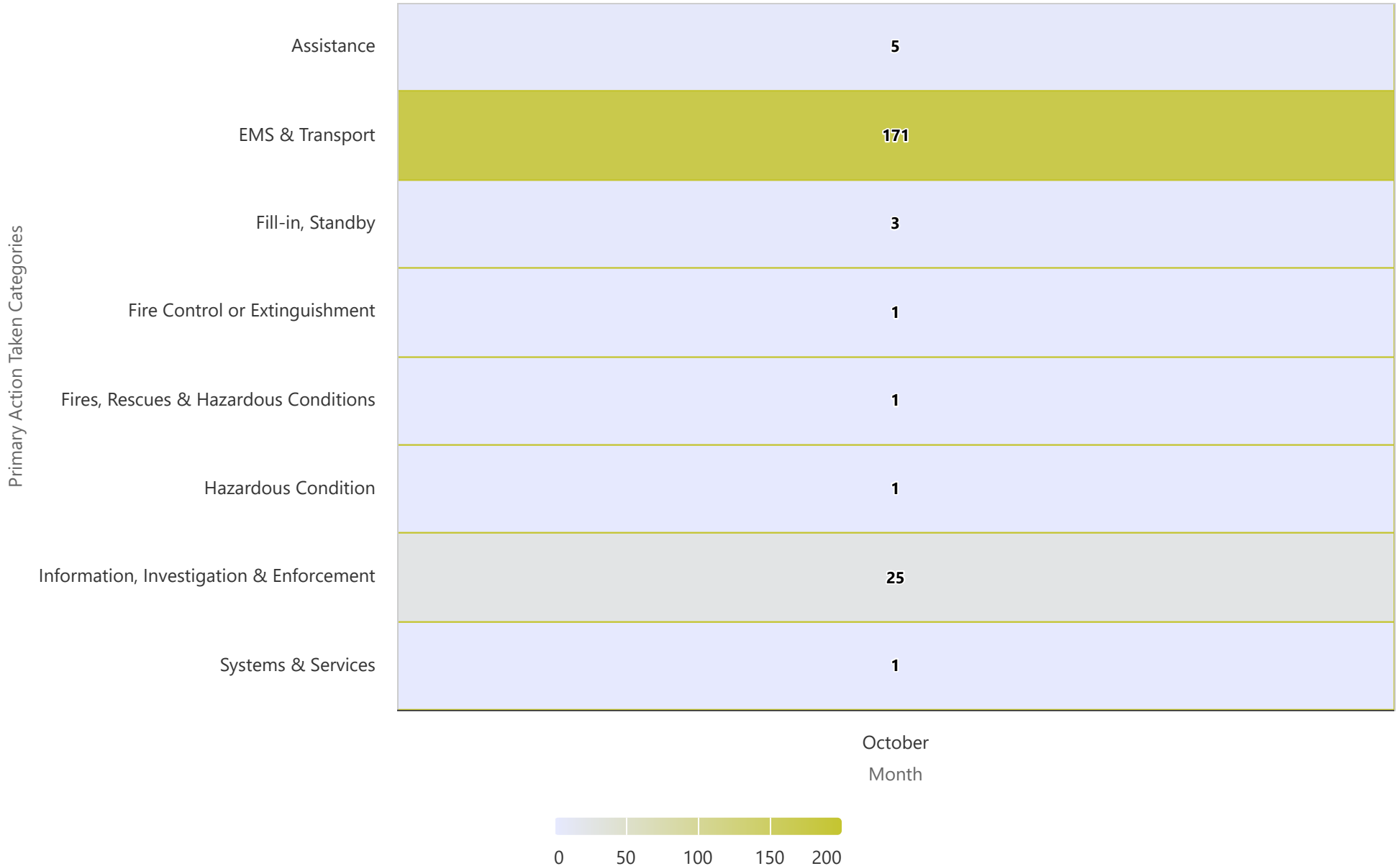

Fire Call Volume by Month

Oct 01, 2025 to Oct 31, 2025

Count of Incidents

209



October
Month

2025

Fire Call Volume by Week

Oct 01, 2025 to Oct 31, 2025

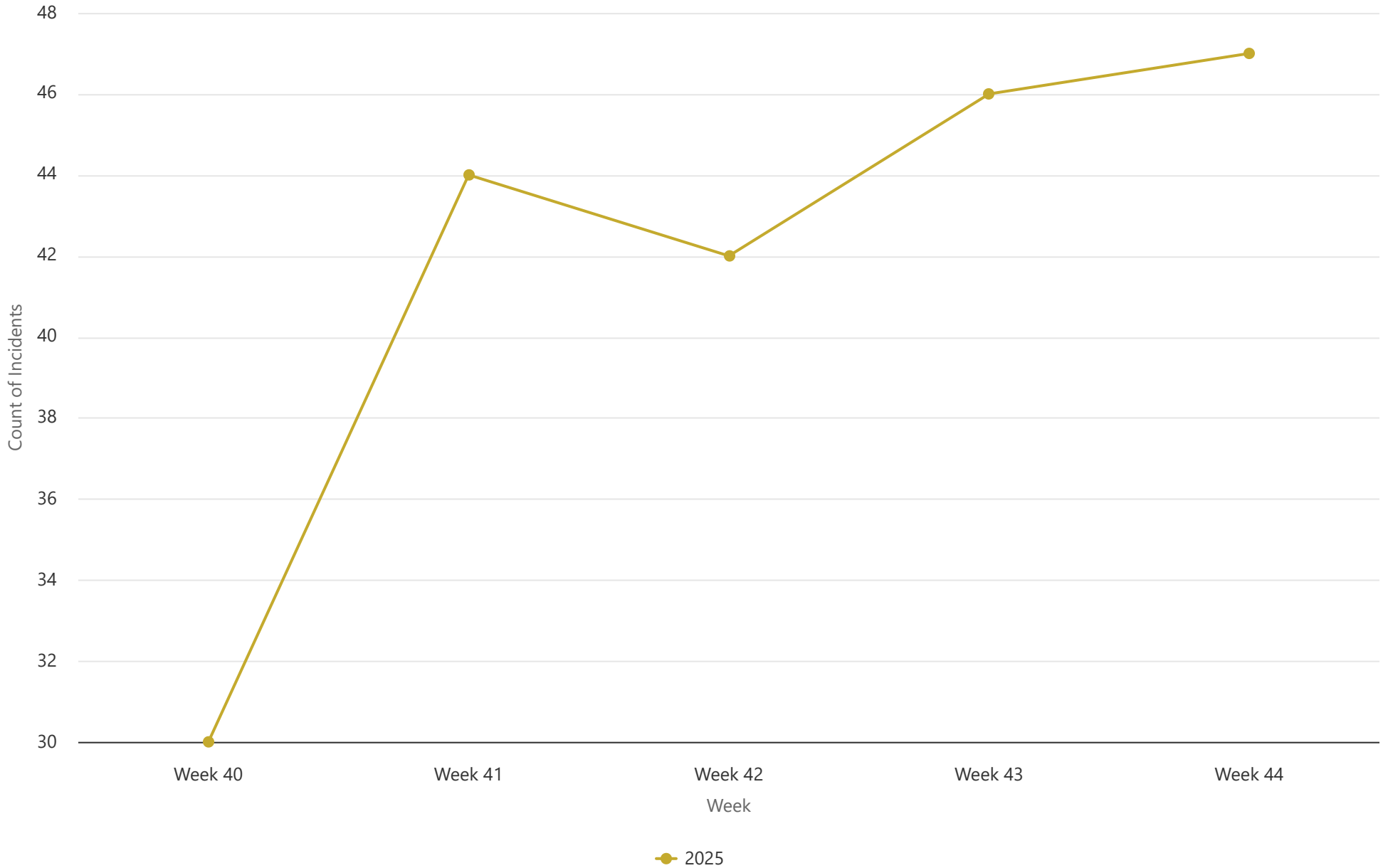

Fire Call Volume by Day

Oct 01, 2025 to Oct 31, 2025

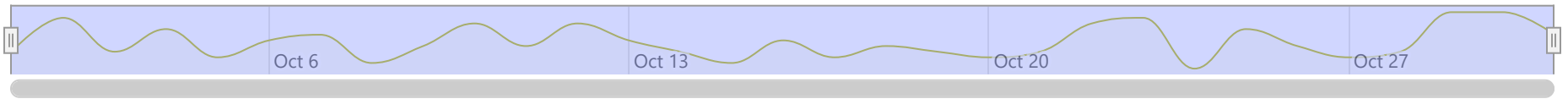
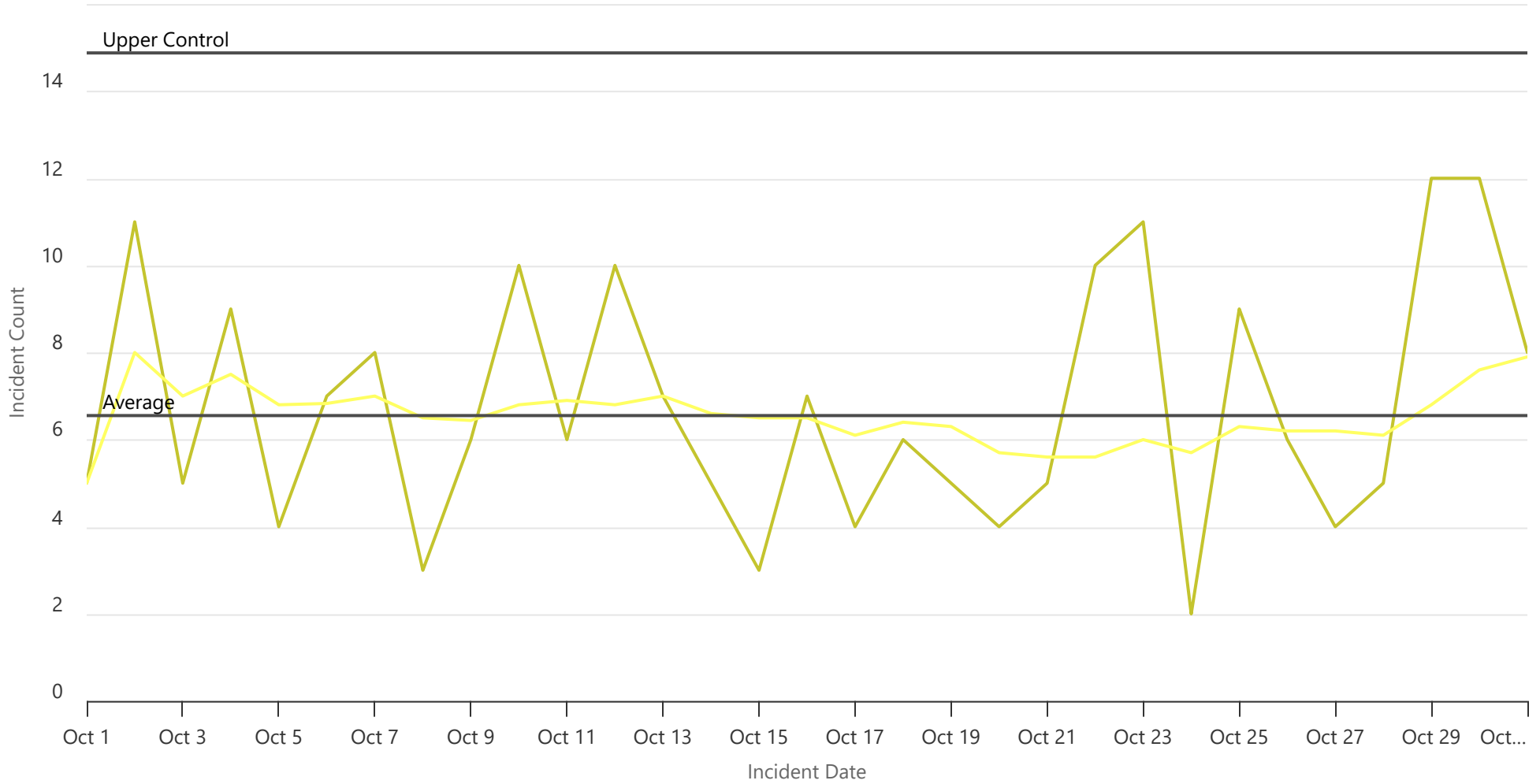

— Daily Incident Count — 10 Day Moving Average Count — Series 3

Aid Given and Received Summary

Oct 01, 2025 to Oct 31, 2025

Fire Department	Automatic Aid Given	% of Total Automatic Aid Given	Automatic Aid Received	% of Total Automatic Aid Received	Mutual Aid Given	% of Total Mutual Aid Given	Mutual Aid Received	% of Total Mutual Aid Received
Hartford Fire Department	0	0.00%	0	0.00%	0	0.00%	1	7.14%
Jackson Fire Department	0	0.00%	0	0.00%	2	100.00%	2	14.29%
Menomonee Falls Fire Department	0	0.00%	0	0.00%	0	0.00%	3	21.43%
Merton Fire Department	0	0.00%	0	0.00%	0	0.00%	1	7.14%
Ozaukee Central Fire Department	0	0.00%	0	0.00%	0	0.00%	1	7.14%
Pewaukee Fire Department	0	0.00%	0	0.00%	0	0.00%	1	7.14%
Richfield Fire Department	0	0.00%	0	0.00%	0	0.00%	1	7.14%
Slinger Fire Department	0	0.00%	0	0.00%	0	0.00%	1	7.14%
Southern Ozaukee Fire Department	0	0.00%	0	0.00%	0	0.00%	2	14.29%
West Bend Fire Department	0	0.00%	0	0.00%	0	0.00%	1	7.14%
Overall	0	0.00%	0	0.00%	2	100.00%	14	100.00%

Aid Given and Received by Year

Oct 01, 2025 to Oct 31, 2025

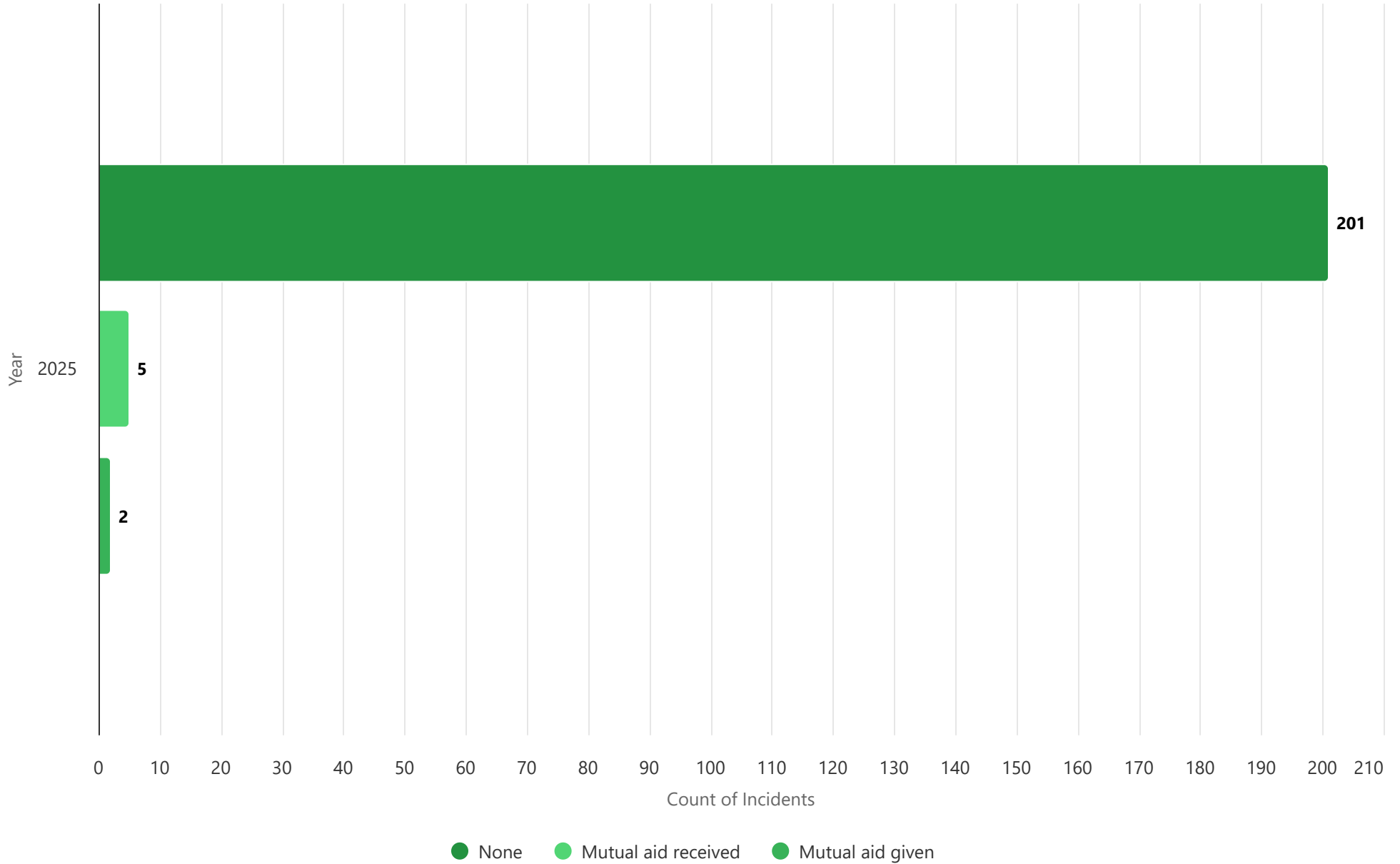

Mutual Aid Given by Incident Type Category

Jan 01, 2024 12:00 AM to Oct 31, 2025 11:59 PM

Incident Type Category	2025										2025		2024		YTD % Change
	Jan	Feb	Mar	Apr	May	Jun	Jul	Aug	Sep	Oct	Grand Total - Current	% of Total Incidents - Current	Grand Total - Previous	% of Total Incidents - Previous	
1 - Fire	0	0	0	0	1	0	2	0	1	0	4	20.00%	4	33.00%	0.00%
3 - Rescue & Emergency Medical Service Incident	0	0	0	0	6	2	2	0	1	1	12	60.00%	2	17.00%	500.00%
5 - Service Call	0	0	0	0	0	0	0	0	0	1	1	5.00%	0	0.00%	N/A
6 - Good Intent Call	0	0	0	2	0	0	1	0	0	0	3	15.00%	6	50.00%	-50.00%
Grand Total	0	0	0	2	7	2	5	0	2	2	20	100.00%	12	100.00%	66.67%

Automatic Aid Given by Incident Type Category

Jan 01, 2024 12:00 AM to Oct 31, 2025 11:59 PM

Incident Type Category	2025										2025		2024		YTD % Change
	Jan	Feb	Mar	Apr	May	Jun	Jul	Aug	Sep	Oct	Grand Total - Current	% of Total Incidents - Current	Grand Total - Previous	% of Total Incidents - Previous	
4 - Hazardous Condition (No Fire)	0	0	0	0	0	0	0	0	0	0	0	N/A	1	3.00%	-100.00%
6 - Good Intent Call	0	0	0	0	0	0	0	0	0	0	0	N/A	23	72.00%	-100.00%
7 - False Alarm & False Call	0	0	0	0	0	0	0	0	0	0	0	N/A	8	25.00%	-100.00%
Grand Total	0	0	0	0	0	0	0	0	0	0	0	100.00%	32	100.00%	-100.00%

Mutual Aid Received by Incident Type Category

Jan 01, 2024 12:00 AM to Oct 31, 2025 11:59 PM

Incident Type Category	2025										2025		2024		YTD % Change
	Jan	Feb	Mar	Apr	May	Jun	Jul	Aug	Sep	Oct	Grand Total - Current	% of Total Incidents - Current	Grand Total - Previous	% of Total Incidents - Previous	
1 - Fire	0	0	0	1	2	0	0	0	0	1	4	10.00%	2	13.00%	100.00%
3 - Rescue & Emergency Medical Service Incident	0	0	0	3	1	5	3	13	2	4	31	76.00%	7	47.00%	342.86%
4 - Hazardous Condition (No Fire)	0	0	0	0	0	0	0	1	0	0	1	2.00%	2	13.00%	-50.00%
5 - Service Call	0	0	0	0	1	0	0	0	0	0	1	2.00%	2	13.00%	-50.00%
6 - Good Intent Call	0	0	0	0	0	0	0	0	0	0	0	0.00%	1	7.00%	-100.00%
7 - False Alarm & False Call	0	0	0	0	0	0	0	2	0	0	2	5.00%	1	7.00%	100.00%
8 - Severe Weather & Natural Disaster	0	0	0	0	0	0	0	2	0	0	2	5.00%	0	0.00%	N/A
Grand Total	0	0	0	4	4	5	3	18	2	5	41	100.00%	15	100.00%	1.73%

Automatic Aid Received by Incident Type Category

Jan 01, 2024 12:00 AM to Oct 31, 2025 11:59 PM

Incident Type Category	2025										2025		2024		YTD % Change
	Jan	Feb	Mar	Apr	May	Jun	Jul	Aug	Sep	Oct	Grand Total - Current	% of Total Incidents - Current	Grand Total - Previous	% of Total Incidents - Previous	
1 - Fire	0	0	0	0	0	0	0	0	0	0	0	N/A	1	20.00%	-100.00%
6 - Good Intent Call	0	0	0	0	0	0	0	0	0	0	0	N/A	1	20.00%	-100.00%
7 - False Alarm & False Call	0	0	0	0	0	0	0	0	0	0	0	N/A	3	60.00%	-100.00%
Grand Total	0	0	0	0	0	0	0	0	0	0	0	100.00%	5	100.00%	-100.00%

Mutual Aid Given by Fire Department Given Aid

Jan 01, 2024 12:00 AM to Oct 31, 2025 11:59 PM

Fire Department	FDID	2025										2025		2024		YTD % Change
		Jan	Feb	Mar	Apr	May	Jun	Jul	Aug	Sep	Oct	Grand Total - Current	% of Total Incidents - Current	Grand Total - Previous	% of Total Incidents - Previous	
Cedarburg Fire Department	45130	0	0	0	0	0	0	1	0	0	0	1	5.00%	1	8.00%	0.00%
City of Waukesha Fire Department	67060	0	0	0	0	0	0	1	0	0	0	1	5.00%	0	0.00%	N/A
Jackson Fire Department	66060	0	0	0	0	1	0	0	0	1	2	4	20.00%	0	0.00%	N/A
Menomonee Falls Fire Department	67030	0	0	0	1	1	0	0	0	1	0	3	15.00%	5	42.00%	-40.00%
Merton Fire Department	67180	0	0	0	0	0	0	0	0	0	0	0	0.00%	1	8.00%	-100.00%
Richfield Fire Department	66100	0	0	0	0	4	1	1	0	0	0	6	30.00%	2	17.00%	200.00%
Southern Ozaukee Fire Department	45140	0	0	0	0	1	1	1	0	0	0	3	15.00%	2	17.00%	50.00%
Sussex Fire Department	67300	0	0	0	0	0	0	1	0	0	0	1	5.00%	0	0.00%	N/A
West Bend Fire Department	66010	0	0	0	0	0	0	0	0	0	0	0	0.00%	1	8.00%	-100.00%
Western Lakes Fire District	67130	0	0	0	1	0	0	0	0	0	0	1	5.00%	0	0.00%	N/A
Grand Total		0	0	0	2	7	2	5	0	2	2	20	100.00%	12	100.00%	66.67%

Automatic Aid Given by Fire Department Given Aid

Jan 01, 2024 12:00 AM to Oct 31, 2025 11:59 PM

Fire Department	FDID	2025										2025		2024		YTD % Change	
		Jan	Feb	Mar	Apr	May	Jun	Jul	Aug	Sep	Oct	Grand Total - Current	% of Total Incidents - Current	Grand Total - Previous	% of Total Incidents - Previous		
Menomonee Falls Fire Department	67030	0	0	0	0	0	0	0	0	0	0	0	0	N/A	32	100.00%	-100.00%
Grand Total		0	0	0	0	0	0	0	0	0	0	0	0	100.00%	32	100.00%	-100.00%

Mutual Aid Received by Fire Department

Jan 01, 2024 12:00 AM to Oct 31, 2025 11:59 PM

Fire Department	2025										2025		2024		YTD % Change
	Jan	Feb	Mar	Apr	May	Jun	Jul	Aug	Sep	Oct	Grand Total - Current	% of Total Incidents - Current	Grand Total - Previous	% of Total Incidents - Previous	
Cedarburg Fire Department	0	0	0	0	1	0	0	1	0	0	2	3.00%	0	N/A	N/A
Hartford Fire Department	0	0	0	0	2	0	0	3	0	1	6	9.00%	0	N/A	N/A
Jackson Fire Department	0	0	0	0	2	0	0	4	0	2	8	12.00%	0	N/A	N/A
Menomonee Falls Fire Department	0	0	0	2	2	2	2	5	2	3	18	26.00%	0	N/A	N/A
Merton Fire Department	0	0	0	0	0	0	0	0	0	1	1	1.00%	0	N/A	N/A
Newburg Fire Department	0	0	0	0	1	0	0	0	0	0	1	1.00%	0	N/A	N/A
Ozaukee Central Fire Department	0	0	0	0	0	0	0	1	0	1	2	3.00%	0	N/A	N/A
Pewaukee Fire Department	0	0	0	0	1	0	0	1	0	1	3	4.00%	0	N/A	N/A
Richfield Fire Department	0	0	0	2	3	1	1	6	0	1	14	21.00%	0	N/A	N/A
Slinger Fire Department	0	0	0	0	0	0	0	1	0	1	2	3.00%	0	N/A	N/A
Southern Ozaukee Fire Department	0	0	0	0	2	2	0	3	0	2	9	13.00%	0	N/A	N/A
West Bend Fire Department	0	0	0	0	1	0	0	0	0	1	2	3.00%	0	N/A	N/A
Grand Total	0	0	0	4	15	5	3	25	2	14	68	100.00%	0	100.00%	N/A

Automatic Aid Received by Fire Department

Jan 01, 2024 12:00 AM to Oct 31, 2025 11:59 PM

Fire Department	2025										2025		2024		YTD % Change	
	Jan	Feb	Mar	Apr	May	Jun	Jul	Aug	Sep	Oct	Grand Total - Current	% of Total Incidents - Current	Grand Total - Previous	% of Total Incidents - Previous		

Incidents by Month

Oct 01, 2025 to Oct 31, 2025

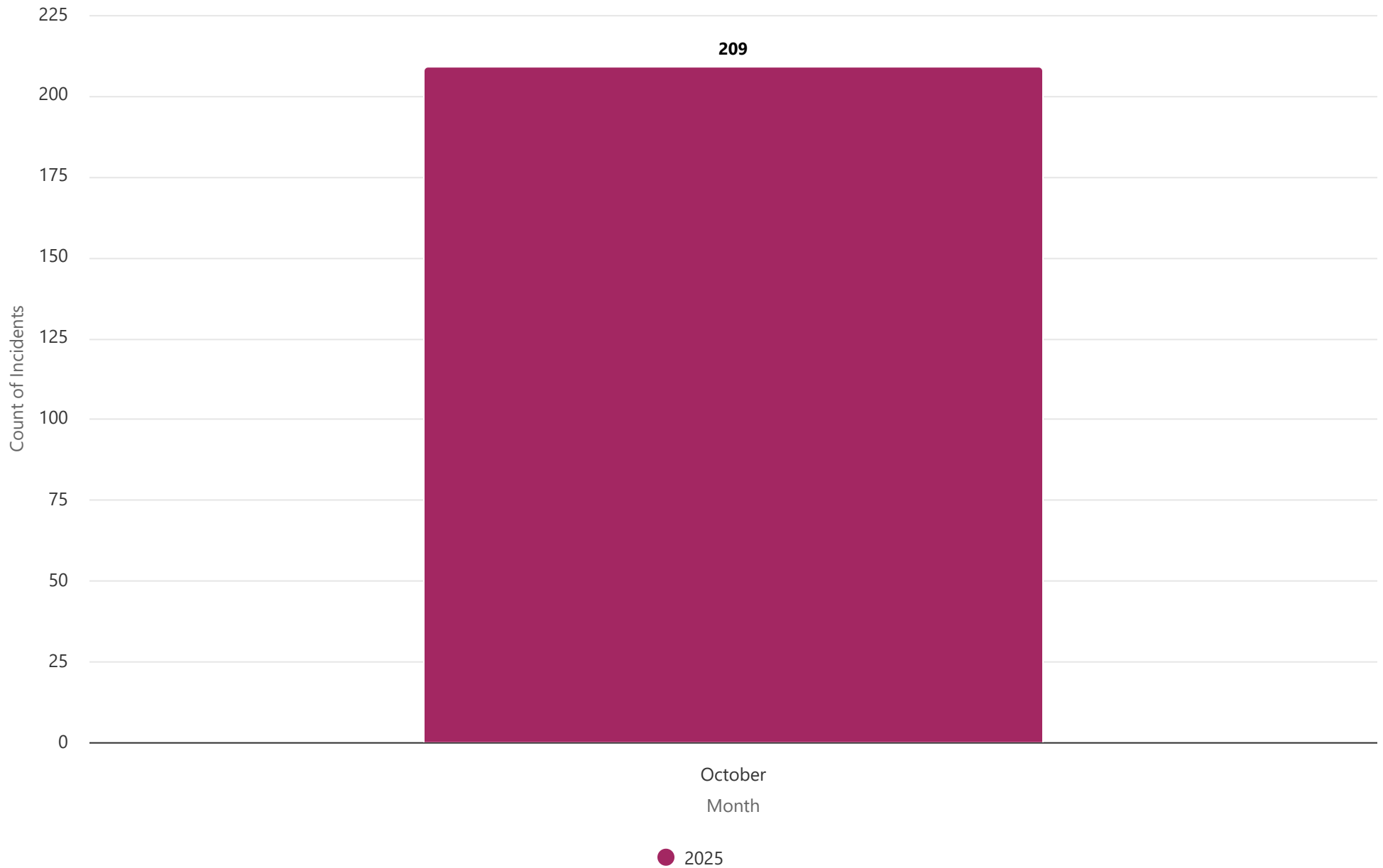

Incidents by Day and Hour

Oct 01, 2025 to Oct 31, 2025

Day of Week	0000	0100	0200	0300	0400	0500	0600	0700	0800	0900	1000	1100	1200	1300	1400	1500	1600	1700	1800	1900	2000	2100	2200	2300
Sunday	1	2	0	0	0	1	1	2	0	0	4	2	1	0	1	0	1	4	0	2	3	0	0	0
Monday	1	0	0	0	0	1	2	0	2	1	1	3	0	2	0	1	1	1	0	3	0	2	1	0
Tuesday	0	0	0	0	0	0	3	1	2	2	1	5	1	0	3	1	1	2	0	0	1	0	0	0
Wednesday	1	0	0	0	1	2	1	2	2	1	2	3	0	4	2	0	1	2	4	1	1	1	1	1
Thursday	2	0	1	0	2	3	1	4	4	4	1	4	5	3	0	2	1	1	2	1	1	3	2	0
Friday	1	1	0	0	0	0	1	0	1	3	4	2	0	5	1	0	3	2	2	1	0	1	0	1
Saturday	1	0	0	0	1	1	0	0	4	0	2	1	1	1	4	1	2	3	3	2	2	0	0	1

Monthly Call Volume Year over Year

Jan 01, 2024 12:00 AM to Oct 31, 2025 11:59 PM

Month Name	2025		2024		YTD % Change
	Grand Total - Current	% of Total Incidents - Current	Grand Total - Previous	% of Total Incidents - Previous	
January	0	0.00%	280	32.00%	-100.00%
February	0	0.00%	197	23.00%	-100.00%
March	1	0.00%	204	23.00%	-99.51%
April	181	13.00%	144	17.00%	25.69%
May	220	15.00%	2	0.00%	10900.00%
June	226	16.00%	8	1.00%	2725.00%
July	205	14.00%	18	2.00%	1038.89%
August	220	15.00%	8	1.00%	2650.00%
September	178	12.00%	7	1.00%	2442.86%
October	209	15.00%	4	0.00%	5125.00%
Grand Total	1,440	100.00%	872	100.00%	65.14%

Property Losses by Month

Oct 01, 2025 to Oct 31, 2025

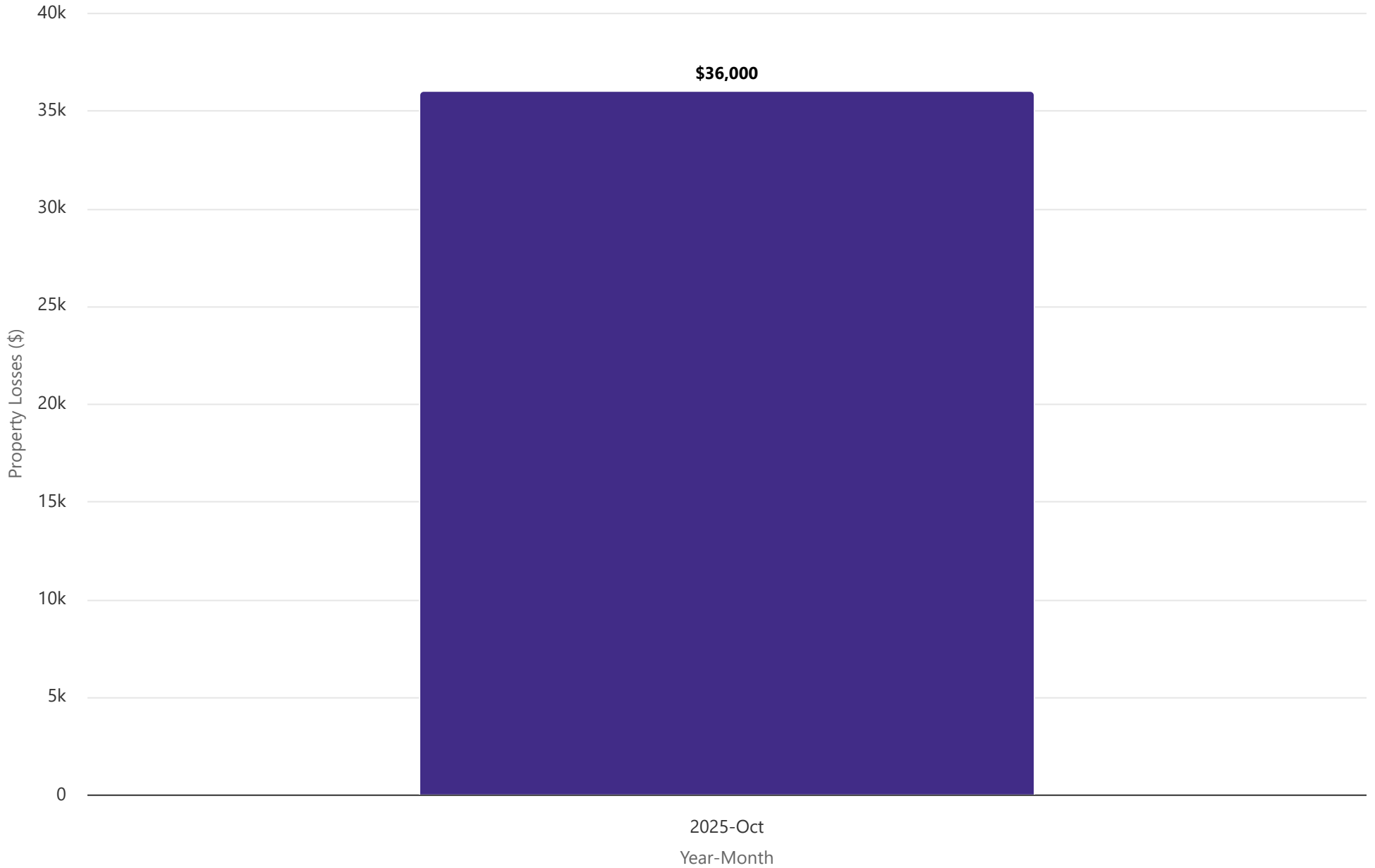

Property Loss Incidents (Top 20)

Oct 01, 2025 to Oct 31, 2025

Agency Name	Incident Date Time	Incident Number	Property Use	Street Number	Street Name	City	State	Postal Code	Property Pre-Incident Value	Property Loss
Germantown Fire Department	10/30/2025 01:45 PM	25.002052	1 or 2 family dwelling	W211 N11788	Hilltop	Germantown	WI	53022	\$30,000	\$30,000
Germantown Fire Department	10/22/2025 05:44 AM	25.001988	Highway or divided highway	(blank)	Hwy 41 NB	Richfield	WI	53076	\$6,000	\$6,000

Firefighter Casualty Summary

Oct 01, 2025 to Oct 31, 2025

Values

There are no results to display

Overlapping Calls and Hours

Oct 01, 2025 12:00 AM to Oct 31, 2025 11:59 PM

Overlapping Calls	Occurrences	% of Occurrences	Hours	% of Hours
No Overlapping Calls	358	86.27%	725	97.46%
Overlapping Calls	57	13.73%	19	2.54%
Totals	415	100.00%	744	100.00%

Expanded Overlapping Calls and Hours

Oct 01, 2025 12:00 AM to Oct 31, 2025 11:59 PM

Overlapping Calls	Occurrences	% of Occurrences	Hours	% of Hours
0 Overlapping Calls	358	86.27%	725	97.46%
1 Overlapping Call	51	12.29%	18	2.46%
2 Overlapping Calls	5	1.20%	1	0.07%
3 Overlapping Calls	1	0.24%	0	0.02%
Totals	415	100.00%	744	100.00%

Calls in Progress

Oct 01, 2025 12:00 AM to Oct 31, 2025 11:59 PM

Calls in Progress	Occurrences	% of Occurrences	Hours	% of Hours
0 Calls In Progress	156	37.59%	612	82.21%
1 Call In Progress	202	48.67%	113	15.25%
2 Calls In Progress	51	12.29%	18	2.46%
3 Calls In Progress	5	1.20%	1	0.07%
4 Calls In Progress	1	0.24%	0	0.02%
Totals	415	100.00%	744	100.00%

Overlapping Calls

Oct 01, 2025 12:00 AM to Oct 31, 2025 11:59 PM

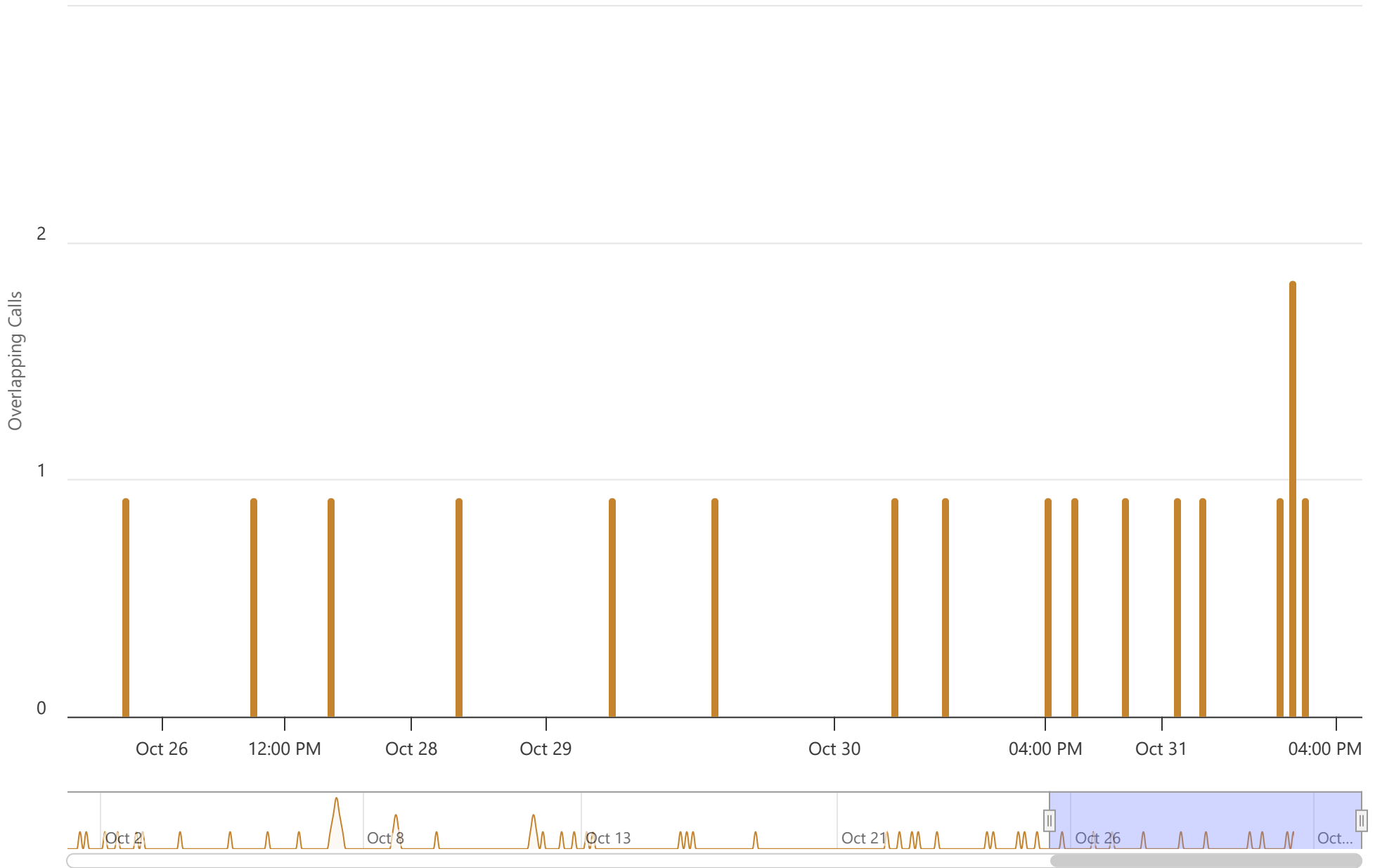

2025 POLICE SGT OT

	OT HRS	OT PAID	COMP HRS	OT COMP
JAN	112.50	\$ 8,370.81	7.75	\$576.66
FEB	83.00	6,175.80	23.00	1,711.37
MAR	51.00	3,794.77	46.25	3,441.33
APR	58.00	4,315.62	27.25	2,027.60
MAY	77.00	5,729.35	36.75	2,734.46
JUN	101.50	7,552.33	48.00	3,571.55
JUL	83.50	6,213.00	30.00	2,232.22
AUG	79.50	5,915.37	17.75	1,320.73
SEP	58.75	4,371.42	47.75	3,552.94
OCT	48.25	1,878.78	18.75	1,246.32
NOV	60.00	4,464.43	37.00	2,753.07
DEC				
	813.00	\$ 58,781.69	340.25	\$25,168.24

2025 POLICE UNION OT

	OT HRS	OT PAID	COMP HRS	OT COMP
JAN	99.00	\$ 6,650.67	77.50	\$5,075.37
FEB	95.25	6,234.14	82.25	5,499.99
MAR	129.50	8,599.47	74.00	4,822.09
APR	229.50	15,066.37	99.00	6,610.65
MAY	258.50	16,992.72	100.50	7,057.41
JUN	363.50	24,150.12	199.00	12,228.79
JUL	404.75	26,292.02	223.50	14,499.44
AUG	204.50	12,843.64	117.50	7,752.56
SEP	164.50	9,786.32	97.25	6,423.61
OCT	219.25	13,667.49	80.00	5,183.08
NOV	239.00	15,315.73	74.75	4,636.98
DEC				
	2,407.25	\$ 155,598.67	1,225.25	\$ 79,789.96

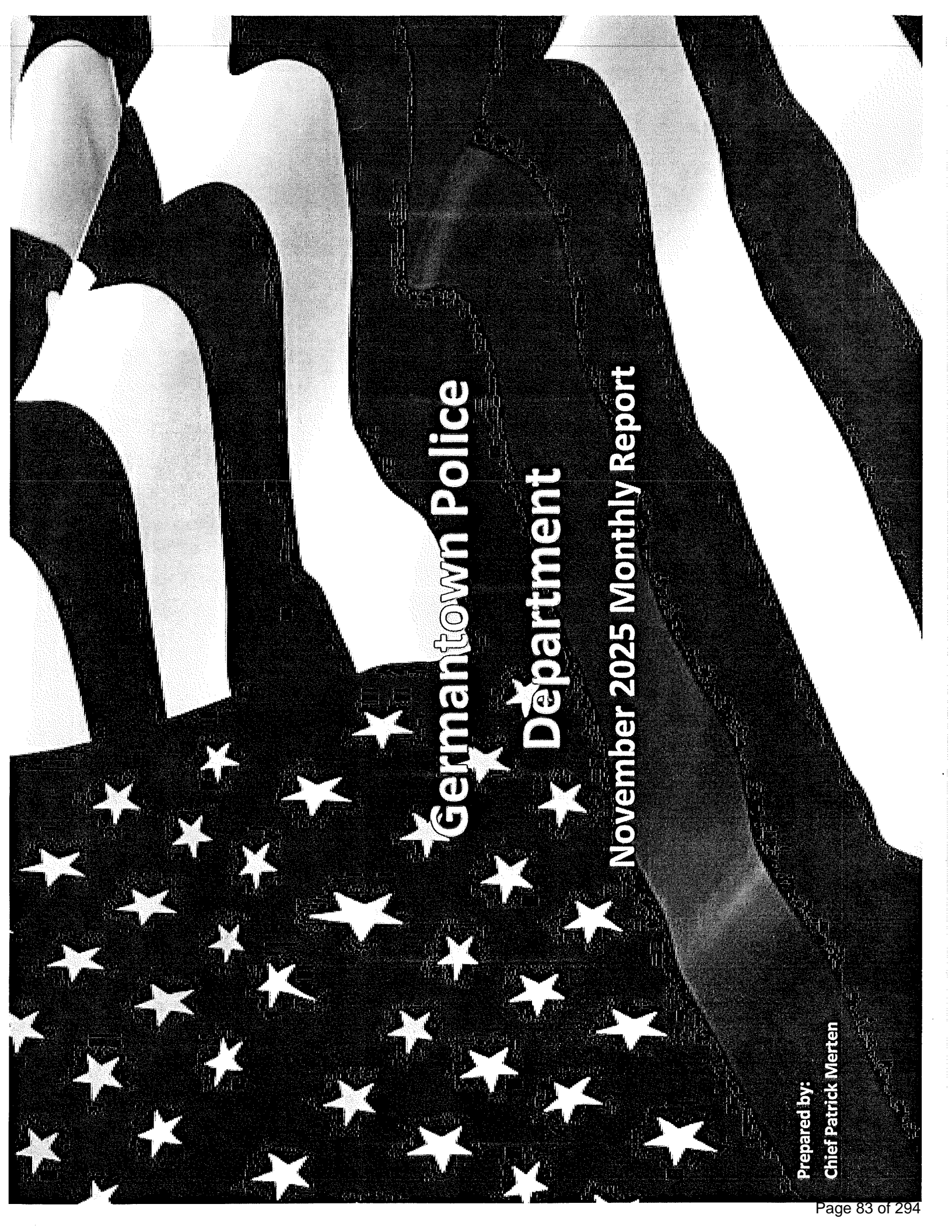
The background of the page is a stylized, high-contrast black and white representation of the American flag. The stars are depicted as white, five-pointed shapes on a black field, and the stripes are represented by thick, wavy black and white bands.

**Germantown Police
Department**

November 2025 Monthly Report

**Prepared by:
Chief Patrick Merten**



Monthly Activity Overview Report

Printed On: 12/30/25 07:27

For Reporting Period: **11/01/2025 - 11/30/2025**

Patrol Area: **NULL,CN,CS,N,R,S**

NOTE: This report cannot be run based on individual officer - it is based on unique Incident. This report is for specific overview purposes & counts. For individual Officer activities, please refer to Officer Activity Count reports.

Calls

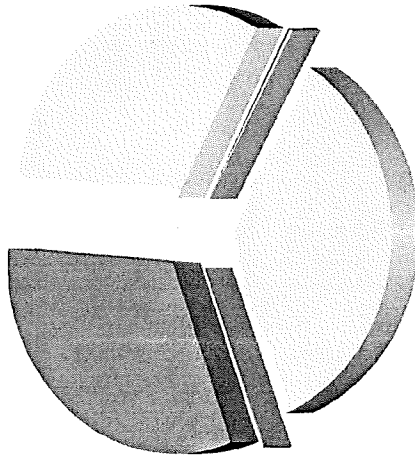

Mail 0.08%
 Officer Initiated 35.78%
 Other 0.20%
 Phone - Cell/Landline etc 31.80%
 Walk In 0.16%
 Walk-In 0.16%

Reports

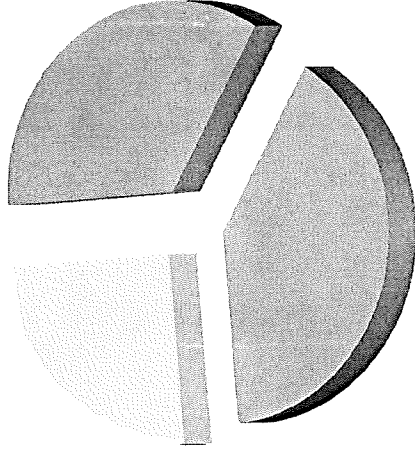

Incident 40.21%
 Property 25.43%
 Supplemental 34.36%

Reports are selected based upon Dttm report is written and selected if Dttm falls within date range above-specified.

Call Type	0001 Hours	0800 Hours	1601 Hours	Total
Mail	0	2	0	2
Officer Initiated	323	349	201	873
Other	0	5	0	5
Phone	135	350	291	776
Phone - Cell/Landline etc	135	350	291	776
Walk In	1	2	1	4
Walk-In	1	2	1	4
Total	459	708	493	1,660

Report Type	0001 Hours	0800 Hours	1601 Hours	Total
Incident	43	34	40	117
Property	25	23	26	74
Supplemental	29	36	35	100
Total	97	93	101	291



Monthly Activity Overview Report

Printed On: 12/30/25 07:27

For Reporting Period: **11/01/2025 - 11/30/2025**

Patrol Area: **NULL,CN,CS,N,R,S**

Arrests

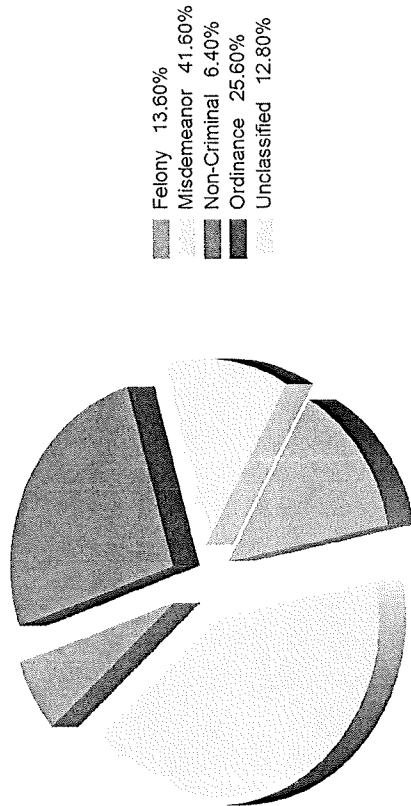

Arrests are selected based upon the charge type. Therefore if an arrest was made wherein three charges with different types are noted, the arrest will count under Each charge type.

	0001	0800	1601	Total
Felony	9	6	2	17
Misdemeanor	19	20	13	52
Non-Criminal	4	3	1	8
Ordinance	7	16	9	32
Unclassified	2	8	6	16
Total	41	53	31	125
	Hours	Hours	Hours	Hours

Citations

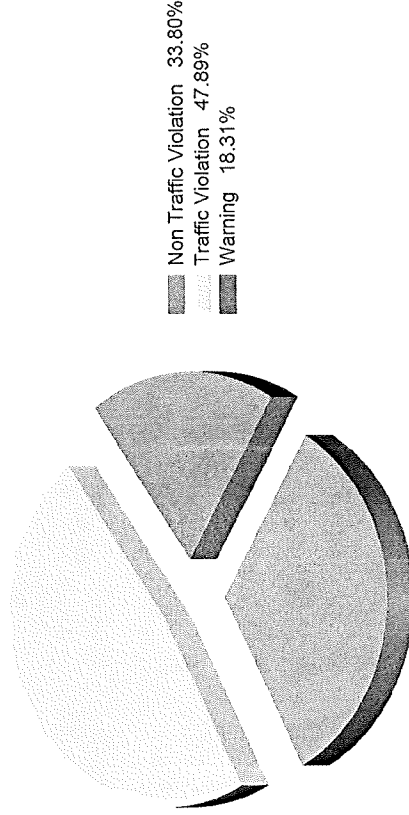

Citations are counted by Citation Type alone.

	0001	0800	1601	Total
Non Traffic Violation	10	12	2	24
Traffic Violation	12	16	6	34
Warning	3	9	1	13
Total	25	37	9	71
	Hours	Hours	Hours	Hours



Monthly Activity Overview Report

Printed On: 12/30/25 07:27

For Reporting Period: **11/01/2025 - 11/30/2025**

Patrol Area: **NULL,CN,CS,N,R,S**

Field Interview Stops

No Data Available

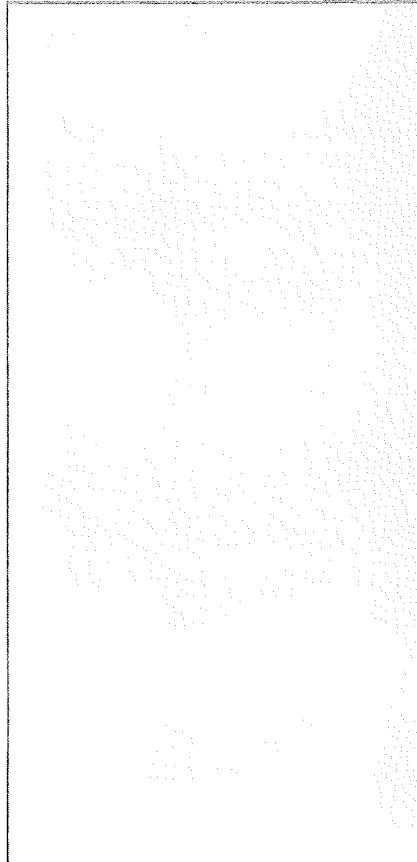

Crash

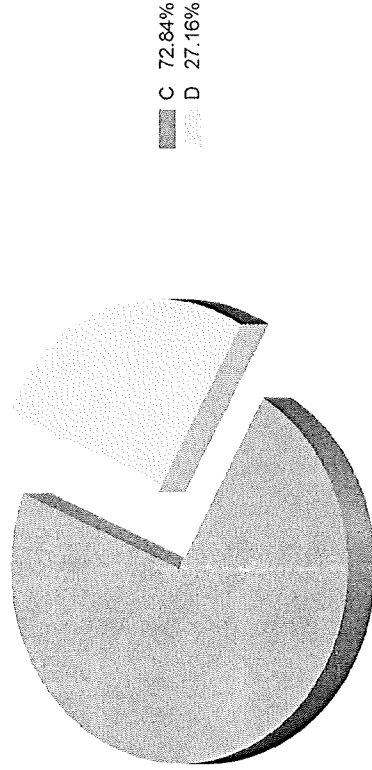

Field Interview Stops are counted by reason for stop.

Total	0
--------------	----------

Crashes are counted by Crash type alone.

Crash	0001 Hours	0800 Hours	0800 Hours	1601 Hours	1600 Hours	2400 Hours	Total
C	18	11	7	30	26	22	81
D					4	11	22
Total	18	11	7	30	26	22	81



Monthly Case Overview Report

Printed On: 12/30/25 07:28

Reporting Period: 11/01/2025 - 11/30/2025

Village of Germantown - 1182

	Total	Total
Abandoned Vehicles		1
Accident Investigation		1
Accident-Car Kill Deer		21
Accident-Traffic-Hit and Run		5
Accident-Traffic-PDO		43
Accident-Traffic-Personal Injury		7
Administrative		21
Aggravated Assault		1
Ambulance Request		1
Animal Complaint - Animal Neglect		1
Assault		1
Assist Other Law Enforcement Agency		2
Assist PD		1
Bail Jumping - Personal Recognizance		3
Burglary		1
Carrying a Concealed Weapon		1
Chapter 51		1
Cocaine - Possession		2
Contempt of Court		1
Criminal Damage to Property - Business		1
Criminal Damage to Property - Public		1
DC/Disorderly Conduct		8
DC/Disorderly Conduct - Fighting		10
DC/Disorderly Conduct - Noise/Nuisance		2
Death Investigation		1
Disorderly Conduct		1
Driving/Operating Under the Influence - Alcohol		3
Extortion - Threaten to Injure Reputation		1
Family Trouble		1
Fire Investigation		2
Found/Recovered - Property		1
Fraud - Impersonate		4
Fraud - Swindle		1
Fraudulent Activities		2
Health or Safety		3
Hit and Run/Leaving the Scene of a Crash		1
Lost or Found Property		6
Lost Property		1
Marijuana - Possession		4



Monthly Case Overview Report

Printed On: 12/30/25 07:28

Reporting Period: 11/01/2025 - 11/30/2025

Mental Inc/Emerg Detention/Detox	2
Municipal Violation	1
Narcotic Equipment (Paraphernalia) - Possession	1
Probation Violation	1
Resisting an Officer - Simple Physical Assault	1
Sale of Stolen Property	1
Sexual Assault	1
Simple Assault	1
Synthetic Narcotic - Possession	1
Theft - All Others >=\$200	3
Theft - Auto Parts >=\$200	1
Theft - From Auto \$50-\$199	1
Theft - Retail \$50-\$199	2
Theft - Retail <\$50	3
Theft - Retail >=\$200	2
Traffic Offense	10
Traffic Stop	3
Truancy	4
Vandalism-Damage to Property	1
Vehicle Traffic	1
Warrant Pickup - Other Agency	1
Weapons Offense	1
Welfare Check	1



Citations by Statutes

Printed On: 12/30/25 07:30

Village of Germantown

Reporting Period: 11/01/2025 - 11/30/2025

This report contains all citations.

	Total	Non Traffic Violation	Traffic Violation	Warning
12.02(11) - Animals at Large - 2nd	1	1	0	0
341.03(1) - Operate Unregistered Vehicle	2	0	1	1
341.04(1) - Non-Registration of Vehicle	11	0	3	8
341.15(1m)(a) - Fail/Attach Rear Regis. Decal	1	0	0	1
343.05(3)(a) - Operate w/o Valid License	10	0	10	0
343.44(1)(a) - Operating While Suspended	5	0	5	0
343.44(1)(b) - Operate Motor Vehicle While Revoked - 3rd Offense	1	0	1	0
343.44(1)(b) - Operating While Revoked	2	0	2	0
344.62(1) - Operate Motor Vehicle w/o Insurance	3	0	2	1
346.04(3) - Flee/Elude Officer	1	0	1	0
346.14(1m) - Automobile Following Too Closely	2	0	2	0
346.18(3) - FYR - From Stop Sign	2	0	2	0
346.37(1)(c)1 - Violate Red Traffic Signal	2	0	2	0
346.46(1) - Fail Stop At Stop Sign	2	0	1	1
346.57(2) - Failure to Keep Vehicle Under Control	1	0	1	0
346.57(5) - Exceed Speed Zones/Post Limits	1	0	0	1
346.63(1)(a) - OAWI Alcohol - Municipal	3	0	3	0
346.63(1)(b) - Operating with PAC .15 or >	1	0	1	0
346.68 - Hit and run unattended vehicle	1	0	1	0
346.69 - Hit and Run Prop	1	0	1	0
346.70(1) - Failure to Notify Police of Accident (Operator)	1	0	1	0
347.413(1) - IID Tampering/Fail to Install/Violate Court Order	2	0	2	0
9.01(82) - 3390901307	9	9	0	0
9.04(1) - 3390901267	1	1	0	0
9.041 - 3390901152	1	1	0	0
9.045(3) - Forgery - 1st	2	2	0	0
9.047(1) - 3390901074	1	1	0	0
9.047(1) - 3390901077	1	1	0	0
9.047(1) - 3390901078	1	1	0	0
9.07 - 3390900547	1	1	0	0
9.1 - Underage Possess/Consume 17-20 - 1st	1	1	0	0
GV9.01(63)A - SHOPLIFTING - TAKE MERCHANDISE	1	1	0	0
GV9.01(82) - DISORDERLY CONDUCT	3	3	0	0
GV9.047(1) - 118.163(1)(d) TRUANCY (JUVENILE)-2ND OFF	1	1	0	0
Total	79	24	42	13

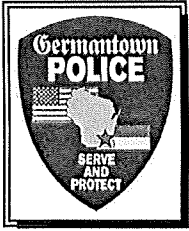

Village of Germantown Police

| | Phone: () -

Monthly Calls for Service

Tuesday, December 30, 2025

7:32:01 am

** For official use only **

Column1: 11/01/25 - 11/30/25

Column2: 11/01/24 - 11/30/24

Village of Germantown

	2020	2019	%Change
1046 - Disabled Vehicle	25	32	-21.88%
ABAN - Abandoned Vehicle	4	4	0.00%
ACHR - Accident-Traffic-Hit and Run	10	17	-41.18%
ACPD - Accident-Traffic-Property Damage Only	57	49	16.33%
ACPI - Accident-Traffic-Personal Injury	8	10	-20.00%
ACVD - Accident-Traffic-Vehicle in Ditch	11	14	-21.43%
ALMA - Alarm-All	31	38	-18.42%
ALMF - Fire-Alarm	18	9	100.00%
ALMM - Alarm-Carbon Monoxide	4	1	300.00%
ALPR - Automatic License Plate Recognition	3	3	0.00%
AMLC - Animal Complaint (Excludes bites)	19	18	5.56%
ASLO - Assist-Lockout	14	5	180.00%
ASLT - Assault (Aggravated&non-aggravated)	1	0	-
ASOT - Assistance-All Others	44	20	120.00%
ASPD - Assistance-Other Law Enforcement Ager	35	26	34.62%
BAIL - Bail Jumping/Bond Violations	2	0	-
BURG - Burglary	0	2	-
CHLD - Child Abuse	0	2	-
CIVM - Civil Matter	4	7	-42.86%
CKD - Accident-Traffic-Car Kill Deer	24	15	60.00%
CSAM - Child Sexual Abuse Material	0	1	-
DARE - Teaching DARE Class within the school	0	2	-
DC - Disorderly Conduct	29	40	-27.50%
DINV - Death Investigation	1	2	-50.00%
DOM - Domestic	4	1	300.00%
DRON - Drone	3	1	200.00%
DRUG - Drugs-Violation-Controlled Substance	2	2	0.00%
E911 - E911 Abandoned/False Calls	64	52	23.08%
ESCT - Escort/Bank Run, etc	0	1	-
ESPR - Prisoner Escort-Security	1	0	-
EXTO - Extortion	1	0	-
FAMT - Family Trouble Excludes Domestic	13	3	333.33%
FING - Fingerprinting	0	3	-
FIRG - Fire-Grassfire	3	0	-

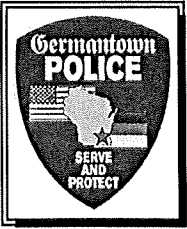

Village of Germantown Police

| , | Phone: () -

Tuesday, December 30, 2025

7:32:01 am

** For official use only **

Monthly Calls for Service

Column1: 11/01/25 - 11/30/25

Column2: 11/01/24 - 11/30/24

FIRO - Fire-All Other	13	11	18.18%
FRAU - Fraudulent Activities	7	12	-41.67%
FRWK - Fireworks	0	1	-
FU - Follow up	0	1	-
HARA - Harassment (Includes phone calls)	2	4	-50.00%
HAZ - Hazardous Conditions-Road Hazards	24	19	26.32%
IDEN - Identity Theft	1	0	-
INF - Informational report	7	12	-41.67%
JUV - Juvenile-Status (Includes Runaway)	6	3	100.00%
K9DRUG - K9 Drug Investigations	4	0	-
K9OTHR - K9 Other	5	0	-
K9SRCH - K9 Searches	2	0	-
LIT - Littering	1	2	-50.00%
LOST - Lost Property	2	1	100.00%
MISP - Missing Person	0	1	-
MNTL - Mental-Walkaway/Incapacited/Etc	4	4	0.00%
MUNI - Municipal Ordinance Investigation	2	8	-75.00%
NOISE - Noise Complaints	4	0	-
OPEN - Open Door	0	2	-
PARK - Parking Violation	7	12	-41.67%
PKCK - Park Check	0	163	-
PR - Public Relations	200	161	24.22%
PROP - Property Check	210	237	-11.39%
RCOV - Recovered Property	8	7	14.29%
REPO - Repossessions	3	0	-
RESC - Ambulance Request	144	148	-2.70%
SBUS - School Bus Violation	0	1	-
SCHO - School Grounds Visit	26	58	-55.17%
SEXA - Sexual Assault	1	1	0.00%
SEXO - Sex Offense	0	1	-
SOLICIT - Soliciting	0	4	-
SUSP - Suspicious Person/Vehicle/Situation	40	29	37.93%
TE - Traffic Enforcement	41	38	7.89%
THFT - Larceny (Theft)	18	26	-30.77%
TOBC - Tobacco Violations (All).	0	2	-
TR - Traffic Request	0	4	-
TRAF - Traffic Stop	315	354	-11.02%

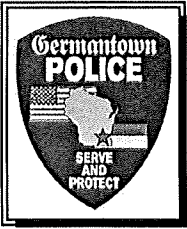

Village of Germantown Police

| , | Phone: () -

Monthly Calls for Service

Tuesday, December 30, 2025

7:32:01 am

** For official use only **

Column1: 11/01/25 - 11/30/25

Column2: 11/01/24 - 11/30/24

TRES - Trespassing/Prowler	4	1	300.00%
TRO - Restraining Order/Injunction Violation	3	0	-
TRUA - Truancy	4	0	-
TVRN - Tavern Check	2	14	-85.71%
VAND - Vandalism-Damage to Property	6	9	-33.33%
VEHT - Vehicle Traffic	65	36	80.56%
WEAP - Weapons Offense	6	7	-14.29%
WELF - Welfare Check	32	22	45.45%
WRNT - Warrant Service/Attempt	6	9	-33.33%
Total	1,660	1,805	



Arrests by Statute Report

Printed On: 12/30/25 07:34

Reporting Period: 11/01/25 - 11/30/25

This report contains all arrest charges.

	Total	Felony	Misdemeanor	Non-Criminal	Ordinance	Unclassified
343.05(3)(a) - Operate without Valid License and Cause Injury to Another Person	1				1	
343.05(3)(a) - Operating Without a License - 2nd Offense within 3 Years	5		5			
343.05(3)(a) - Operating Without a License - 3rd or Subsequent Offense within 3 Years	1		1			
343.44(1)(b) - Operate Motor Vehicle While Revoked - Revocation due to Alcohol/Controlled Substance/Refusal	1		1			
343.44(1)(b) - Operating While Revoked	3		3			
346.04(3) - Operator Flee/Elude Officer	1	1				
346.63(1)(a) - OAWI 1st Offense	1			1		
346.63(1)(a) - Operating While Intoxicated - 3rd Offense	2		2			
346.63(1)(a) - Operating While Intoxicated - 4th Offense	1	1				
346.63(1)(b) - Operating With Prohibited Alcohol Concentration - 3rd Offense	1		1			
346.67(1) - Hit and Run-Injury	1		1			
346.69 - Hit and Run Prop Adj to Highway	1			1		
347.413(1) - IID Tampering/Fail to Install/Violate Court Order	1		1			
347.413(1) - IID Tampering/Failure to Install	1		1			
347.413(1) - IID Tampering/Failure to Install (2nd+)	1		1			
450.11(7)(h) - Possess/Illegally Obtained Prescription	1		1			
51.15(1) - Emergency Detention	2			2		
813.12(8)(a) - Knowingly Violate a Domestic Abuse Order	2		2			
9011 - Warrant Pickup - Probation & Parole	1				1	
90Z4 - Warrant-Other Department Pickup	3			3		
940.30 - False Imprisonment	1	1				
940.60(1) - Battery-Whoever causes bodily harm to another by an act done with intent to cause bodily harm to that person or another without the consent of the person	2		2			
941.20(1)(b) - Possession of a Firearm While Intoxicated	1		1			
941.23(2) - Carrying Concealed Weapon	1		1			
941.29(1m)(a) - Possession of a Firearm by a Felon	1	1				
941.30(2) - 2nd-Degree Recklessly Endangering Safety	1	1				
943.01(1) - Criminal Damage to Property	1		1			
943.201(2)(b) - Use any personal identifying information to avoid civil or criminal process or penalty	1	1				
943.34(1)(a) - Receiving Stolen Property (<=\$2,500)	1		1			
943.50(1m)(b) - Retail Theft	1		1			
943.50(1m)(b) - Retail Theft - Intentionally Take - (<=\$500)(UCR \$50-\$199)	2		2			
943.50(4)(bf) - Retail Theft more than \$500 but less than \$5,000.	2	2				
946.41(1) - Resisting or Obstructing an Officer	6		6			
946.49(1)(a) - Bail Jumping-Misdemeanor	4		4			
946.49(1)(b) - Bail Jumping-Felony	1	1				



Arrests by Statute Report

Printed On: 12/30/25 07:34

Reporting Period: 11/01/25 - 11/30/25

This report contains all arrest charges.

	Total	Felony	Misdemeanor	Non-Criminal	Ordinance	Unclassified
947.01(1) - Disorderly Conduct	21		7		14	
947.019(1) - Terrorist Threats	1	1				
961.41(1m)(cm) - Poss/Intent Manuf/Del. Coçaine (>15-40g)	1	1				
961.41(3g)(am) - Possession of Narcotic Drugs	2	2				
961.41(3g)(c) - Possession of Cocaine	1		1			
961.41(3g)(c) - Possession of Cocaine (2nd +)	1	1				
961.41(3g)(e) - Possession of Marijuana/THC	3		3			
961.41(3g)(e) - Possession of THC (Tetrahydrocannabinols) - (2nd and subsequent)	2	2				
961.41(3g)(g) - Possess Methamphetamine	1	1				
961.573(1) - Possess Drug Paraphernalia	2		2			
968.075 - Domestic Abuse Incident	2					2
973.10 - Probation/Parole Hold	1			1		
ADMIN - Warrant - Warrant	11					11
GV12.02(11) - UNDERAGE DRINKING-POSSESS-14-16	1				1	
GV9.01(63)A - SHOPLIFTING - TAKE MERCHANDISE	3				3	
GV9.01(75) - Resisting/Obstructing Officer	1				1	
GV9.04(1) - 961.41(3g)(e)MARIJUANA POSSESSION PROHIBITED	1				1	
GV9.041 - 254.92 TOB\NICOTINE\VAPE PROD PROHIB AGE 12-17 1ST	1				1	
GV9.045(3) - 961.573(1) POSSESSION OF DRUG PARAPHERNALIA	2				2	
GV9.047(1) - 118.163(1)(b) HABITUAL TRUANCY (ADULT)	1				1	
GV9.047(1) - 118.163(1)(b) HABITUAL TRUANCY (ADULT)-2ND OFF	1				1	
GV9.047(1) - 118.163(1)(b) HABITUAL TRUANCY (JUVENILE)	1				1	
GV9.047(1) - 118.163(1)(d) TRUANCY (JUVENILE)-2ND OFF	1				1	
GV9.07 - NOISE DISTURBANCES PROHIBITED	2				2	
GV9.1 - ANIMALS OR POULTRY RUNNING AT LARGE	1				1	
PPHOLD - Probation and Parole Hold	3					3
Total	125	17	52	8	32	16



Call Simple Lists

Printed On: 12/30/25 07:35

Village of Germantown

Call#	Reported Date	CAD CFS	Location	Common Name	Disp	Unit#	Officer(s)
25-019269	11/30/25 19:07	Public Relations	N112W15800 Mequon Rd,6;GV	Subway Vgtn	NRPT	735	JRS097
25-019257	11/30/25 11:12	Public Relations	W164N11233 Squire Dr;GV	Speedway GV	NRPT	737	DJP083
25-019252	11/30/25 07:50	Public Relations	N112W18741 Mequon Rd;GV	Kwik Trip GV	NRPT	712	ZAS089
25-019251	11/30/25 07:50	Public Relations	N112W18741 Mequon Rd;GV	Kwik Trip GV	NRPT	750	AML9130
25-019250	11/30/25 07:44	Public Relations	N112W16510 Mequon Rd,A;GV	Starbucks VGTN - Mequon Rd.	NRPT	733	MMO119
25-019221	11/29/25 18:22	Public Relations	W164N11233 Squire Dr;GV	Speedway GV	NRPT	747	BPD9058
25-019217	11/29/25 16:14	Public Relations	W164N11233 Squire Dr;GV	Speedway GV	NRPT	748	TSW9112
25-019208	11/29/25 08:26	Public Relations	N112W16510 Mequon Rd,A;GV	Starbucks VGTN - Mequon Rd.	NRPT	733	MMO119
25-019207	11/29/25 08:12	Public Relations	N128W21760 Holy Hill Rd,A;GV	Holy Hill Shell	NRPT	737	DJP083
25-019197	11/29/25 03:32	Public Relations	N119W15016 Ivy Ln;GV		NRPT	746	TJN9088
25-019184	11/28/25 19:57	Public Relations	N112W16040 Mequon Rd;GV	Roberts Frozen Custard	NRPT	735	JRS097
25-019167	11/28/25 15:02	Public Relations	N96W17950 County Line Rd;GV	Starbucks VGTN - County Line	NRPT	741	DPK0106
25-019158	11/28/25 12:56	Public Relations	W178N9653 Riversbend La;GV	Speedway GV	NRPT	736	JLS084
25-019154	11/28/25 11:24	Public Relations	W190N9855 Appleton Av,STORE;GV	Walmart VGTN	NRPT	736	JLS084
25-019142	11/28/25 08:47	Public Relations	N96W18200 County Line Rd;GV	Fleet Farm GV	NRPT	736	JLS084
25-019139	11/28/25 07:25	Public Relations	W186N9754 Appleton Av;GV	Menards Vgtn	NRPT	736	JLS084
25-019137	11/28/25 06:45	Public Relations	N112W16510 Mequon Rd,A;GV	Starbucks VGTN - Mequon Rd.	NRPT	736	JLS084
25-019101	11/26/25 21:13	Public Relations	W164N11233 Squire Dr;GV	Speedway GV	NRPT	747	BPD9058
25-019100	11/26/25 19:26	Public Relations	N96W18200 County Line Rd;GV	Fleet Farm GV	NRPT	721	RPB092
25-019066	11/26/25 11:53	Public Relations	W182N9606 Appleton Av,102;GV	Fedex Kinkos Vgtn	NRPT	742	AWD0105
25-019051	11/26/25 06:48	Public Relations	N112W16510 Mequon Rd,A;GV	Starbucks VGTN - Mequon Rd.	NRPT	736	JLS084
25-019048	11/26/25 02:33	Public Relations	W178N9653 Riversbend La;GV	Speedway GV	NRPT	737	DJP083
25-019008	11/25/25 07:26	Public Relations	W204N11968 Goldendale Rd;GV	St. Boniface School St Boniface Church	NRPT	736	JLS084
25-019005	11/25/25 06:50	Public Relations	W180N11501 River La;GV	Germantown High School	NRPT	736	JLS084
25-019003	11/25/25 02:40	Public Relations	N112W18741 Mequon Rd;GV	Kwik Trip GV	NRPT	737	DJP083



Call Simple Lists

Printed On: 12/30/25 07:35

Call#	Reported Date	CAD CFS	Location	Common Name	Disp	Unit#	Officer(s)
25-018978	11/24/25 11:45	Public Relations	N112W18741 Mequon Rd;GV	Kwik Trip GV	NRPT	707	JR098
25-018970	11/24/25 08:41	Public Relations	W154N11492 Fond Du Lac Av;GV	Macarthur Elementary School	NRPT	737	DJP083
25-018969	11/24/25 08:03	Public Relations	W159N9939 Butternut Rd;GV	County Line School	NRPT	750	AML9130
25-018967	11/24/25 07:42	Public Relations	N128W21760 Holy Hill Rd;A;GV	Holy Hill Shell	NRPT	737	DJP083
25-018966	11/24/25 07:32	Public Relations	N108W14290 Bel Aire La;GV	Bethlehem Lutheran Church	NRPT	750	AML9130
25-018964	11/24/25 07:18	Public Relations	W204N11968 Goldendale Rd;GV	St. Boniface School St Boniface Church	NRPT	733	MMO119
25-018963	11/24/25 06:56	Public Relations	N118W15860 Williams Dr;GV	Kennedy Middle School	NRPT	737	DJP083
25-018962	11/24/25 06:54	Public Relations	W180N11501 River La;GV	Germantown High School	NRPT	733	MMO119
25-018949	11/23/25 23:32	Public Relations	N112W18741 Mequon Rd;GV	Kwik Trip GV	NRPT	743	JAR0107
25-018942	11/23/25 18:33	Public Relations	W187N12793 Fond Du Lac Av;GV	Stags Tavern	NRPT	741	DPK0106
25-018928	11/23/25 09:53	Public Relations	W180N11501 River La;GV	Germantown High School	NRPT	721	RPB092
25-018927	11/23/25 09:51	Public Relations	N104W14181 Donges Bay Rd;GV	St John United Church Of Christ	NRPT	733	MMO119
25-018926	11/23/25 09:39	Public Relations	W164N11325 Squire Dr;GV	Life Church	NRPT	733	MMO119
25-018925	11/23/25 09:21	Public Relations	W190N10862 Commerce Cir,BLDG;GV	Best Western VGTN	NRPT	737	DJP083
25-018923	11/23/25 09:00	Public Relations	N112W16282 Mequon Rd;GV	Smoke World Vape	NRPT	743	JAR0107
25-018922	11/23/25 08:22	Public Relations	W180N11501 River La;GV	Germantown High School	NRPT	737	DJP083
25-018921	11/23/25 08:20	Public Relations	N112W16510 Mequon Rd;A;GV	Starbucks VGTN - Mequon Rd.	NRPT	733	MMO119
25-018920	11/23/25 08:15	Public Relations	W164N11233 Squire Dr;GV	Speedway GV	NRPT	737	DJP083
25-018915	11/23/25 01:21	Public Relations	N112W18741 Mequon Rd;GV	Kwik Trip GV	NRPT	743	JAR0107
25-018899	11/22/25 19:57	Public Relations	N112W18741 Mequon Rd;GV	Kwik Trip GV	NRPT	735	JRS097
25-018859	11/22/25 06:37	Public Relations	N112W16510 Mequon Rd;A;GV	Starbucks VGTN - Mequon Rd.	NRPT	733	MMO119
25-018855	11/22/25 01:34	Public Relations	N112W18741 Mequon Rd;GV	Kwik Trip GV	NRPT	744	ALC9032
25-018805	11/21/25 09:23	Public Relations	W204N11968 Goldendale Rd;GV	St. Boniface School St Boniface Church	NRPT	733	MMO119
25-018803	11/21/25 09:15	Public Relations	W180N11501 River La;GV	Germantown High School	NRPT	733	MMO119



Call Simple Lists

Printed On: 12/30/25 07:35

Call#	Reported Date	CAD CFS	Location	Common Name	Disp	Unit#	Officer(s)
25-018802	11/21/25 09:15	Public Relations	3294 Willow Creek Rd;RV	Amy Belle School	NRPT	730	TEO138
25-018801	11/21/25 09:02	Public Relations	W154N11492 Fond Du Lac Av;GV	Macarthur Elementary School	NRPT	750	AML9130
25-018799	11/21/25 08:21	Public Relations	W159N9939 Butternut Rd;GV	County Line School	NRPT	731	KCL088
25-018798	11/21/25 07:58	Public Relations	W159N9939 Butternut Rd;GV	County Line School	NRPT	736	JLS084
25-018797	11/21/25 07:24	Public Relations	N108W14290 Bel Aire La;GV	Bethlehem Lutheran Church	NRPT	736	JLS084
25-018770	11/20/25 14:04	Public Relations	N96W17490 County Line Rd;GV	Super 8	NRPT	742	AWD0105
25-018762	11/20/25 10:36	Public Relations	W154N11492 Fond Du Lac Av;GV	Macarthur Elementary School	NRPT	730	TEO138
25-018759	11/20/25 10:17	Public Relations	W159N9939 Butternut Rd;GV	County Line School	NRPT	730	TEO138
25-018753	11/20/25 07:52	Public Relations	N128W21760 Holy Hill Rd;A;GV	Holy Hill Shell	NRPT	737	DJP083
25-018752	11/20/25 07:26	Public Relations	W204N11968 Goldendale Rd;GV	St. Boniface School	NRPT	737	DJP083
25-018751	11/20/25 06:57	Public Relations	N118W15860 Williams Dr;GV	Kennedy Middle School	NRPT	736	JLS084
25-018750	11/20/25 06:54	Public Relations	W180N11501 River La;GV	Germentown High School	NRPT	737	DJP083
25-018741	11/20/25 01:52	Public Relations	W178N9817 Riversbend Cir E;GV		NRPT	746	TJN9088
25-018737	11/20/25 01:12	Public Relations	N112W18741 Mequon Rd;GV	Kwik Trip GV	NRPT	743	JAR0107
25-018730	11/19/25 18:52	Public Relations	W190N9855 Appleton Av,STORE;GV	Walmart VGTN	NRPT	749	JMH9110
25-018722	11/19/25 14:31	Public Relations	W164N11233 Squire Dr;GV	Speedway GV	NRPT	747	BPD9058
25-018709	11/19/25 09:07	Public Relations	W164N11233 Squire Dr;GV	Speedway GV	NRPT	737	DJP083
25-018699	11/19/25 07:18	Public Relations	N108W14290 Bel Aire La;GV	Bethlehem Lutheran Church	NRPT	737	DJP083
25-018697	11/19/25 06:44	Public Relations	W180N11501 River La;GV	Germentown High School	NRPT	736	JLS084
25-018693	11/19/25 02:05	Public Relations	N112W18741 Mequon Rd;GV	Kwik Trip GV	NRPT	744	ALC9032
25-018691	11/19/25 01:33	Public Relations	W160N10652 Fieldstone Pass;GV		NRPT	746	TJN9088
25-018684	11/18/25 22:59	Public Relations	N112W18741 Mequon Rd;GV	Kwik Trip GV	NRPT	743	JAR0107
25-018667	11/18/25 16:30	Public Relations	N112W18741 Mequon Rd;GV	Kwik Trip GV	NRPT	735	JRS097
25-018664	11/18/25 15:43	Public Relations	N112W18741 Mequon Rd;GV	Kwik Trip GV	NRPT	741	DPK0106
25-018651	11/18/25 09:55	Public Relations	N128W21760 Holy Hill Rd;A;GV	Holy Hill Shell	NRPT	737	DJP083
25-018650	11/18/25 09:40	Public Relations	W154N11492 Fond Du Lac Av;GV	Macarthur Elementary School	NRPT	730	TEO138



Call Simple Lists

Printed On: 12/30/25 07:35

Call#	Reported Date	CAD CFS	Location	Common Name	Disp	Unit#	Officer(s)
25-018647	11/18/25 08:51	Public Relations	N108W14290 Bel Aire La;GV	Bethlehem Lutheran Church	NRPT	733	MMO119
25-018645	11/18/25 08:27	Public Relations	W154N11492 Fond Du Lac Av;GV	Macarthur Elementary School	NRPT	737	DJP083
25-018643	11/18/25 08:26	Public Relations	W159N9939 Butternut Rd;GV	County Line School	NRPT	733	MMO119
25-018642	11/18/25 07:41	Public Relations	N118W15860 Williams Dr;GV	Kennedy Middle School	NRPT	737	DJP083
25-018639	11/18/25 07:17	Public Relations	W156N9636 Pilgrim Rd;GV	Latitudes Coffee House	NRPT	733	MMO119
25-018610	11/17/25 14:49	Public Relations	N116W16316 Main St;GV	The Vault	NRPT	735	JRS097
25-018592	11/17/25 08:26	Public Relations	W154N11492 Fond Du Lac Av;GV	Macarthur Elementary School	NRPT	733	MMO119
25-018588	11/17/25 07:23	Public Relations	W204N11968 Goldendale Rd;GV	St. Boniface School St Boniface Church	NRPT	737	DJP083
25-018587	11/17/25 07:22	Public Relations	N118W15860 Williams Dr;GV	Kennedy Middle School	NRPT	733	MMO119
25-018586	11/17/25 07:08	Public Relations	W180N11501 River La;GV	Germantown High School	NRPT	737	DJP083
25-018561	11/16/25 17:47	Public Relations	N112W18741 Mequon Rd;GV	Kwik Trip GV	NRPT	750	AML9130
25-018543	11/16/25 11:06	Public Relations	N112W17761 Mequon Rd;GV	Berean Bible Society VGTN	NRPT	733	MMO119
25-018542	11/16/25 11:04	Public Relations	W172N11183 Division Rd;GV	Faith Lutheran Church	NRPT	733	MMO119
25-018532	11/16/25 08:10	Public Relations	W204N11968 Goldendale Rd;GV	St. Boniface School St Boniface Church	NRPT	733	MMO119
25-018527	11/16/25 07:24	Public Relations	W180N11501 River La;GV	Germantown High School	NRPT	721	RPB092
25-018496	11/15/25 13:45	Public Relations	N112W18741 Mequon Rd;GV	Kwik Trip GV	NRPT	745	ALP9041
25-018490	11/15/25 11:50	Public Relations	N112W16877 Mequon Rd;GV	Germantown Police Department	NRPT	720	SDJ101
25-018489	11/15/25 11:14	Public Relations	W156N11261 Pilgrim Rd;GV	Walgreens Vgtn	NRPT	736	JLS084
25-018484	11/15/25 10:00	Public Relations	W162N11870 Park Av;GV	Firemen's Park Firemans Park GV	NRPT	737	DJP083
25-018483	11/15/25 09:39	Public Relations	W162N11870 Park Av;GV	Firemen's Park	NRPT	742	AWD0105
25-018472	11/15/25 04:45	Public Relations	N112W18741 Mequon Rd;GV	Kwik Trip GV	NRPT	738	NWK1173
25-018452	11/14/25 19:06	Public Relations	N112W16200 Mequon Rd;GV	Pick N Save	NRPT	749	JMH9110
25-018449	11/14/25 18:28	Public Relations	W190N9855 Appleton Av,STORE;GV	Walmart VGTN	NRPT	721	RPB092
25-018408	11/14/25 06:39	Public Relations	W180N11501 River La;GV	Germantown High School	NRPT	736	JLS084



Call Simple Lists

Printed On: 12/30/25 07:35

Call#	Reported Date	CAD CFS	Location	Common Name	Disp	Unit#	Officer(s)
25-018404	11/14/25 05:13	Public Relations	N112W18741 Mequon Rd;GV	Kwik Trip GV	NRPT	707	JR098
25-018402	11/14/25 04:31	Public Relations	N112W18741 Mequon Rd;GV	Kwik Trip GV	NRPT	737	DJP083
25-018393	11/14/25 00:13	Public Relations	N112W18741 Mequon Rd;GV	Kwik Trip GV	NRPT	743	JAR0107
25-018378	11/13/25 14:58	Public Relations	N118W15860 Williams Dr;GV	Kennedy Middle School	NRPT	730	TEO138
25-018366	11/13/25 10:48	Public Relations	N112W16877 Mequon Rd;GV	Germanontown Police Department	CAN		
25-018363	11/13/25 09:57	Public Relations	W165N10749 Wagon Tr;GV	Alt Bauer Park	NRPT	736	JLS084
25-018356	11/13/25 08:07	Public Relations	W159N9939 Butternut Rd;GV	County Line School	NRPT	736	JLS084
25-018354	11/13/25 07:35	Public Relations	N1108W14290 Bel Aire La;GV	Bethlehem Lutheran Church	NRPT	736	JLS084
25-018353	11/13/25 07:21	Public Relations	W204N11968 Goldendale Rd;GV	St. Boniface School St Boniface Church	NRPT	737	DJP083
25-018349	11/13/25 06:44	Public Relations	W180N11501 River La;GV	Germanontown High School	NRPT	737	DJP083
25-018343	11/13/25 04:35	Public Relations	W166N10555 Surrey Dr;GV		NRPT	746	TJN9088
25-018340	11/13/25 02:24	Public Relations	N112W18741 Mequon Rd;GV	Kwik Trip GV	NRPT	737	DJP083
25-018338	11/13/25 01:43	Public Relations	N96W14693 Emerald La;GV	Creative Supply Chain Solutions LLC	NRPT	746	TJN9088
25-018337	11/13/25 01:22	Public Relations	W166N10193 Calico La;GV		NRPT	746	TJN9088
25-018302	11/12/25 13:22	Public Relations	2900 Hy 167;RV	Kwik Trip RV	NRPT	737	DJP083
25-018293	11/12/25 11:18	Public Relations	W178N9653 Riversbend La;GV	Speedway GV	NRPT	732	ARB093
25-018292	11/12/25 11:08	Public Relations	N96W17970 County Line Rd;GV	AT&T	NRPT	732	ARB093
25-018291	11/12/25 11:02	Public Relations	W190N9855 Appleton Av;B;GV	Subway Vgtn Walmart	NRPT	732	ARB093
25-018289	11/12/25 10:35	Public Relations	W154N11492 Fond Du Lac Av;GV	Macarthur Elementary School	NRPT	730	TEO138
25-018286	11/12/25 08:47	Public Relations	W164N11271 Squire Dr;GV	Edward Jones	NRPT	732	ARB093
25-018282	11/12/25 07:25	Public Relations	N108W14290 Bel Aire La;GV	Bethlehem Lutheran Church	NRPT	737	DJP083
25-018281	11/12/25 07:22	Public Relations	W204N11968 Goldendale Rd;GV	St. Boniface School St Boniface Church	NRPT	733	MMO119
25-018280	11/12/25 07:02	Public Relations	N118W15860 Williams Dr;GV	Kennedy Middle School	NRPT	750	AML9130
25-018279	11/12/25 06:54	Public Relations	W180N11501 River La;GV	Germanontown High School	NRPT	733	MMO119



Call Simple Lists

Printed On: 12/30/25 07:35

Call#	Reported Date	CAD CFS	Location	Common Name	Disp	Unit#	Officer(s)
25-018243	11/11/25 17:23	Public Relations	N112W18741 Mequon Rd;GV	Kwik Trip GV	NRPT	747	BPD9058
25-018220	11/11/25 09:35	Public Relations	W154N11492 Fond Du Lac Av;GV	Macarthur Elementary School	NRPT	730	TEO138
25-018219	11/11/25 09:16	Public Relations	W164N11233 Squire Dr;GV	Speedway GV	NRPT	737	DJP083
25-018212	11/11/25 04:36	Public Relations	N112W18741 Mequon Rd;GV	Kwik Trip GV	NRPT	743	JAR0107
25-018180	11/10/25 15:08	Public Relations	N112W15800 Mequon Rd;6;GV	Subway Vgtn	NRPT	735	JRS097
25-018171	11/10/25 12:35	Public Relations	N112W16040 Mequon Rd;GV	Roberts Frozen Custard	NRPT	733	MMO119
25-018165	11/10/25 09:32	Public Relations	W204N11968 Goldendale Rd;GV	St. Boniface School St Boniface Church	NRPT	733	MMO119
25-018162	11/10/25 09:27	Public Relations	W180N11501 River La;GV	Germantown High School	NRPT	733	MMO119
25-018154	11/10/25 08:03	Public Relations	W159N9939 Butternut Rd;GV	County Line School	NRPT	750	AML9130
25-018152	11/10/25 07:37	Public Relations	N108W14290 Bel Aire La;GV	Bethlehem Lutheran Church	NRPT	750	AML9130
25-018150	11/10/25 06:46	Public Relations	W180N11501 River La;GV	Germantown High School	NRPT	736	JLS084
25-018149	11/10/25 06:27	Public Relations	W204N11968 Goldendale Rd;GV	St. Boniface School St Boniface Church	NRPT	736	JLS084
25-018144	11/10/25 02:35	Public Relations	N112W18741 Mequon Rd;GV	Kwik Trip GV	NRPT	744	ALC9032
25-018131	11/09/25 20:29	Public Relations	N116W16218 Main St;GV	Bubs Irish Pub	NRPT	741	DPK0106
25-018120	11/09/25 12:19	Public Relations	N96W17698 County Line Rd;GV	Panda Express GV	NRPT	733	MMO119
25-018117	11/09/25 11:05	Public Relations	W164N11325 Squire Dr;GV	Life Church	NRPT	736	JLS084
25-018116	11/09/25 10:37	Public Relations	N108W14290 Bel Aire La;GV	Bethlehem Lutheran Church	NRPT	733	MMO119
25-018112	11/09/25 09:35	Public Relations	W180N11501 River La;GV	Germantown High School	NRPT	730	TEO138
25-018111	11/09/25 09:21	Public Relations	N104W14181 Donges Bay Rd;GV	St John United Church Of Christ	NRPT	733	MMO119
25-018110	11/09/25 09:18	Public Relations	W156N10660 Pilgrim Rd;GV	Lutheran Church Of Living Christ	NRPT	733	MMO119
25-018109	11/09/25 09:08	Public Relations	W156N10041 Pilgrim Rd;GV	Cross Way Church	NRPT	733	MMO119
25-018105	11/09/25 07:23	Public Relations	N112W16510 Mequon Rd;A;GV	Starbucks VGTN - Mequon Rd.	NRPT	733	MMO119
25-018103	11/09/25 07:12	Public Relations	N112W16510 Mequon Rd;A;GV	Starbucks VGTN - Mequon Rd.	NRPT	736	JLS084
25-018098	11/09/25 02:24	Public Relations	N112W18741 Mequon Rd;GV	Kwik Trip GV	NRPT	744	ALC9032



Call Simple Lists

Printed On: 12/30/25 07:35

Call#	Reported Date	CAD CFS	Location	Common Name	Disp	Unit#	Officer(s)
25-018078	11/08/25 19:54	Public Relations	N112W16510 Mequon Rd;2;GV	Jersey Mike's Subs	NRPT	749	JMH9110
25-018074	11/08/25 18:57	Public Relations	N112W16200 Mequon Rd;GV	Pick N Save	NRPT	749	JMH9110
25-018060	11/08/25 14:04	Public Relations	N112W16200 Mequon Rd;GV	Pick N Save	NRPT	737	DJP083
25-018057	11/08/25 11:46	Public Relations	N96W18200 County Line Rd;GV	Fleet Farm GV	NRPT	737	DJP083
25-018040	11/08/25 03:09	Public Relations	N112W18741 Mequon Rd;GV	Kwik Trip GV	NRPT	743	JAR0107
25-017993	11/07/25 11:58	Public Relations	W159N9939 Butternut Rd;GV	County Line School	NRPT	730	TEO138
25-017991	11/07/25 11:49	Public Relations	W130N10200 Town 9 Pkwy;GV	DPW GV Germantown DPW	NRPT	736	JLS084
25-017989	11/07/25 10:56	Public Relations	W173N10915 Bernies Way,BLDG;GV	Virginia Highlands,BLDG	NRPT	732	ARB093
25-017985	11/07/25 08:44	Public Relations	W159N9939 Butternut Rd;GV	County Line School	NRPT	731	KCL088
25-017982	11/07/25 08:06	Public Relations	W159N9939 Butternut Rd;GV	County Line School	NRPT	736	JLS084
25-017981	11/07/25 07:42	Public Relations	N108W14290 Bel Aire La;GV	Bethlehem Lutheran Church	NRPT	736	JLS084
25-017978	11/07/25 07:22	Public Relations	W204N11968 Goldendale Rd;GV	St. Boniface School St Boniface Church	NRPT	737	DJP083
25-017975	11/07/25 07:01	Public Relations	W180N11501 River La;GV	Germantown High School	NRPT	737	DJP083
25-017965	11/07/25 01:55	Public Relations	W164N11233 Squire Dr;GV	Speedway GV	NRPT	746	TJN9088
25-017938	11/06/25 10:47	Public Relations	W154N11492 Fond Du Lac Av;GV	Macarthur Elementary School	NRPT	730	TEO138
25-017932	11/06/25 07:42	Public Relations	N108W14290 Bel Aire La;GV	Bethlehem Lutheran Church	NRPT	737	DJP083
25-017929	11/06/25 07:19	Public Relations	N118W15860 Williams Dr;GV	Kennedy Middle School	NRPT	750	AML9130
25-017922	11/06/25 03:34	Public Relations	N112W18741 Mequon Rd;GV	Kwik Trip GV	NRPT	737	DJP083
25-017905	11/05/25 19:59	Public Relations	N112W18741 Mequon Rd;GV	Kwik Trip GV	NRPT	747	BPD9058
25-017889	11/05/25 15:32	Public Relations	W156N9650 Pilgrim Rd;GV	Citgo	NRPT	745	ALP9041
25-017874	11/05/25 11:05	Public Relations	N96W17698 County Line Rd;GV	Panda Express GV	NRPT	733	MMO119
25-017856	11/05/25 07:08	Public Relations	N108W14290 Bel Aire La;GV	Bethlehem Lutheran Church	NRPT	733	MMO119
25-017855	11/05/25 07:04	Public Relations	W180N11501 River La;GV	Germantown High School	NRPT	750	AML9130
25-017854	11/05/25 06:55	Public Relations	N118W15860 Williams Dr;GV	Kennedy Middle School	NRPT	737	DJP083
25-017819	11/04/25 15:21	Public Relations	N112W18741 Mequon Rd;GV	Kwik Trip GV	NRPT	735	JRS097
25-017799	11/04/25 09:37	Public Relations	W154N11492 Fond Du Lac Av;GV	Macarthur Elementary School	NRPT	730	TEO138



Call Simple Lists

Printed On: 12/30/25 07:35

Call#	Reported Date	CAD CFS	Location	Common Name	Disp	Unit#	Officer(s)
25-017796	11/04/25 07:57	Public Relations	W159N9939 Butternut Rd;GV	County Line School	NRPT	736	JLS084
25-017795	11/04/25 07:40	Public Relations	N112W18741 Mequon Rd;GV	Kwik Trip GV	NRPT	736	JLS084
25-017793	11/04/25 07:03	Public Relations	W180N11501 River La;GV	Germantown High School	NRPT	750	AML9130
25-017792	11/04/25 06:46	Public Relations	N118W15860 Williams Dr;GV	Kennedy Middle School	NRPT	736	JLS084
25-017787	11/04/25 02:19	Public Relations	N112W18741 Mequon Rd;GV	Kwik Trip GV	NRPT	744	ALC9032
25-017775	11/03/25 21:32	Public Relations	N96W18640 County Line Rd;GV	Chilis Grill & Bar	NRPT	741	DPK0106
25-017771	11/03/25 18:45	Public Relations	W190N9855 Appleton Av;STORE;GV	Walmart VGTN	NRPT	751	ALP9041 KMK9135
25-017770	11/03/25 18:27	Public Relations	N96W18794 County Line Rd;GV	Petco Vgtn	NRPT	735	JRS097
25-017769	11/03/25 17:48	Public Relations	W190N9855 Appleton Av;STORE;GV	Walmart VGTN	NRPT	711	CAF118
25-017767	11/03/25 15:46	Public Relations	N112W16760 Mequon Rd;D;GV	Dental Professionals	NRPT	735	JRS097
25-017759	11/03/25 13:29	Public Relations	W190N9855 Appleton Av;STORE;GV	Walmart VGTN	NRPT	736	JLS084
25-017737	11/03/25 08:38	Public Relations	W154N11492 Fond Du Lac Av;GV	Macarthur Elementary School	NRPT	736	JLS084
25-017734	11/03/25 07:25	Public Relations	W204N11968 Goldendale Rd;GV	St. Boniface School St Boniface Church	NRPT	733	MMO119
25-017730	11/03/25 06:44	Public Relations	N118W15860 Williams Dr;GV	Kennedy Middle School	NRPT	736	JLS084
25-017728	11/03/25 06:37	Public Relations	W180N11501 River La;GV	Germantown High School	NRPT	733	MMO119
25-017714	11/02/25 19:39	Public Relations	N112W18741 Mequon Rd;GV	Kwik Trip GV	NRPT	747	BPD9058
25-017702	11/02/25 13:59	Public Relations	N112W16200 Mequon Rd;GV	Pick N Save	NRPT	737	DJP083
25-017698	11/02/25 11:22	Public Relations	N112W18741 Mequon Rd;GV	Kwik Trip GV	NRPT	742	AWD0105
25-017691	11/02/25 09:53	Public Relations	W156N9636 Pilgrim Rd;GV	Latitudes Coffee House	NRPT	737	DJP083
25-017684	11/02/25 07:28	Public Relations	W180N11501 River La;GV	Germantown High School	NRPT	730	TEO138
25-017678	11/02/25 02:42	Public Relations	N112W18741 Mequon Rd;GV	Kwik Trip GV	NRPT	744	ALC9032
25-017676	11/02/25 01:13	Public Relations	N112W18741 Mequon Rd;GV	Kwik Trip GV	NRPT	743	JAR0107
25-017652	11/01/25 14:48	Public Relations	W186N9754 Appleton Av;GV	Menards Vgtn	NRPT	721	RPB092
25-017651	11/01/25 13:57	Public Relations	W190N9855 Appleton Av;STORE;GV	Walmart VGTN	NRPT	721	RPB092



Call Simple Lists

Printed On: 12/30/25 07:35

Call#	Reported Date	CAD CFS	Location	Common Name	Disp	Unit#	Officer(s)
25-017638	11/01/25 10:46	Public Relations	W190N9855 Appleton Av,STORE;GV	Walmart VGTN	NRPT	742	AWD0105
25-017633	11/01/25 09:58	Public Relations	W190N9855 Appleton Av,STORE;GV	Walmart VGTN	NRPT	742	AWD0105
25-017617	11/01/25 01:18	Public Relations	N112W18741 Mequon Rd;GV	Kwik Trip GV	NRPT	746	TJN9088
24-021474	11/29/24 15:32	Public Relations	W188N10963 Maple Rd;GV	Kwik Trip GV - VACANT BLDG Kwik Trip VGTN	NRPT	747	SAH0104
24-021469	11/29/24 13:02	Public Relations	W188N10963 Maple Rd;GV	Kwik Trip GV - VACANT BLDG Kwik Trip VGTN	NRPT	750	JAR0107
24-021461	11/29/24 10:30	Public Relations	W156N9636 Pilgrim Rd;GV	Latitudes Coffee House	NRPT	743	JSC079
24-021451	11/29/24 05:10	Public Relations	N96W18200 County Line Rd;GV	Fleet Farm GV Fleet Farm Vgtn	NRPT	744	NWK1173
24-021446	11/29/24 01:31	Public Relations	W178N9653 Riversbend La;GV	Speedway GV Speedway Vgtn Riversbend Ln	NRPT	754	EWB9042
24-021422	11/28/24 09:24	Public Relations	W188N10963 Maple Rd;GV	Kwik Trip GV - VACANT BLDG Kwik Trip VGTN	NRPT	745	NRF1174
24-021407	11/28/24 00:47	Public Relations	W178N9653 Riversbend La;GV	Speedway GV Speedway Vgtn Riversbend Ln	NRPT	748	DPK0106
24-021376	11/27/24 12:20	Public Relations	N116W16316 Main St;GV	The Vault	NRPT	713	JLP137
24-021358	11/27/24 07:13	Public Relations	W156N10041 Pilgrim Rd;GV	Cross Way Church	NRPT	733	ARB093
24-021356	11/27/24 01:35	Public Relations	W188N10963 Maple Rd;GV	Kwik Trip GV - VACANT BLDG Kwik Trip VGTN	NRPT	738	GWD122
24-021332	11/26/24 11:23	Public Relations	W156N11261 Pilgrim Rd;GV	Walgreens Vgtn	NRPT	745	NRF1174
24-021326	11/26/24 10:10	Public Relations	W188N10963 Maple Rd;GV	Kwik Trip GV - VACANT BLDG Kwik Trip VGTN	NRPT	745	NRF1174
24-021321	11/26/24 08:03	Public Relations	N112W15800 Mequon Rd,STORE;GV	Sendiks Vgtn	NRPT	753	ALP9041
24-021306	11/26/24 01:55	Public Relations	W188N10963 Maple Rd;GV	Kwik Trip GV - VACANT BLDG Kwik Trip VGTN	NRPT	738	GWD122
24-021293	11/25/24 19:40	Public Relations	W182N9606 Appleton Av,104;GV	Crumbi Metro Cigars	NRPT	743	JSC079
24-021273	11/25/24 11:25	Public Relations	W178N9912 Rivercrest Dr,101;GV	Jbj Properties	NRPT	706	PAS117
24-021264	11/25/24 09:43	Public Relations	W154N11492 Fond Du Lac Av;GV	Macarthur Elementary School	NRPT	731	TEO138



Call Simple Lists

Printed On: 12/30/25 07:35

Call#	Reported Date	CAD CFS	Location	Common Name	Disp	Unit#	Officer(s)
24-021258	11/25/24 07:23	Public Relations	N115W19150 Edison Dr;GV	The Elite Soccer Academy Happy Hounds Llc	NRPT	731	TEO138
24-021256	11/25/24 07:10	Public Relations	N128W21760 Holy Hill Rd,A;GV	Holy Hill Shell	NRPT	750	JAR0107
24-021254	11/25/24 06:56	Public Relations	N112W16510 Mequon Rd,A;GV	Starbucks VGTN - Mequon Rd.	NRPT	740	JLS084
24-021252	11/25/24 02:17	Public Relations	W188N10963 Maple Rd;GV	Kwik Trip GV - VACANT BLDG Kwik Trip VGTN	NRPT	738	GWD122
24-021239	11/24/24 19:05	Public Relations	N128W21760 Holy Hill Rd,A;GV	Holy Hill Shell	NRPT	753	ALP9041
24-021211	11/24/24 07:24	Public Relations	W180N11501 River La;GV	Germantown High School	NRPT	722	RPB092
24-021207	11/24/24 06:44	Public Relations	W188N10963 Maple Rd;GV	Kwik Trip GV - VACANT BLDG Kwik Trip VGTN	NRPT	750	JAR0107
24-021190	11/23/24 23:11	Public Relations	W188N10963 Maple Rd;GV	Kwik Trip GV - VACANT BLDG Kwik Trip VGTN	NRPT	747	SAH0104
24-021159	11/23/24 09:26	Public Relations	W186N9754 Appleton Av;GV	Menards Vgtn	NRPT	753	ALP9041
24-021158	11/23/24 09:25	Public Relations	W188N10963 Maple Rd;GV	Kwik Trip GV - VACANT BLDG Kwik Trip VGTN	NRPT	745	NRF1174
24-021157	11/23/24 09:24	Public Relations	W156N9650 Pilgrim Rd;GV	Citgo Clark Oil	NRPT	750	JAR0107
24-021143	11/23/24 02:15	Public Relations	W188N10963 Maple Rd;GV	Kwik Trip GV - VACANT BLDG Kwik Trip VGTN	NRPT	715	JR098
24-021127	11/22/24 20:49	Public Relations	W188N10963 Maple Rd;GV	Kwik Trip GV - VACANT BLDG Kwik Trip VGTN	NRPT	747	SAH0104
24-021120	11/22/24 17:22	Public Relations	W156N9650 Pilgrim Rd;GV	Citgo Clark Oil	NRPT	717	BEM126
24-021102	11/22/24 11:46	Public Relations	W188N10963 Maple Rd;GV	Kwik Trip GV - VACANT BLDG Kwik Trip VGTN	NRPT	745	NRF1174
24-021093	11/22/24 09:10	Public Relations	W154N11492 Fond Du Lac Av;GV	Macarthur Elementary School	NRPT	731	TEO138
24-021069	11/22/24 00:37	Public Relations	2900 Hy 167;RV	Kwik Trip VRICH	NRPT	736	MMO119
24-021061	11/21/24 19:13	Public Relations	N112W15800 Mequon Rd,6;GV	Subway Vgtn	NRPT	749	AWD0105
24-021055	11/21/24 16:48	Public Relations	W188N10963 Maple Rd;GV	Kwik Trip GV - VACANT BLDG Kwik Trip VGTN	NRPT	741	DJP083
24-021001	11/20/24 23:56	Public Relations	W159N9879 Butternut Rd;GV		NRPT	748	DPK0106
24-020986	11/20/24 15:24	Public Relations	W188N10963 Maple Rd;GV	Kwik Trip GV - VACANT BLDG Kwik Trip VGTN	NRPT	747	SAH0104



Call Simple Lists

Printed On: 12/30/25 07:35

Call#	Reported Date	CAD CFS	Location	Common Name	Disp	Unit#	Officer(s)
24-020957	11/20/24 03:26	Public Relations	W188N10963 Maple Rd;GV	Kwik Trip GV - VACANT BLDG Kwik Trip VGTN	NRPT	748	DPK0106
24-020954	11/20/24 01:47	Public Relations	W188N10963 Maple Rd;GV	Kwik Trip GV - VACANT BLDG Kwik Trip VGTN	NRPT	738	GWD122
24-020948	11/19/24 21:57	Public Relations	W188N10963 Maple Rd;GV	Kwik Trip GV - VACANT BLDG Kwik Trip VGTN	NRPT	741	DJP083
24-020903	11/19/24 07:21	Public Relations	W188N10963 Maple Rd;GV	Kwik Trip GV - VACANT BLDG Kwik Trip VGTN	NRPT	750	JAR0107
24-020874	11/18/24 14:13	Public Relations	N116W16316 Main St;GV	The Vault	NRPT	731	TEO138
24-020873	11/18/24 14:02	Public Relations	N115W19150 Edison Dr;GV	The Elite Soccer Academy Happy Hounds Lic	NRPT	731	TEO138
24-020860	11/18/24 10:59	Public Relations	W188N10963 Maple Rd;GV	Kwik Trip GV - VACANT BLDG Kwik Trip VGTN	NRPT	750	JAR0107
24-020856	11/18/24 09:38	Public Relations	W154N11492 Fond Du Lac Av;GV	Macarthur Elementary School	NRPT	731	TEO138
24-020845	11/18/24 07:23	Public Relations	W156N9650 Pilgrim Rd;GV	Citgo Clark Oil	NRPT	750	JAR0107
24-020831	11/18/24 02:07	Public Relations	W188N10963 Maple Rd;GV	Kwik Trip GV - VACANT BLDG Kwik Trip VGTN	NRPT	738	GWD122
24-020775	11/17/24 08:33	Public Relations	W188N10963 Maple Rd;GV	Kwik Trip GV - VACANT BLDG Kwik Trip VGTN	NRPT	745	NRF1174
24-020774	11/17/24 08:32	Public Relations	N128W21760 Holy Hill Rd,A;GV	Holy Hill Shell	NRPT	750	JAR0107
24-020767	11/17/24 07:14	Public Relations	W180N11501 River La;GV	Germentown High School	NRPT	722	RPB092
24-020758	11/17/24 04:14	Public Relations	N119W15016 Ivy Ln;GV		NRPT	754	EWB9042
24-020757	11/17/24 04:09	Public Relations	W150N11759 Mistletoe Ct;GV		NRPT	754	EWB9042
24-020752	11/17/24 01:48	Public Relations	N106W16181 Old Farm Rd;GV		NRPT	736	MMO119
24-020750	11/17/24 01:15	Public Relations	W188N10963 Maple Rd;GV	Kwik Trip GV - VACANT BLDG Kwik Trip VGTN	NRPT	715	JR098
24-020744	11/16/24 23:43	Public Relations	W178N9653 Riversbend La;GV	Speedway GV Speedway Vgtn Riversbend Ln	NRPT	748	DPK0106
24-020711	11/16/24 09:46	Public Relations	Pilgrim Rd/Daniels Dr;GV		NRPT	741	DJP083
24-020710	11/16/24 09:43	Public Relations	W188N10963 Maple Rd;GV	Kwik Trip GV - VACANT BLDG Kwik Trip VGTN	NRPT	745	NRF1174
24-020708	11/16/24 09:32	Public Relations	Mequon Rd/Pilgrim Rd;GV		NRPT	722	RPB092



Call Simple Lists

Printed On: 12/30/25 07:35

Call#	Reported Date	CAD CFS	Location	Common Name	Disp	Unit#	Officer(s)
24-020702	11/16/24 07:13	Public Relations	W188N10963 Maple Rd;GV	Kwik Trip GV - VACANT BLDG Kwik Trip VGTN	NRPT	750	JAR0107
24-020693	11/16/24 02:59	Public Relations	N112W16877 Mequon Rd;GV	Germandown Police Department	NRPT	715	JR098
24-020692	11/16/24 02:57	Public Relations	W156N11513 Pilgrim Rd;105;GV		NRPT	736	MMO119
24-020691	11/16/24 02:51	Public Relations	W152N11520 Valley Dr;GV		NRPT	736	MMO119
24-020688	11/16/24 02:16	Public Relations	W188N10963 Maple Rd;GV	Kwik Trip GV - VACANT BLDG Kwik Trip VGTN	NRPT	748	DPK0106
24-020687	11/16/24 02:04	Public Relations	2900 Hy 167;RV	Kwik Trip VRICH	NRPT	736	MMO119
24-020677	11/15/24 22:42	Public Relations	N98W15684 School Rd;GV		NRPT	748	DPK0106
24-020613	11/14/24 10:09	Public Relations	W154N11492 Fond Du Lac Av;GV	Macarthur Elementary School	NRPT	731	TEO138
24-020604	11/14/24 07:34	Public Relations	W156N9636 Pilgrim Rd;GV	Latitudes Coffee House	NRPT	753	ALP9041
24-020596	11/14/24 01:14	Public Relations	W188N10963 Maple Rd;GV	Kwik Trip GV - VACANT BLDG Kwik Trip VGTN	NRPT	738	GWD122
24-020585	11/13/24 16:19	Public Relations	N128W21760 Holy Hill Rd;A;GV	Holy Hill Shell	NRPT	741	DJP083
24-020552	11/13/24 02:47	Public Relations	W188N10963 Maple Rd;GV	Kwik Trip GV - VACANT BLDG Kwik Trip VGTN	NRPT	738	GWD122
24-020535	11/12/24 16:19	Public Relations	W188N10963 Maple Rd;GV	Kwik Trip GV - VACANT BLDG Kwik Trip VGTN	NRPT	741	DJP083
24-020530	11/12/24 15:09	Public Relations	N128W21760 Holy Hill Rd;A;GV	Holy Hill Shell	NRPT	749	AWD0105
24-020511	11/12/24 09:21	Public Relations	W156N10041 Pilgrim Rd;GV	Cross Way Church	NRPT	707	DTV099
24-020495	11/12/24 01:21	Public Relations	N98W16471 Concord Rd;GV		NRPT	754	EWB9042
24-020491	11/12/24 00:31	Public Relations	W188N10963 Maple Rd;GV	Kwik Trip GV - VACANT BLDG Kwik Trip VGTN	NRPT	738	GWD122
24-020489	11/12/24 00:26	Public Relations	W141N9739 Knollcrest Cir;GV		NRPT	754	EWB9042
24-020469	11/11/24 14:54	Public Relations	W188N10963 Maple Rd;GV	Kwik Trip GV - VACANT BLDG Kwik Trip VGTN	NRPT	747	SAH0104
24-020467	11/11/24 14:42	Public Relations	W154N11492 Fond Du Lac Av;GV	Macarthur Elementary School	NRPT	743	JSC079
24-020446	11/11/24 09:16	Public Relations	N128W21760 Holy Hill Rd;A;GV	Holy Hill Shell	NRPT	750	JAR0107
24-020435	11/11/24 06:47	Public Relations	W156N9636 Pilgrim Rd;GV	Latitudes Coffee House	NRPT	753	ALP9041



Call Simple Lists

Printed On: 12/30/25 07:35

Call#	Reported Date	CAD CFS	Location	Common Name	Disp	Unit#	Officer(s)
24-020427	11/11/24 01:49	Public Relations	W151N11696 Valley Ct;GV		NRPT	754	EWB9042
24-020426	11/11/24 01:33	Public Relations	N114W14535 Wrenwood Ct;GV		NRPT	754	EWB9042
24-020423	11/11/24 00:42	Public Relations	2900 Hy 167;RV	Kwik Trip VRICH	NRPT	736	MMO119
24-020422	11/11/24 00:40	Public Relations	W188N10963 Maple Rd;GV	Kwik Trip GV - VACANT BLDG Kwik Trip	CAN	736	MMO119
24-020408	11/10/24 18:41	Public Relations	N96W17698 County Line Rd;GV	Panda Express GV	NRPT	717	BEM126
24-020407	11/10/24 17:42	Public Relations	N112W15800 Mequon Rd;GV	Subway Vgtn	NRPT	747	SAH0104
24-020401	11/10/24 16:24	Public Relations	N96W19180 County Line Rd;GV	Dollar Tree	NRPT	737	JRS097
24-020384	11/10/24 09:27	Public Relations	W188N10963 Maple Rd;GV	Kwik Trip GV - VACANT BLDG Kwik Trip VGTN	NRPT	745	NRF1174
24-020380	11/10/24 09:08	Public Relations	N115W19150 Edison Dr;GV	The Elite Soccer Academy Happy Hounds Llc	NRPT	731	TEO138
24-020377	11/10/24 08:40	Public Relations	W188N10963 Maple Rd;GV	Kwik Trip GV - VACANT BLDG Kwik Trip VGTN	NRPT	753	ALP9041
24-020367	11/10/24 07:17	Public Relations	W188N10963 Maple Rd;GV	Kwik Trip GV - VACANT BLDG Kwik Trip VGTN	NRPT	750	JAR0107
24-020349	11/10/24 01:16	Public Relations	W188N10963 Maple Rd;GV	Kwik Trip GV - VACANT BLDG Kwik Trip VGTN	NRPT	715	JR098
24-020339	11/09/24 23:07	Public Relations	W188N10963 Maple Rd;GV	Kwik Trip GV - VACANT BLDG Kwik Trip VGTN	NRPT	747	SAH0104
24-020322	11/09/24 16:18	Public Relations	W190N9855 Appleton AV,STORE;GV	Walmart VGTN	NRPT	737	JRS097
24-020321	11/09/24 16:15	Public Relations	W188N10963 Maple Rd;GV	Kwik Trip GV - VACANT BLDG Kwik Trip VGTN	NRPT	741	DJP083
24-020297	11/09/24 08:24	Public Relations	W188N10963 Maple Rd;GV	Kwik Trip GV - VACANT BLDG Kwik Trip VGTN	NRPT	753	ALP9041
24-020287	11/09/24 04:27	Public Relations	W188N10963 Maple Rd;GV	Kwik Trip GV - VACANT BLDG Kwik Trip	NRPT	748	DPK0106
24-020286	11/09/24 04:00	Public Relations	W188N10963 Maple Rd;GV	Kwik Trip GV - VACANT BLDG Kwik Trip VGTN	NRPT	715	JR098
24-020282	11/09/24 01:58	Public Relations	W188N10963 Maple Rd;GV	Kwik Trip GV - VACANT BLDG Kwik Trip VGTN	NRPT	752	ALC9032



Call Simple Lists

Printed On: 12/30/25 07:35

Call#	Reported Date	CAD CFS	Location	Common Name	Disp	Unit#	Officer(s)
24-020269	11/08/24 21:36	Public Relations	W188N10963 Maple Rd;GV	Kwik Trip GV - VACANT BLDG Kwik Trip VGTN	NRPT	747	SAH0104
24-020260	11/08/24 17:26	Public Relations	W188N10963 Maple Rd;GV	Kwik Trip GV - VACANT BLDG Kwik Trip	NRPT	749	AWD0105 CIV1
24-020251	11/08/24 14:18	Public Relations	W164N11233 Squire Dr;GV	Speedway GV Speedway Vgtn Squire Dr	NRPT	737	JRS097
24-020239	11/08/24 12:21	Public Relations	W164N10960 Squire Dr;GV		NRPT	753	ALP9041
24-020238	11/08/24 12:17	Public Relations	N108W16575 Carriage Av;GV		NRPT	753	ALP9041
24-020226	11/08/24 08:34	Public Relations	W188N10963 Maple Rd;GV	Kwik Trip GV - VACANT BLDG Kwik Trip VGTN	NRPT	740	JLS084
24-020208	11/08/24 02:29	Public Relations	W188N10963 Maple Rd;GV	Kwik Trip GV - VACANT BLDG Kwik Trip VGTN	NRPT	738	GWD122
24-020191	11/07/24 20:06	Public Relations	N112W16040 Mequon Rd;GV	Roberts Frozen Custard	NRPT	749	AWD0105
24-020186	11/07/24 17:16	Public Relations	N112W16510 Mequon Rd,2;GV	Jersey Mike's Subs	NRPT	741	DJP083
24-020181	11/07/24 15:31	Public Relations	W178N9912 Rivercrest Dr,101;GV	Jbj Properties	NRPT	733	ARB093
24-020153	11/07/24 10:15	Public Relations	W154N11492 Fond Du Lac Av;GV	Macarthur Elementary School	NRPT	731	TEO138
24-020134	11/07/24 02:59	Public Relations	W188N10963 Maple Rd;GV	Kwik Trip GV - VACANT BLDG Kwik Trip VGTN	NRPT	738	GWD122
24-020130	11/07/24 00:33	Public Relations	W156N11513 Pilgrim Rd,105;GV		NRPT	754	EWB9042
24-020129	11/07/24 00:08	Public Relations	2900 Hy 167;RV	Kwik Trip VRICH	NRPT	736	MMO119
24-020121	11/06/24 19:26	Public Relations	N112W16040 Mequon Rd;GV	Roberts Frozen Custard	NRPT	742	JMP080
24-020112	11/06/24 16:57	Public Relations	N128W21760 Holy Hill Rd,A;GV	Holy Hill Shell	NRPT	741	DJP083
24-020081	11/06/24 08:17	Public Relations	W159N9939 Butternut Rd;GV	County Line School	NRPT	731	TEO138
24-020065	11/06/24 04:01	Public Relations	W150N11759 Mistletoe Ct;GV		NRPT	752	ALC9032
24-020057	11/06/24 02:00	Public Relations	W188N10963 Maple Rd;GV	Kwik Trip GV - VACANT BLDG Kwik Trip VGTN	NRPT	752	ALC9032
24-020056	11/06/24 01:18	Public Relations	W164N11233 Squire Dr;GV	Speedway GV Speedway Vgtn Squire Dr	NRPT	738	GWD122
24-020055	11/06/24 01:15	Public Relations	W160N10503 Old Farm Rd;GV		NRPT	736	MMO119
24-020054	11/06/24 01:11	Public Relations	W166N10577 Surrey Dr;GV		NRPT	736	MMO119



Call Simple Lists

Printed On: 12/30/25 07:35

Call#	Reported Date	CAD CFS	Location	Common Name	Disp	Unit#	Officer(s)
24-020050	11/05/24 22:39	Public Relations	W178N9653 Riversbend La;GV	Speedway GV Speedway Vgtn Riversbend Ln	NRPT	754	EWB9042
24-020047	11/05/24 20:25	Public Relations	N112W15800 Mequon Rd,6;GV	Subway Vgtn	NRPT	736	MMO119
24-020046	11/05/24 19:44	Public Relations	N120W15932 Freistadt Rd;GV	American Legion Post Vgtn	NRPT	738	GWD122
24-020045	11/05/24 19:42	Public Relations	W164N11297 Squire Dr,A;GV	Life Church	NRPT	754	EWB9042
24-020044	11/05/24 19:42	Public Relations	W156N10041 Pilgrim Rd;GV	Cross Way Church	NRPT	752	ALC9032
24-020043	11/05/24 19:41	Public Relations	W162N11960 Park Av;GV	Germantown Senior center Germantown Senior Center	NRPT	736	MMO119
24-020032	11/05/24 16:21	Public Relations	W188N10963 Maple Rd;GV	Kwik Trip GV - VACANT BLDG Kwik Trip VGTN	NRPT	747	SAH0104
24-020007	11/05/24 11:40	Public Relations	N96W17698 County Line Rd;GV	Panda Express GV	NRPT	753	ALP9041
24-019997	11/05/24 10:26	Public Relations	N128W21760 Holy Hill Rd,A;GV	Holy Hill Shell	NRPT	750	JAR0107
24-019987	11/05/24 08:44	Public Relations	N112W16760 Mequon Rd,BLDG;GV		NRPT	733	ARB093
24-019960	11/05/24 01:54	Public Relations	W156N11513 Pilgrim Rd,105;GV		NRPT	736	MMO119
24-019959	11/05/24 01:49	Public Relations	N114W15101 Vicksburg Av;GV		NRPT	736	MMO119
24-019958	11/05/24 01:48	Public Relations	W151N11558 Potomac Cir;GV		NRPT	736	MMO119
24-019957	11/05/24 01:46	Public Relations	W151N11556 Potomac Cir;GV		NRPT	736	MMO119
24-019956	11/05/24 01:36	Public Relations	W209N11271 Schiller Dr;GV		NRPT	744	NWK1173
24-019954	11/05/24 00:56	Public Relations	W142N10458 Magnolia Dr;GV		NRPT	754	EWB9042
24-019953	11/05/24 00:48	Public Relations	N107W14177 White Pine Ct;GV		NRPT	754	EWB9042
24-019940	11/04/24 19:05	Public Relations	W188N10963 Maple Rd;GV	Kwik Trip GV - VACANT BLDG Kwik Trip VGTN	NRPT	737	JRS097
24-019925	11/04/24 14:34	Public Relations	W180N11501 River La;GV	Germantown High School	NRPT	751	JMP080 ROT1116
24-019899	11/04/24 07:37	Public Relations	N115W19150 Edison Dr;GV	The Elite Soccer Academy Happy Hounds Llc	NRPT	731	TEO138
24-019876	11/04/24 00:04	Public Relations	W164N11233 Squire Dr;GV	Speedway GV Speedway Vgtn Squire Dr	NRPT	736	MMO119
24-019852	11/03/24 14:23	Public Relations	W164N11233 Squire Dr;GV	Speedway GV Speedway Vgtn Squire Dr	NRPT	737	JRS097



Call Simple Lists

Printed On: 12/30/25 07:35

Call#	Reported Date	CAD CFS	Location	Common Name	Disp	Unit#	Officer(s)
24-019845	11/03/24 12:18	Public Relations	W187N12793 Fond Du Lac Av;GV	Stags Tavern	NRPT	753	ALP9041
24-019840	11/03/24 09:21	Public Relations	W188N10963 Maple Rd;GV	Kwik Trip GV - VACANT BLDG Kwik Trip VGTN	NRPT	753	ALP9041
24-019835	11/03/24 08:11	Public Relations	W180N11501 River La;GV	Germantown High School	NRPT	722	RPB092
24-019816	11/03/24 00:30	Public Relations	W188N10963 Maple Rd;GV	Kwik Trip GV - VACANT BLDG Kwik Trip VGTN	NRPT	747	SAH0104
24-019793	11/02/24 14:59	Public Relations	N128W21760 Holy Hill Rd,A;GV	Holy Hill Shell	NRPT	741	DJP083
24-019771	11/02/24 06:25	Public Relations	W180N11501 River La;GV	Germantown High School	NRPT	738	GWD122
24-019768	11/02/24 02:58	Public Relations	W164N11233 Squire Dr;GV	Speedway GV Speedway Vgtn Squire Dr	NRPT	738	GWD122
24-019752	11/01/24 20:20	Public Relations	W188N10963 Maple Rd;GV	Kwik Trip GV - VACANT BLDG Kwik Trip VGTN	NRPT	741	DJP083
24-019749	11/01/24 19:38	Public Relations	W156N9650 Pilgrim Rd;GV	Citgo Clark Oil	NRPT	751	CAF118 ROT1116
24-019739	11/01/24 16:17	Public Relations	N112W16268 Mequon Rd;GV	Jimmy Johns Vgtn	NRPT	717	BEM126
24-019734	11/01/24 14:50	Public Relations	N112W16760 Mequon Rd,D;GV	Dental Professionals	NRPT	737	JRS097
24-019728	11/01/24 13:15	Public Relations	W156N9650 Pilgrim Rd;GV	Citgo Clark Oil	NRPT	750	JAR0107
24-019707	11/01/24 08:25	Public Relations	N128W21760 Holy Hill Rd,A;GV	Holy Hill Shell	NRPT	750	JAR0107
24-019695	11/01/24 05:33	Public Relations	W188N10963 Maple Rd;GV	Kwik Trip GV - VACANT BLDG Kwik Trip	NRPT	713	JLP137
24-019692	11/01/24 03:54	Public Relations	W164N11233 Squire Dr;GV	Speedway GV Speedway Vgtn Squire Dr	NRPT	736	MMO119
24-019688	11/01/24 02:44	Public Relations	N108W16546 Carriage Av;GV		NRPT	736	MMO119
24-019686	11/01/24 02:38	Public Relations	W164N11233 Squire Dr;GV	Speedway GV Speedway Vgtn Squire Dr	NRPT	738	GWD122

Village of Germantown Police



Roll Call

Officer conducted a K9 track for the suspect of a hit and run crash that fled on foot starting from the Pilgrim Road BP. The track was lost in the area of Fond du Lac Ave and Mequon Road.

25-018817	K9 Other	Disposition	No Report Due
11/21/25 13:4804	N116W16316 Main St	Unit	730
		Officer	TE0138

25-018836	K9 Drugs	Disposition	No Report Due
11/21/25 19:2015	County Line Rd/HY 41 SB	Unit	735
		Officer	JRS097

Officer conducted a K9 drug sniff of a vehicle reference GPD traffic stop 25-18835. No alert.

25-019022	K9 Other	Disposition	No Report Due
11/25/25 13:3359	N132W18473 Rockfield Rd	Unit	730
		Officer	TE0138

K9 Archie visit

Reports - Scheduled Time Report

Nov 1, 2025 at 12:00a to Nov 30, 2025 at 11:45p

Displaying: Show time over 40 hours as overtime Schedules: Training, Fourth of July Celebration Positions: Admin Assistant, Clerk, Clerk/Typist, Comm., Crime Prevention, Detective, Drug Unit, Lieutenant Support, Officer, Property Clerk, School Resource Officer, Supervisor, Supervisor Operations, Supervisor Support, Support Specialist, Systems Specialist Time Types: Regular, OT - Training

Member	Shift Start Date	Shift Start Time	Shift Stop Date	Shift Stop Time	Schedule	Position	Time Type	Regular Hours	Overtime Hours
Anjum, Amani	Nov 4, 2025	10:00a	Nov 4, 2025	2:00p	Training	Officer	OT - Training	4	0
Anjum, Amani	Nov 5, 2025	8:00a	Nov 5, 2025	4:30p	Training	Officer	Regular	8.5	0
Anjum, Amani	Nov 6, 2025	8:00a	Nov 6, 2025	4:30p	Training	Officer	Regular	8.5	0
Anjum, Amani	Nov 7, 2025	8:00a	Nov 7, 2025	4:30p	Training	Officer	Regular	8.5	0
Anjum, Amani	Nov 10, 2025	10:30a	Nov 10, 2025	1:30p	Training	Officer	OT - Training	3	0
Anjum, Amani	Nov 14, 2025	8:00a	Nov 14, 2025	4:30p	Training	Officer	Regular	7.5	1
Anjum, Amani	Nov 19, 2025	5:00p	Nov 19, 2025	9:00p	Training	Officer	Regular	0	4
SUBTOTAL:								40.00	5.00
Bartelt, Adam	Nov 11, 2025	10:30a	Nov 11, 2025	1:30p	Training	Officer	Regular	3	0
Bartelt, Adam	Nov 13, 2025	8:00a	Nov 13, 2025	4:30p	Training	Officer	Regular	8.5	0
Bartelt, Adam	Nov 14, 2025	8:00a	Nov 14, 2025	4:30p	Training	Officer	Regular	8.5	0
Bartelt, Adam	Nov 19, 2025	5:00p	Nov 19, 2025	9:00p	Training	Officer	OT - Training	4	0
SUBTOTAL:								24.00	0.00
Bloch, Ryan	Nov 11, 2025	10:30a	Nov 11, 2025	1:30p	Training	Officer	OT - Training	3	0
SUBTOTAL:								3.00	0.00
Canfield, Alexander	Nov 4, 2025	6:00a	Nov 4, 2025	10:00a	Training	Officer	OT - Training	4	0
Canfield, Alexander	Nov 10, 2025	6:30a	Nov 10, 2025	9:30a	Training	Officer	OT - Training	3	0
Canfield, Alexander	Nov 12, 2025	8:00a	Nov 12, 2025	4:30p	Training	Officer	Regular	8.5	0
Canfield, Alexander	Nov 13, 2025	8:00a	Nov 13, 2025	4:30p	Training	Officer	Regular	8.5	0
Canfield, Alexander	Nov 14, 2025	8:00a	Nov 14, 2025	4:30p	Training	Officer	Regular	8.5	0
SUBTOTAL:								32.50	0.00
Clemens, Justin	Nov 11, 2025	6:30a	Nov 11, 2025	9:30a	Training	Officer	OT - Training	3	0
Clemens, Justin	Nov 14, 2025	8:00a	Nov 14, 2025	4:30p	Training	Officer	Regular	8.5	0
Clemens, Justin	Nov 19, 2025	5:00p	Nov 19, 2025	9:00p	Training	Officer	OT - Training	4	0
SUBTOTAL:								15.50	0.00
Dalziel, Alexander	Nov 4, 2025	6:00a	Nov 4, 2025	10:00a	Training	Officer	Regular	4	0
Dalziel, Alexander	Nov 10, 2025	10:30a	Nov 10, 2025	1:30p	Training	Officer	Regular	3	0
SUBTOTAL:								7.00	0.00
Dorniden, Blake	Nov 11, 2025	10:30a	Nov 11, 2025	1:30p	Training	Officer	OT - Training	3	0
SUBTOTAL:								3.00	0.00
Farnsworth, Cody	Nov 10, 2025	10:30a	Nov 10, 2025	1:30p	Training	Officer	OT - Training	3	0
SUBTOTAL:								3.00	0.00
Hanna, James	Nov 11, 2025	10:30a	Nov 11, 2025	1:30p	Training	Officer	OT - Training	3	0
SUBTOTAL:								3.00	0.00
Hanson, Eric	Nov 10, 2025	7:30a	Nov 10, 2025	4:00p	Training	Comm.	Regular	8.5	0
Hanson, Eric	Nov 11, 2025	7:30a	Nov 11, 2025	4:00p	Training	Comm.	Regular	8.5	0
SUBTOTAL:								17.00	0.00
Jones, Matthew	Nov 4, 2025	5:30a	Nov 4, 2025	6:00a	Training	Officer	Regular	0.5	0
Jones, Matthew	Nov 4, 2025	6:00a	Nov 4, 2025	2:30p	Training	Officer	Regular	8.5	0
Jones, Matthew	Nov 10, 2025	10:30a	Nov 10, 2025	1:30p	Training	Officer	Regular	3	0
Jones, Matthew	Nov 14, 2025	8:00a	Nov 14, 2025	4:30p	Training	Officer	Regular	8.5	0
TOTAL:								551.50	34.50

Member	Shift Start Date	Shift Start Time	Shift Stop Date	Shift Stop Time	Schedule	Position	Time Type	Regular Hours	Overtime Hours
Jones, Matthew	Nov 19, 2025	5:00p	Nov 19, 2025	9:00p	Training	Officer	Regular	4	0
							SUBTOTAL:	24.50	0.00
Jones, Shawn	Nov 4, 2025	10:00a	Nov 4, 2025	2:00p	Training	Officer	Regular	4	0
Jones, Shawn	Nov 10, 2025	10:30a	Nov 10, 2025	1:30p	Training	Officer	Regular	3	0
							SUBTOTAL:	7.00	0.00
Kaminski, Daniel	Nov 5, 2025	8:00a	Nov 5, 2025	4:30p	Training	Officer	Regular	8.5	0
Kaminski, Daniel	Nov 6, 2025	8:00a	Nov 6, 2025	4:30p	Training	Officer	Regular	8.5	0
Kaminski, Daniel	Nov 7, 2025	8:00a	Nov 7, 2025	4:30p	Training	Officer	Regular	8.5	0
Kaminski, Daniel	Nov 11, 2025	10:30a	Nov 11, 2025	1:30p	Training	Officer	OT - Training	3	0
Kaminski, Daniel	Nov 14, 2025	8:00a	Nov 14, 2025	4:30p	Training	Officer	Regular	8.5	0
Kaminski, Daniel	Nov 19, 2025	5:00p	Nov 19, 2025	9:00p	Training	Officer	OT - Training	3	1
							SUBTOTAL:	40.00	1.00
Kloety, Kyle	Nov 4, 2025	10:00a	Nov 4, 2025	2:00p	Training	Officer	OT - Training	4	0
Kloety, Kyle	Nov 10, 2025	10:30a	Nov 10, 2025	1:30p	Training	Officer	OT - Training	3	0
							SUBTOTAL:	7.00	0.00
Kuchta, Nicholas	Nov 4, 2025	6:00a	Nov 4, 2025	10:00a	Training	Officer	OT - Training	4	0
Kuchta, Nicholas	Nov 5, 2025	8:00a	Nov 5, 2025	4:30p	Training	Officer	Regular	8.5	0
Kuchta, Nicholas	Nov 6, 2025	8:00a	Nov 6, 2025	4:30p	Training	Officer	Regular	8.5	0
Kuchta, Nicholas	Nov 7, 2025	8:00a	Nov 7, 2025	4:30p	Training	Officer	Regular	8.5	0
Kuchta, Nicholas	Nov 10, 2025	6:30a	Nov 10, 2025	9:30a	Training	Officer	OT - Training	3	0
							SUBTOTAL:	32.50	0.00
Laux, Kevin	Nov 4, 2025	10:00a	Nov 4, 2025	2:00p	Training	Officer	OT - Training	4	0
Laux, Kevin	Nov 11, 2025	10:30a	Nov 11, 2025	1:30p	Training	Officer	Regular	3	0
							SUBTOTAL:	7.00	0.00
Lembke, Aaron	Nov 11, 2025	6:30a	Nov 11, 2025	9:30a	Training	Officer	Regular	3	0
							SUBTOTAL:	3.00	0.00
Majkowski, Brock	Nov 11, 2025	10:30a	Nov 11, 2025	1:30p	Training	Officer	OT - Training	3	0
Majkowski, Brock	Nov 14, 2025	8:00a	Nov 14, 2025	4:30p	Training	Officer	Regular	8.5	0
Majkowski, Brock	Nov 19, 2025	5:00p	Nov 19, 2025	9:00p	Training	Officer	Regular	4	0
							SUBTOTAL:	15.50	0.00
Mikulec, Daniel	Nov 4, 2025	6:00a	Nov 4, 2025	10:00a	Training	Officer	Regular	4	0
							SUBTOTAL:	4.00	0.00
Nisiewicz, Thomas	Nov 11, 2025	6:30a	Nov 11, 2025	9:30a	Training	Officer	OT - Training	3	0
							SUBTOTAL:	3.00	0.00
Nolan, Kelly	Nov 10, 2025	7:30a	Nov 10, 2025	4:00p	Training	Comm.	Regular	8.5	0
Nolan, Kelly	Nov 11, 2025	7:30a	Nov 11, 2025	4:00p	Training	Comm.	Regular	8.5	0
							SUBTOTAL:	17.00	0.00
Olson, Toni	Nov 10, 2025	10:30a	Nov 10, 2025	1:30p	Training	Officer	Regular	3	0
							SUBTOTAL:	3.00	0.00
Onela, Michael	Nov 4, 2025	6:00a	Nov 4, 2025	10:00a	Training	Officer	Regular	4	0
Onela, Michael	Nov 10, 2025	6:30a	Nov 10, 2025	9:30a	Training	Officer	Regular	3	0
							SUBTOTAL:	7.00	0.00
Pabich, Daniel	Nov 11, 2025	6:30a	Nov 11, 2025	9:30a	Training	Officer	Regular	3	0
							SUBTOTAL:	3.00	0.00
Pesch, Justin	Nov 5, 2025	8:00a	Nov 5, 2025	4:30p	Training	Supervisor	Regular	8.5	0
Pesch, Justin	Nov 6, 2025	8:00a	Nov 6, 2025	4:30p	Training	Supervisor	Regular	8.5	0
							TOTAL:	551.50	34.50

Member	Shift Start Date	Shift Start Time	Shift Stop Date	Shift Stop Time	Schedule	Position	Time Type	Regular Hours	Overtime Hours
Pesch, Justin	Nov 7, 2025	8:00a	Nov 7, 2025	4:30p	Training	Supervisor	Regular	8.5	0
Pesch, Justin	Nov 10, 2025	6:30a	Nov 10, 2025	9:30a	Training	Officer	Regular	3	0
SUBTOTAL:								28.50	0.00
Peterson, Jeremy	Nov 4, 2025	6:00a	Nov 4, 2025	10:00a	Training	Officer	OT - Training	4	0
Peterson, Jeremy	Nov 10, 2025	6:30a	Nov 10, 2025	9:30a	Training	Officer	OT - Training	3	0
SUBTOTAL:								7.00	0.00
Preisler, Andrew	Nov 4, 2025	10:00a	Nov 4, 2025	2:00p	Training	Officer	OT - Training	4	0
Preisler, Andrew	Nov 10, 2025	10:30a	Nov 10, 2025	1:30p	Training	Officer	OT - Training	3	0
Preisler, Andrew	Nov 12, 2025	8:00a	Nov 12, 2025	4:30p	Training	Officer	Regular	8.5	0
Preisler, Andrew	Nov 13, 2025	8:00a	Nov 13, 2025	4:30p	Training	Officer	Regular	8.5	0
Preisler, Andrew	Nov 14, 2025	8:00a	Nov 14, 2025	4:30p	Training	Officer	Regular	8.5	0
SUBTOTAL:								32.50	0.00
Rechlicz, Justin	Nov 11, 2025	6:30a	Nov 11, 2025	9:30a	Training	Officer	Regular	3	0
SUBTOTAL:								3.00	0.00
Roecker, Jacob	Nov 5, 2025	8:00a	Nov 5, 2025	4:30p	Training	Officer	Regular	8.5	0
Roecker, Jacob	Nov 6, 2025	8:00a	Nov 6, 2025	4:30p	Training	Officer	Regular	8.5	0
Roecker, Jacob	Nov 7, 2025	8:00a	Nov 7, 2025	4:30p	Training	Officer	Regular	8.5	0
Roecker, Jacob	Nov 11, 2025	6:30a	Nov 11, 2025	9:30a	Training	Officer	OT - Training	3	0
SUBTOTAL:								28.50	0.00
Schmittinger, Jayna	Nov 4, 2025	10:00a	Nov 4, 2025	2:00p	Training	Officer	Regular	4	0
Schmittinger, Jayna	Nov 10, 2025	10:30a	Nov 10, 2025	1:30p	Training	Officer	Regular	3	0
SUBTOTAL:								7.00	0.00
Schulz, Zach	Nov 4, 2025	10:00a	Nov 4, 2025	2:00p	Training	Officer	Regular	4	0
Schulz, Zach	Nov 10, 2025	6:00a	Nov 10, 2025	2:30p	Training	Officer	Regular	8.5	0
Schulz, Zach	Nov 11, 2025	6:00a	Nov 11, 2025	2:30p	Training	Officer	Regular	8.5	0
Schulz, Zach	Nov 13, 2025	8:00a	Nov 13, 2025	4:30p	Training	Officer	Regular	8.5	0
SUBTOTAL:								29.50	0.00
Spreiter, Jared	Nov 4, 2025	10:00a	Nov 4, 2025	2:00p	Training	Officer	OT - Training	4	0
Spreiter, Jared	Nov 5, 2025	8:00a	Nov 5, 2025	4:30p	Training	Officer	Regular	8.5	0
Spreiter, Jared	Nov 6, 2025	8:00a	Nov 6, 2025	4:30p	Training	Officer	Regular	8.5	0
Spreiter, Jared	Nov 7, 2025	8:00a	Nov 7, 2025	4:30p	Training	Officer	Regular	8.5	0
Spreiter, Jared	Nov 10, 2025	10:30a	Nov 10, 2025	1:30p	Training	Officer	OT - Training	3	0
Spreiter, Jared	Nov 12, 2025	8:00a	Nov 12, 2025	4:30p	Training	Officer	Regular	7.5	1
Spreiter, Jared	Nov 13, 2025	8:00a	Nov 13, 2025	4:30p	Training	Officer	Regular	0	8.5
Spreiter, Jared	Nov 14, 2025	8:00a	Nov 14, 2025	4:30p	Training	Officer	Regular	0	8.5
Spreiter, Jared	Nov 19, 2025	5:00p	Nov 19, 2025	9:00p	Training	Officer	OT - Training	0	4
SUBTOTAL:								40.00	22.00
Von Bereghy, Darren	Nov 4, 2025	6:00a	Nov 4, 2025	2:30p	Training	Officer	Regular	8.5	0
Von Bereghy, Darren	Nov 5, 2025	8:00a	Nov 5, 2025	4:30p	Training	Supervisor	Regular	8.5	0
Von Bereghy, Darren	Nov 6, 2025	8:00a	Nov 6, 2025	4:30p	Training	Supervisor	Regular	8.5	0
Von Bereghy, Darren	Nov 7, 2025	8:00a	Nov 7, 2025	4:30p	Training	Supervisor	Regular	8.5	0
Von Bereghy, Darren	Nov 14, 2025	8:00a	Nov 14, 2025	4:30p	Training	Officer	Regular	6	2.5
Von Bereghy, Darren	Nov 19, 2025	5:00p	Nov 19, 2025	9:00p	Training	Officer	Regular	0	4
SUBTOTAL:								40.00	6.50
TOTAL:								551.50	34.50

Member	Shift Start Date	Shift Start Time	Shift Stop Date	Shift Stop Time	Schedule	Position	Time Type	Regular Hours	Overtime Hours
Whealon, Shaun	Nov 4, 2025	6:00a	Nov 4, 2025	10:00a	Training	Officer	Regular	4	0
Whealon, Shaun	Nov 11, 2025	6:30a	Nov 11, 2025	9:30a	Training	Officer	Regular	3	0
SUBTOTAL:								7.00	0.00
Wroblewski, Tyler	Nov 4, 2025	6:00a	Nov 4, 2025	10:00a	Training	Officer	OT - Training	4	0
Wroblewski, Tyler	Nov 10, 2025	6:30a	Nov 10, 2025	9:30a	Training	Officer	OT - Training	3	0
SUBTOTAL:								7.00	0.00
TOTAL:								551.50	34.50

November 2025 Training

- Wrap Safety Training – Multiple
- Decoy Training – Kuchta, Kaminski, Roecker, Anjum
- WI Public Records Laws – Hanson, Nolan
- Firearms/Low Light shooting – All
- Field Training Officer Basic – Spreiter, Preisler, Canfield
- Leadership Germantown – Bartelt, Schulz
- SWAT – VonBereghy, Anjum, Bartelt, M Jones, Kaminski, Majkowski, Clemens
- SWAT Shoot – VonBereghy, Majkowski, M Jones, Kaminski, Clemens, Bartelt, Anjum

2025 POLICE UNION OT

	OT HRS	OT PAID	COMP HRS	OT COMP
JAN	99.00	\$ 6,650.67	77.50	\$5,075.37
FEB	95.25	6,234.14	82.25	5,499.99
MAR	129.50	8,599.47	74.00	4,822.09
APR	229.50	15,066.37	99.00	6,610.65
MAY	258.50	16,992.72	100.50	7,057.41
JUN	363.50	24,150.12	199.00	12,228.79
JUL	404.75	26,292.02	223.50	14,499.44
AUG	204.50	12,843.64	117.50	7,752.56
SEP	164.50	9,786.32	97.25	6,423.61
OCT	219.25	13,667.49	80.00	5,183.08
NOV	239.00	15,315.73	74.75	4,636.98
DEC	320.75	19,393.41	137.00	8,904.75
TOTAL	2,728.00	\$ 174,992.08	1,362.25	\$ 88,694.71

2025 POLICE SGT OT

	OT HRS	OT PAID	COMP HRS	OT COMP
JAN	112.50	\$ 8,370.81	7.75	\$576.66
FEB	83.00	6,175.80	23.00	1,711.37
MAR	51.00	3,794.77	46.25	3,441.33
APR	58.00	4,315.62	27.25	2,027.60
MAY	77.00	5,729.35	36.75	2,734.46
JUN	101.50	7,552.33	48.00	3,571.55
JUL	83.50	6,213.00	30.00	2,232.22
AUG	79.50	5,915.37	17.75	1,320.73
SEP	58.75	4,371.42	47.75	3,552.94
OCT	48.25	1,878.78	18.75	1,246.32
NOV	60.00	4,464.43	37.00	2,753.07
DEC	103.25	7,682.54	25.25	1,878.78
TOTAL	916.25	\$ 66,464.23	365.50	\$27,047.02

BUSINESS OF THE PUBLIC SAFETY COMMITTEE

MEETING DATE: January 5, 2026

PLACEMENT: Action Item

ITEM TITLE: Rifle Suppressor purchase for 25 rifles (ACTION)

SUBMITTED BY: Patrick Merten, Police Chief

SUMMARY EXPLANATION:

ATTACHMENT:

1. Rifle Suppressors
2. Suppressor Quote

STAFF RECOMMENDATION:

ACTION BY COMMITTEE:

**BUSINESS OF THE PUBLIC SAFETY COMMITTEE
GERMANTOWN, WI**

MEETING DATE: January 5, 2026

AGENDA ITEM: Action

ITEM TITLE: Rifle Suppressor Purchase

SUBMITTED BY: Chief Patrick Merten

SUMMARY EXPLANATION:

The Germantown Police Department is seeking approval to purchase 25 firearm suppressors for patrol rifles. After evaluating and testing several suppressor manufacturers, the department selected Dead Air Silencers as the preferred vendor based on performance and reliability.

The total estimated cost of this purchase is \$18,475.00, which has been budgeted in the FY 2026 Police Administration – Capital Expenditure account.

This investment will enhance officer and civilian safety by reducing noise exposure and improving communication during critical incidents, lower long-term liability related to hearing damage, and ensure the department remains aligned with best practices in modern law enforcement.

ATTACHMENT: ORDINANCE___ RESOLUTION_____ OTHER__X__

RECOMMENDATION:

A motion to recommend approval to proceed with the purchase of 25 rifle suppressors.



Quote

Date 11/24/2025 **Order#** EST176

Bill To

Germantown Police Department
N112W16877 Mequon Road
Germantown WI 53022
United States

TOTAL
\$18,475.00
Expires: 2/24/2026

Expires	Exp. Close	Sales Rep	Partner	Shipping Method
2/24/2026	11/24/2025			

Item	Description	Quantity	Unit Price	Ext Amount
LZ6XNBLK	Dead Air Lazarus 6 5.56/6MM GMS™ Low Back Pressure Silencer in w/ Xeno Adapter & DA129 1/2-28 Xeno 3Prong FH	25	\$739.00	\$18,475.00

Subtotal	\$18,475.00
Tax Total (0%)	\$0.00
Total	\$18,475.00



BUSINESS OF THE PUBLIC SAFETY COMMITTEE

MEETING DATE: January 5, 2026

PLACEMENT: Action Item

ITEM TITLE: ProPhoenix Records Management Maintenance and Support for 2026 (ACTION)

SUBMITTED BY: Patrick Merten, Police Chief

SUMMARY EXPLANATION:

ATTACHMENT:

1. ProPhoenix - Agenda item
2. ProPhoenix Support Invoice- 2026

STAFF RECOMMENDATION:

ACTION BY COMMITTEE:

**BUSINESS OF THE PUBLIC SAFETY COMMITTEE
GERMANTOWN, WI**

MEETING DATE: January 5, 2026

AGENDA ITEM: Action

ITEM TITLE: ProPhoenix Maintenance Contract for 2026

SUBMITTED BY: Chief Patrick Merten

SUMMARY EXPLANATION:

ProPhoenix is the Germantown Police Department's records management system. The software supports the documentation and management of names, businesses, calls for service, complaints, citations, arrests, and numerous other functions essential to daily police operations.

This maintenance agreement covers the ProPhoenix records management system and the Morpho Touch Interface, both of which are used daily by department personnel.

Funding for this agreement has been budgeted in the 2026 fiscal year under PD IT Maintenance, account number 10541000_531300, in the amount of \$23,091.94.

ATTACHMENT: ORDINANCE___ RESOLUTION_____ OTHER__X__

RECOMMENDATION:

A motion to recommend approving the ProPhoenix maintenance contract for year 2026.

2024

ProPhoenix Corporation

502 Pleasant Valley Ave, Ste 1
Moorestown, NJ 08057
Phone # 609-953-6850
Web: www.prophoenix.com

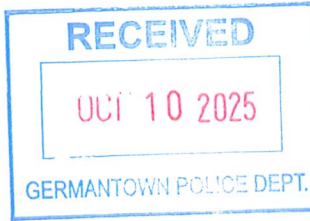

Invoice

Bill To
Germantown PD N112W16877 Mequon Rd Germantown, WI 53022 Attn: Julie Barth Email: jbarth@germantownpolice.org

Date	Invoice #	Invoice Amount
10/10/2025	2026016	\$23,091.94
P.O. No.	Terms	Due Date
	Due date	1/1/2026

Item	Description	Qty	Rate	Amount
PNX-ASM	Phoenix Annual Maintenance and Support - RMS	1	22,281.10	22,281.10
PNX-ASM	Morpho Touch Interface Maintenance Period: 01/01/26 - 12/31/26	1	810.84	810.84

Total		\$23,091.94
--------------	--	-------------

Tax ID	20-5731095
--------	------------

Please make checks payable to "ProPhoenix".
For Billing inquiries, please contact Rachele Negri (rachele.negri@prophoenix.com) or Paul Hoppe (paul.hoppe@prophoenix.com). It's been a pleasure working with you!

Payments/Credits	\$0.00
Balance Due	\$23,091.94

BUSINESS OF THE PUBLIC SAFETY COMMITTEE

MEETING DATE: January 5, 2026

PLACEMENT: Action Item

ITEM TITLE: Lexipol Policy Management Support for 2026 (ACTION)

SUBMITTED BY: Patrick Merten, Police Chief

SUMMARY EXPLANATION:

ATTACHMENT:

1. Lexipol - Agenda item
2. Lexipol Support - 2026

STAFF RECOMMENDATION:

ACTION BY COMMITTEE:

**BUSINESS OF THE PUBLIC SAFETY COMMITTEE
GERMANTOWN, WI**

MEETING DATE: January 5, 2026

AGENDA ITEM: Action

ITEM TITLE: Lexipol Policy Management subscription for 2026

SUBMITTED BY: Chief Patrick Merten

SUMMARY EXPLANATION:

Lexipol is a policy management software that enables the Germantown Police Department to maintain standardized policies that remain current with legislative and regulatory changes. The system also delivers training to officers through daily policy and training bulletins, ensuring ongoing compliance and awareness.

Funding for Lexipol Policy Management has been budgeted for the 2026 fiscal year under PD Training, account number 10541000_531080, in the amount of \$18,816.87.

ATTACHMENT: ORDINANCE___ RESOLUTION____ OTHER__X__

RECOMMENDATION:

A motion to recommend approving the Lexipol subscription for year 2026.

Adm. Sec. Julie Barth

From: noreply@salesforce.com on behalf of Customer Success Aid
<customersuccessaid@lexipol.com>
Sent: Monday, November 3, 2025 8:01 AM
To: Adm. Sec. Julie Barth
Subject: Lexipol Notice: Your Contract will Renew in 90 Days

**CAUTION: This email originated from outside the organization.
Do not click links or open attachments unless you recognize the sender and know the content is safe.**

Thank you for being a Lexipol customer!

Your subscription will renew soon.

You make difficult decisions every day, including how and where you invest your agency's finite resources. We are honored to support the vital work you do, and we work tirelessly to make your continued partnership with Lexipol the easiest decision you make.

At our core is our continued commitment to delivering best practice guidance essential to a high-performing agency. Last year, Lexipol helped agencies maintain compliance with more than 14,000 legislative and regulatory changes affecting public safety. We also introduced 111 new online training courses to keep personnel up to date on changing tactics and strategies, and over 250 new wellness resources on topics ranging from retirement preparation to mindfulness, leadership and resilience.

We are making significant investments to:

- Bring you unparalleled insight into critical areas of operations – including trends, insights and risks
- Deliver tools that reduce complexity and lighten the administrative burden of evolving accreditation and certification requirements
- Broaden our Training solution to support personnel from hire to retire, including new short-form videos and supplemental materials on timely topics and best practices
- Equip you with resources to build a lasting wellness program that puts your people first and reduces burnout and turnover

We recently shared the news that we're rolling out our next-generation policy management platform, designed to make your work smoother, faster and more collaborative than ever before. In the words of our co-founder, Gordon Graham:

"Every enhancement in Lexipol's new policy management platform was shaped by real input from Lexipol's users. This is not just an upgrade. It's a complete reimagining built with your needs in mind. You'll have access to modernized tools from day one with ongoing enhancements and new features delivered regularly, guided by your feedback."

Beyond policy management, the new platform forms the basis of a unified software experience across Policy, Training, Reports and Wellness that will help you and your personnel seamlessly access the resources you need when you need them.

If you have any questions, your customer success manager is always available to help you get the most from your Lexipol solutions.

Lexipol is proud to play a role in the incredible work public safety professionals do every day. Thank you for the continued opportunity to support you, your personnel and your mission.

Your contract for the Account of Germantown Police Department in the amount of **\$18,816.87**, will renew on February 1, 2026.

Product	Quantity	Sales Price
Annual Law Enforcement Supplemental Manual(s)	1	\$1,649.58
Annual Law Enforcement Policy Manual & Daily Training Bulletins	1	\$15,211.00
Law Enforcement Accreditation Workbench Premium	1	\$1,956.29

Applicable taxes will be added for customers in Arizona, South Carolina, Washington & Tennessee unless Lexipol has a valid exemption certificate on file. All other states will be subject to applicable taxes in the future.

Please let us know if you have any questions.

Sincerely,

Customer Success Team | customersuccessaid@lexipol.com

BUSINESS OF THE PUBLIC SAFETY COMMITTEE

MEETING DATE: January 5, 2026

PLACEMENT: Action Item

ITEM TITLE: GFD Staff Command Vehicle Purchase (ACTION)

SUBMITTED BY:

SUMMARY EXPLANATION:

ATTACHMENT:

1. Germantown FSD Command Proposal r4 12-17-25
2. Public Safety Command Vehicle
3. Q00541_1 Germantown FSD Command r4

STAFF RECOMMENDATION:

ACTION BY COMMITTEE:



37241 E Richardson Ln
 Purcellville, VA 20132
 (877) 327-8526
sales@flev.com
www.flev.com

FORMAL PROPOSAL

Proposal Date: December 17, 2025

Prepared for: Ryker Holms
 Germantown Fire Department
 N115 W18752 Edison Drive
 Germantown, WI 53022

For your consideration, the listed herein is valid for a period of no more than 60 days from the above date (unless listed otherwise). FastLane is not responsible for price changes of goods or products not directly manufactured by FastLane Emergency Vehicles. Only items below shall be considered "part of this proposal". As is all information you share with us, we ask that you and/or your organization please retain this information as confidential. Please review the following information. If all items are acceptable, please forward over a Purchase Order with your preferred payment terms option, as listed above. We look forward to doing business with you. Should you require any clarification or have any questions, please do not hesitate to reach out.

Description: Conversion of FL-supplied Ford F250 for command purposes.

DETAILS	TOTAL PROJECT COST
Conversion upfit on vehicle of type: F250 <i>As outlined in accompanying Build Specifications document (includes vehicle if FastLane is supplying)</i>	\$140,116
Purchasing Contract Option: HGAC	\$1,000
TOTAL CONTRACT AMOUNT	\$141,116

Vehicle/Chassis Details

FastLane Supplied? YES	Type: F250
-------------------------------	-------------------

Reflected in the total project cost above for your review:

Vehicle MSRP.....	\$65835
Less Chassis Concession.....	\$
Vehicle Net.....	\$65,835

Pricing here-in reflects FastLane standard terms of **Deposit & Cash on Delivery** of completed unit. Other terms and discounts apply and can be provided upon request.

Pricing Terms:

Current Lead Time: 90-120 Days after receipt of order.

Respectfully Submitted: Drew Crisp

Thank you for this opportunity. I am confident that once you have had a chance to review the contents within, you will share our opinion that FastLane is the best choice for your department's needs.



37241 E Richardson Ln
Purcellville, VA 20132
(877) 327-8526
sales@flev.com
www.flev.com

FORMAL PROPOSAL

**Terms Details: If FastLane is to supply the vehicle as part of this project, we can neither guarantee the model year nor pricing of the vehicle proposed. Recent events have caused both Ford and GM to cancel and reject chassis orders all together. FastLane will confirm model year and pricing once the order is submitted to the vehicle manufacturer and remain in continuous contact with the customer with any changes or updates. If this proposal includes an in-stock chassis provided by FastLane, full payment of the chassis is due within 15 days after receipt of order to ensure accuracy of the price quoted and to secure the vehicle for upfit. Title and ownership of the vehicle will be transferred to the customer once payment has cleared and paperwork received from manufacturer. If terms include deposit/COD the deposit amount of 25% of the Total Project Cost (not to include the Vehicle Net price) is due within 15 days after receipt of order.*

BUSINESS OF THE PUBLIC SAFETY COMMITTEE

MEETING DATE: January 5, 2026

PLACEMENT: Action Item

ITEM TITLE: Staff Command Vehicle Purchase

SUBMITTED BY: John Delain, Fire Chief

SUMMARY EXPLANATION:

Staff are recommending the Public Safety Committee approve the purchase of an upfitted command operations staff vehicle from Fastlane Emergency Vehicles in the amount of \$141,116. Staff were able to obtain approximately \$10,000 (already factored) in cost savings through a government group purchasing contract. This amount includes the vehicle and emergency upfitting equipment excluding radios and equipment that require local programming prior to installation (HAAS System, Knoxbox, Cell-Boost, etc). **Customer supplied equipment estimated cost is \$25,000.**

If this vehicle receives proper approvals by the Public Safety Committee and subsequently the Village Board by February 2026, FastLane has agreed to honor their 2025 quoted price. FastLane has given a delivery timeline of 90-120 days from time of order.

The Public Safety Committee and Village Board approved \$275,000 in the 2026 budget process to be used for 2 vehicles and upfit equipment. Staff will bring forward the 2nd vehicle in a future meeting, we are waiting for updated quotes. The 2nd vehicle will not have as much upfitting cost due to being a less specialized use.

The vehicle will replace the current staff vehicle. That vehicle is a Ford Explorer and will be repurposed and used as an inspection and staff vehicle. One of our 2 daytime inspectors currently drives our 2012 brush truck, which is not ideal for on-road use. It is also putting undue wear and tear on our brush truck as it is outfitted for off-road driving.

This vehicle will be staffed 24/7 Chief and responds to high-acuity EMS calls, motor vehicle accidents, fire alarms, carbon monoxide alarms, hazardous materials, natural disasters, fires (house, business, vehicle), tactical situations, search and rescue, technical rescue (high-angle/confined space), and mutual aid for a total around 1,200 emergency responses annually. In addition to the emergency uses the vehicle also is used daily for staff functions such as meetings, training, school, investigations, and public education.

Why is specialized equipment needed? *Note: This is not a comprehensive list but covers most of the major items.*

- **Mobile / Portable Radios**
 - This vehicle will be outfitted with multiple mobile and portable radios. On every call GFD crews operate on a minimum of 2 radio channels. On most non-EMS calls GFD crews must operate at least 3 radio channels. Having multiple radios allows for the incident commander to simultaneously listen and talk to the different channels. Having this ability is critical for the safety of the responders.
- **Cardiac Monitor & minimal EMS equipment**
 - Due to being a smaller vehicle and occasionally being at other locations this vehicle can often arrive first on scene to most calls. Keeping this equipment on the vehicle allows the Battalion Chief to immediately begin rendering aid to EMS patients. This could be CPR or administering Epi to someone experiencing an allergic reaction.
- **Fire Extinguishers**
 - Fire doubles in size every 60 seconds, rapid and skilled application of an extinguishing agent on a fire can be the difference between containing a fire to 1 room or losing an entire floor.
- **White Boards / Command Boards**
 - The white boards are used for the incident commander to keep track of times, people's locations, strategies, tactics, hazards, pre-plans etc. These boards incorporate our accountability system. The accountability system is a manual system of Velcro name plates that is used to track each crew's assignment and location. This way if an emergency occurs the incident commander can direct resources to the correct location.
- **Rapid Intervention Team (RIT) Pack**
 - This pack contains most of the necessary equipment if a firefighter experiences an emergency while fighting fire. Some of the equipment is an extra air-bottle, cutting equipment, extra facemask, buddy-breathing (share an air bottle), rescue rope, and more. Not all apparatus carry a RIT pack, and most incidents requiring a RIT crew occur within the first 10 minutes of arriving on scene. Having this available during that time ensures we have the required equipment to get our members out if needed.
- **Tablet / iPad**
 - The iPad is used for apparatus tracking, computer aided dispatch, mapping, aerial views, accountability, document storage, and more. Each vehicle is outfitted with an iPad as it is required for the county dispatch to track times and for crews to receive pertinent information. The iPad in this vehicle is detachable and usable for other important tasks as well.
- **Lights / Siren**
 - Emergency vehicles must meet a minimum standard for emergency lights and sirens. A large portion of our incidents occur during dusk/night or in areas that are poorly lit. The lighting on this vehicle, once on scene, can operate as additional white scene lighting (flood light). This technology

has been incorporated onto our fire apparatus for at least the last decade and has proven to be important during low-light operations.

- This vehicle will be equipped with a HAAS system, which goes above the minimum requirements. This system notifies drivers emergency vehicles approaching or of an emergency scene ahead. This greatly improves responder safety as vehicles are being made to block out the external noises. Germantown was one of the first departments in the area to adopt this technology, and since then multiple other departments have implemented it as well.
- **Personal Protective Equipment / Self Contained Breathing Apparatus (PPE / SCBA)**
 - Our PPE ensemble consists of boots, pants, belt / suspenders, coat, hood, structural gloves, extrication gloves, helmet, facepiece, SCBA (air tank). All this equipment must be well cared for as it is our only defense between the smoke and fire. It must also have space to be carried in the vehicle generally away from other cloth materials to prevent spreading cancer-causing carcinogens. This truck is designed with space in the covered bed portion for PPE storage to keep the cab portion “clean”.
- **Organizer / Cabinets**
 - Efficient and organized access to our equipment ensures that we will be able to quickly utilize the equipment needed on the emergency scene. FastLane vehicles tailors each storage cabinet to the equipment that the respective departments carry. The 3 storage cabinets for this vehicle have been modified to ensure that the equipment being carried will fit and be readily accessible.
 - The other major benefit to these cabinets is they provide protection to our equipment. Our EMS monitor for example costs \$60,000, ensuring that the monitor has a well-fitted and secure area helps to guarantee that the monitor will be in good working order for many years.
- **Graphics**
 - This vehicle will be marked in a similar fashion to our other apparatus which is generally a gray stripe down each side, gold colored number / vehicle name or identifier, the department patch, and reflective chevron on the rear. For the multitude of functions that this vehicle will serve a marked vehicle is best. Marked vehicles increase public recognition, and in certain instances can increase responder safety from higher visibility.
- **Miscellaneous Equipment**
 - In addition to the larger items outlined above, there are several smaller pieces of equipment that can add up when outfitting an emergency vehicle. Some of those are KnoxBox, Sensit Quad-Gas, Auto-Eject Shoreline, Antenna Boosters, Cradlepoint, and others. These items are standard in our apparatus, they each play an important role in our daily operations. As an example, our KnoxBox system allows the department to enter participating buildings without damaging the property in the event of an emergency. This system alone has saved businesses in the Village tens of thousands of dollars.

Staff attempted to receive additional bids for this project; contacting 3 other vendors directly, however none of the other vendors submitted a bid meeting the requirements. This is likely due to the specialization of the vehicle that other upfitters are unable to complete to the same standard. For reference of complexity, there is an estimated 3-4 miles of wiring in one of these vehicles.

Photos of similar vehicles that FastLane has completed are included below to show complexity of build. <https://flev.com/deliveries/> for additional examples.



Examples of similar vehicles / equipment

Examples of similar vehicles / equipment

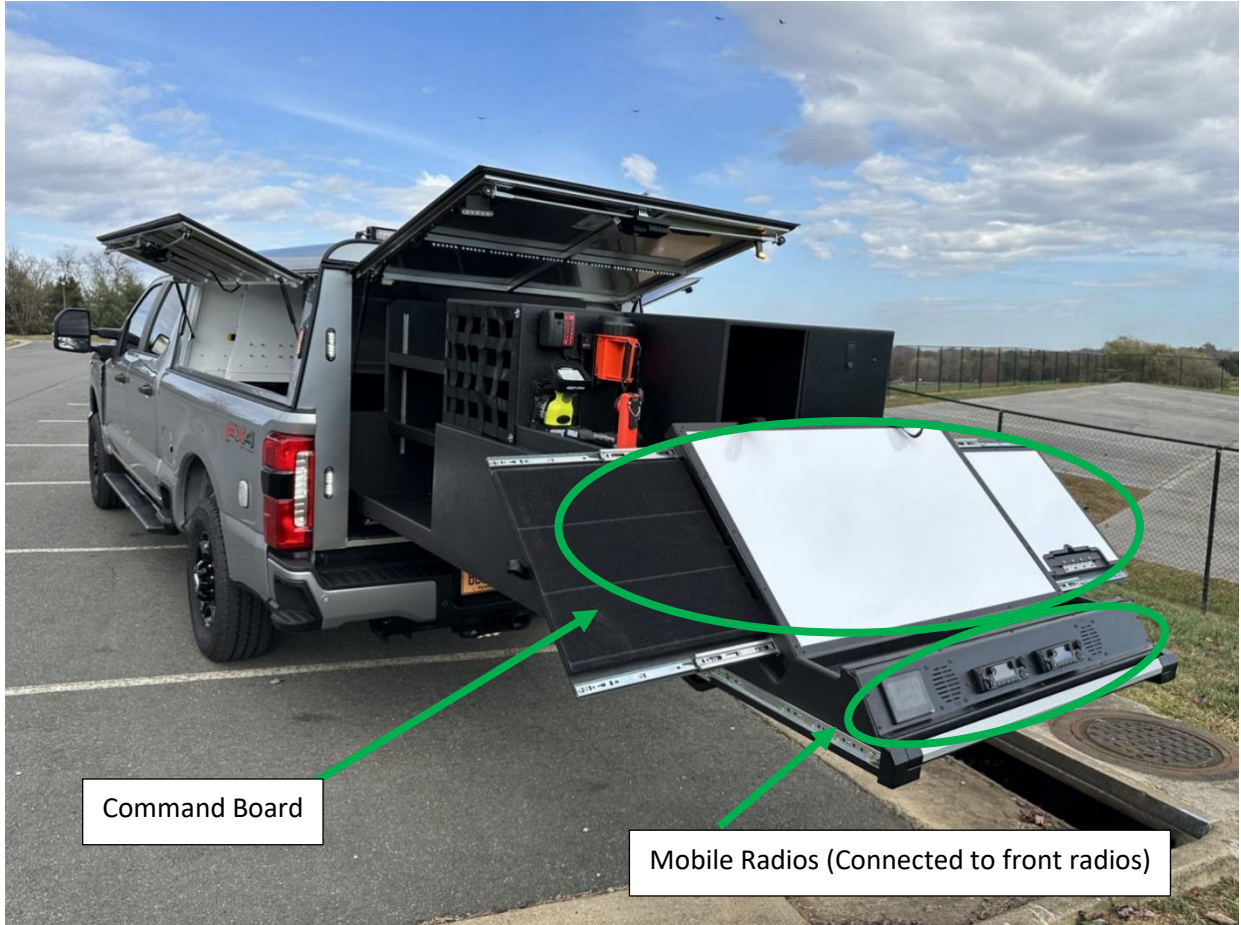

Examples of similar vehicles / equipment

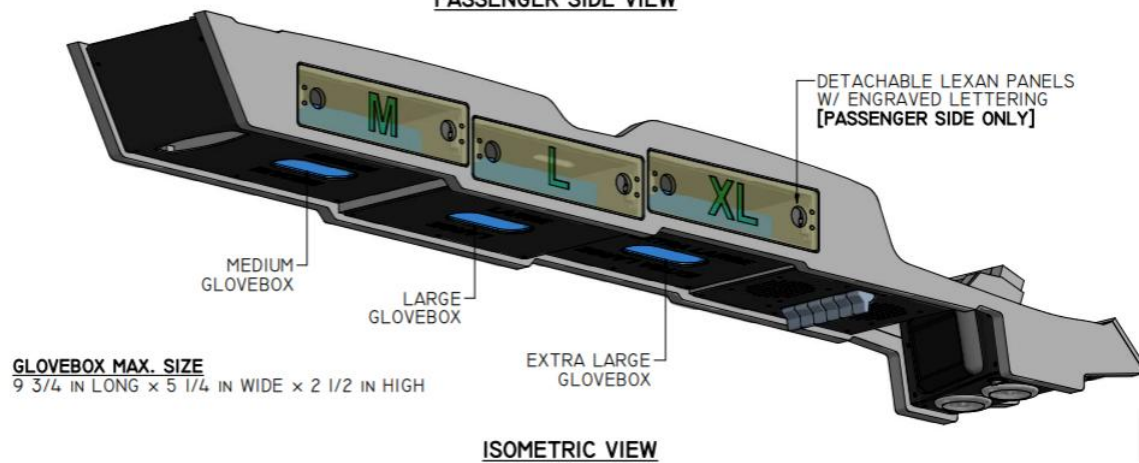
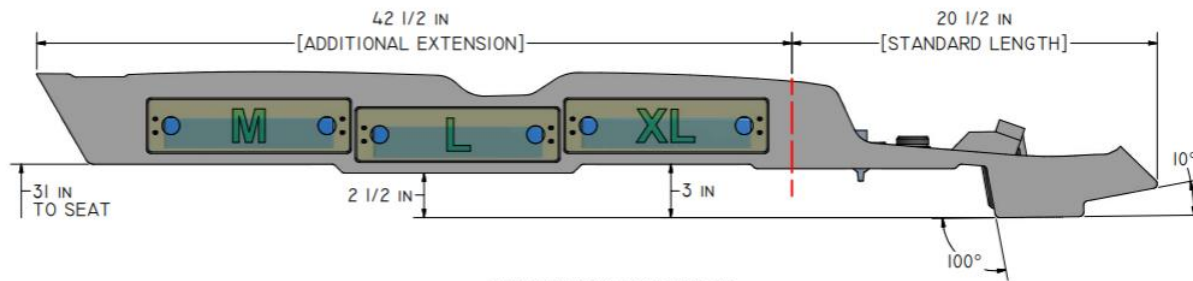
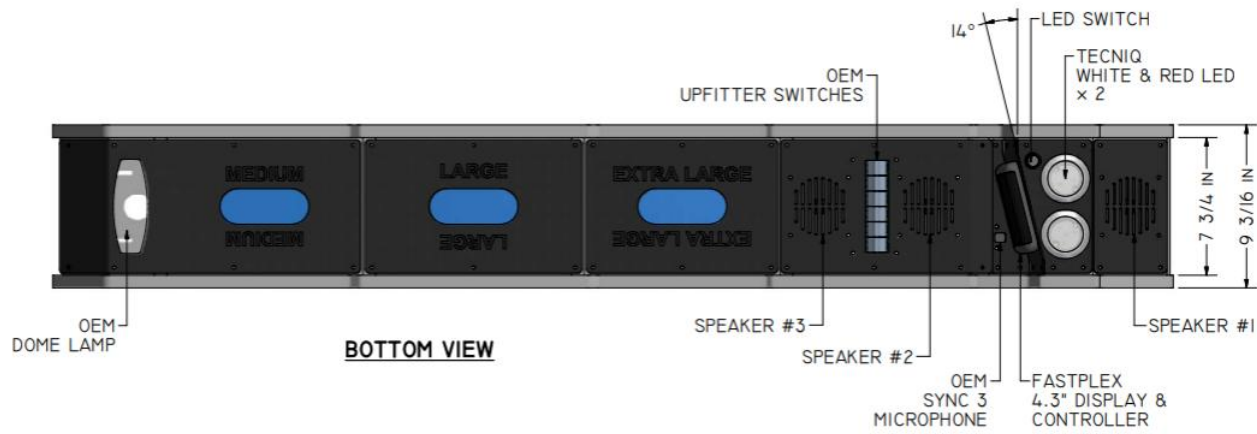

Examples of similar vehicles / equipment

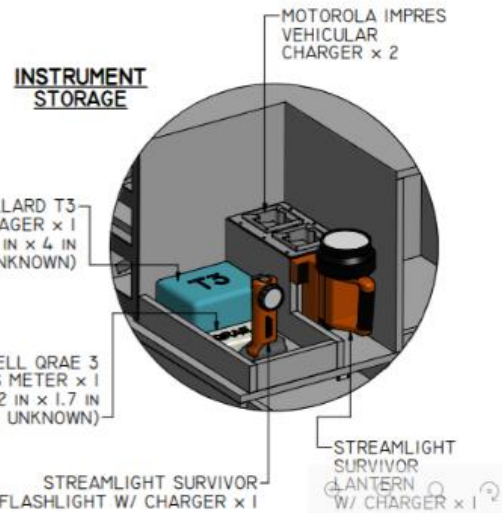
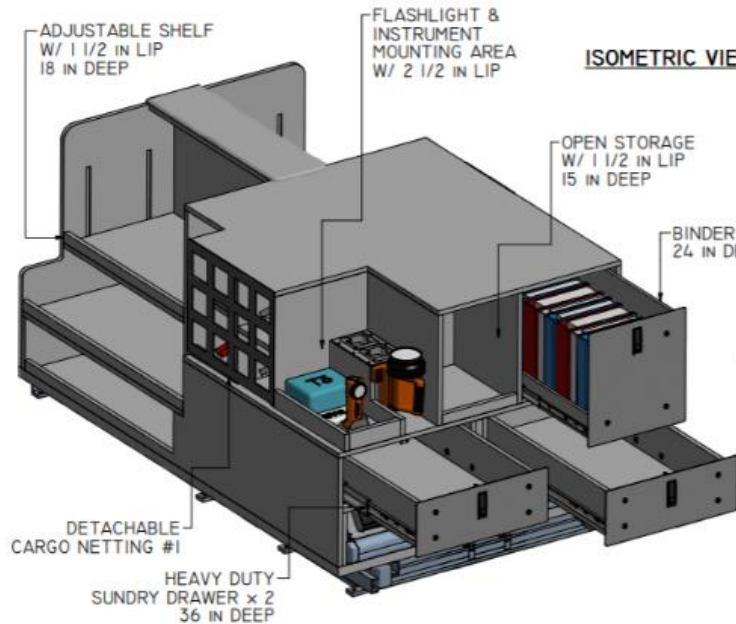
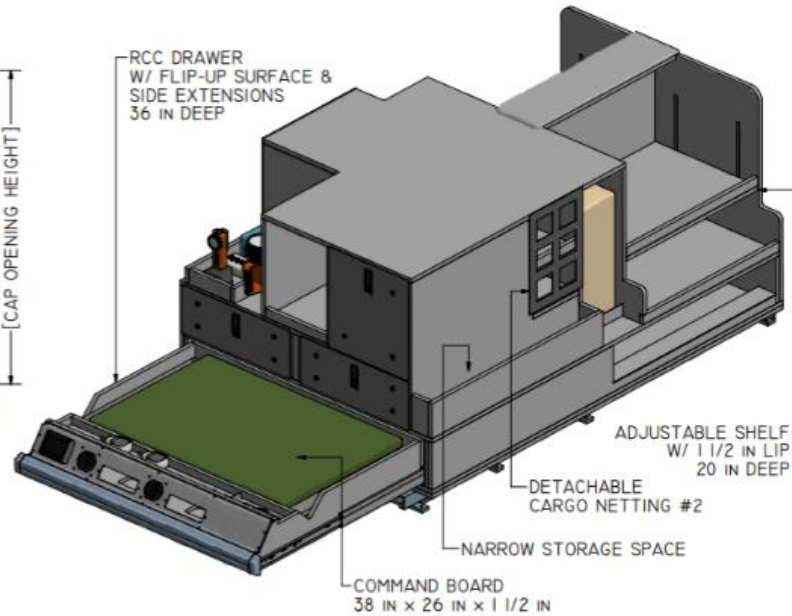
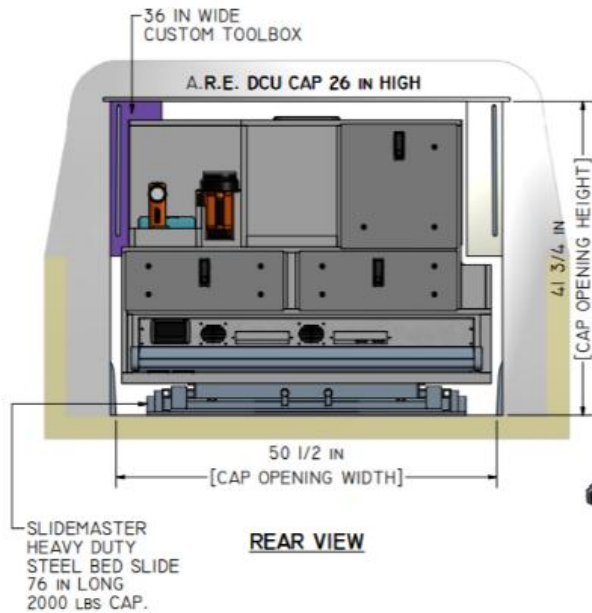

Examples of similar vehicles / equipment

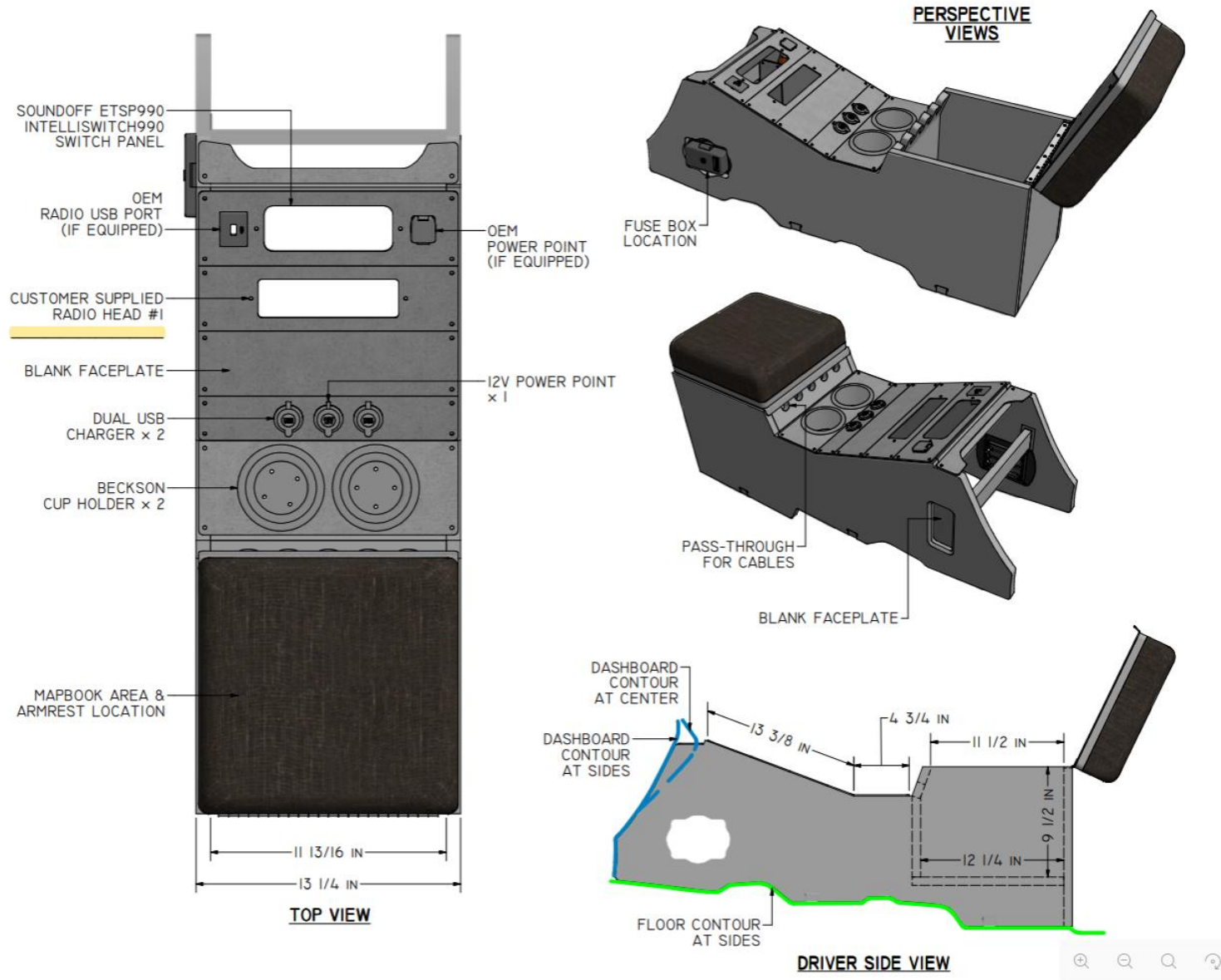

Examples of similar vehicles / equipment

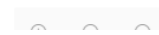
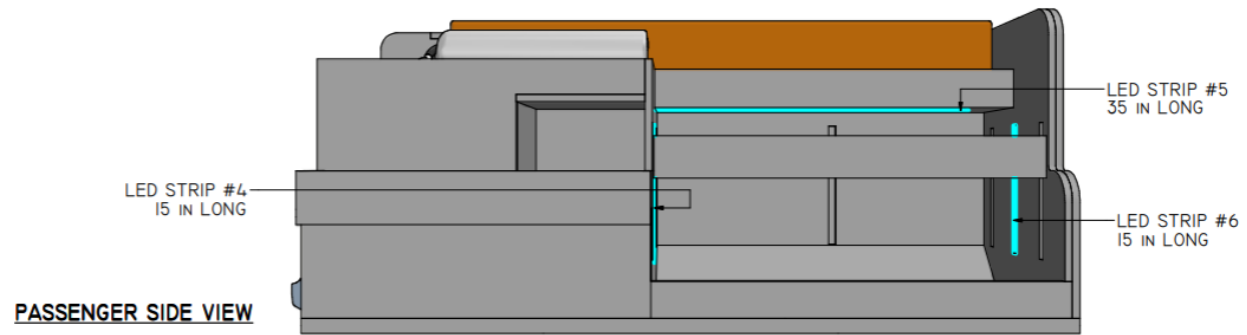
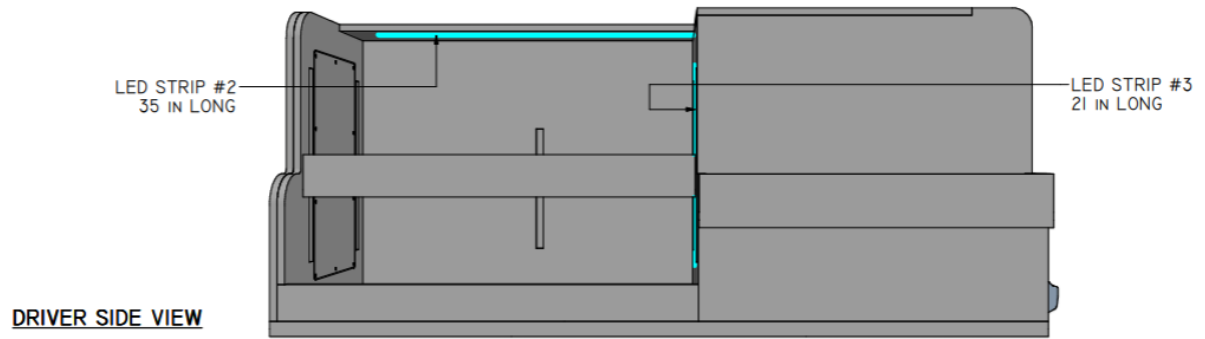
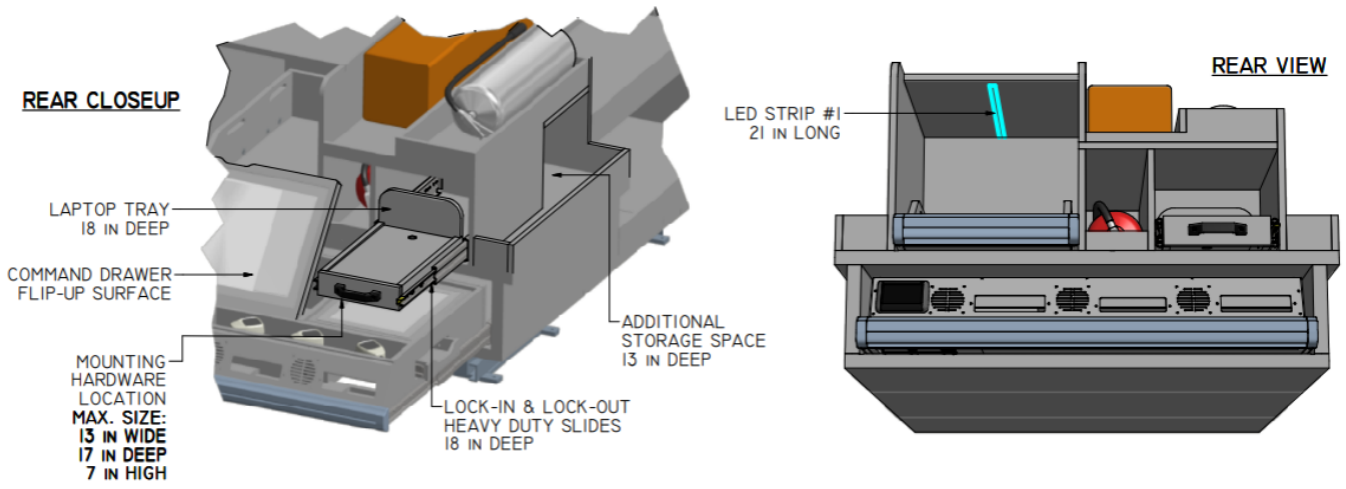

ATTACHMENT:

1. Fastlane Emergency Vehicles Quote
2. Vehicle Build Specification Book

RECOMMENDATION:

Staff are recommending the Public Safety Committee approve the purchase of the Command Vehicle from Fastlane Emergency Vehicles for \$141,116.

The purchase of customer supplied equipment is awaiting updated quotes, estimated at \$25,000 including 2026 price increases.

ACTION BY Committee:

FastLane Emergency Vehicles | 37241 E Richardson Lane | Purcellville, VA 20132 | (877) 327-8526



Fastlane Emergency Vehicles
Vehicle Build Specification

37241 E Richardson Lane | Purcellville, VA 20132 | (877) 327-8526

Job/Quote ID: Q00541.1

Client/Department Name: **Germantown Fire Department**

Rep: **Drew Crisp**

Conversion Up-fit of a(n) Ford F250

FastLane to supply vehicle? **YES**

FastLane Emergency Vehicles | 37241 E Richardson Lane | Purcellville, VA 20132 | (877) 327-8526

Chassis Specifications

If indicated above and vehicle is supplied by FastLane, the following specifications shall be considered "included in contract" Only specifications listed herein shall be considered inclusive. FastLane shall not be responsible for chassis specifications outside this document.

The vehicle, a(n) **Ford F250** shall be supplied by FastLane.

Please see the chassis specification document attached to the quote.

GENERAL BUILD SPECIFICATIONS

This section describes the minimum standards for how your new FastLane vehicle shall be converted/upfitted; specifically for the wiring, connections & terminations, mounting of equipment and power distribution.

WIRING

Wiring to be automotive type meeting or exceeding SAE J1128-GXL rated for minimum of +125 degrees centigrade. All wiring to be stamped with permanent, indelible marking describing both circuit identification and plain word function not less than 6 inches apart for the entire length of the wire. Each run to be rated for 125% the specified ampacity of the connected load. All wires to be run in split corrugated, nylon loom with minimum temperature rating of +115 degrees Centigrade. Loomed harnesses to be wire tied to frame and chassis not greater than 16 inches apart. All communication and data lines to be shielded and in independent harness from all other wires. All pass-through holes cut in body of vehicle where wire harnesses travel to have standard Heyco style bushings to protect from chaffing. All holes that pass to exterior of body to have approved, expanding sealing compound to seal wires from weather.

CONNECTIONS & TERMINATIONS

All connections made within the body, away from possible weather to be standard crimp style terminals with nylon insulation. Terminals must be crimped with approved tool specific to connector being used. All exterior or engine compartment connections (made on outside vehicle cabin) to be either heat shrink crimp style or Deutsch style, sealed connector and must protect against moisture, dirt and dust, minimum rating of -40 to 120 degrees Centigrade. All ground connections made on chassis frame or body on remote appliances to utilize star (toothed) ring terminal and be coated from weather and corrosion with silicon or approved sealant. Interface to OEM wiring shall be done in accordance with body builder and up-fitter specifications. Where possible any connection to OEM wiring shall use a tee style no-cut harness or shall be soldered into place using standard no-clean flux solder. This soldered connection shall then be covered in a dual wall, polyolefin, sealant lined heat-shrink tubing and heated into place with heat gun or portable torch. Under no circumstances shall fuse taps or crimp tee-taps be used to interface with OEM wiring.

MOUNTING OF EQUIPMENT

All FastLane added equipment to be mounted in accordance with manufacturers specifications. All interior cab items to be mounted with airbag safety standards followed. Modifications to the OEM frame assembly or suspension systems are prohibited. Any modification to bumper systems must be done such that not more than 10% of the entire surface area of the bumper assembly is breeched or modified. All cuts made to any chassis or body panel must be sealed with self-galvanizing, anti-rust sealer prior to equipment being mounted. All exterior hardware including screws and fasteners to be minimum of 18-8 stainless steel. All exterior lighting and thru-body equipment shall be fastened to the sheet metal of the vehicle using approved rivet nut fasteners, allowing the use of machine thread screws. The use of sheet metal screws directly into the body skin is prohibited.

POWER DISTRIBUTION (noise free power)

The main FastLane power feed is rated for 200% of total expected ampacity of the carried load. One large gauge cable run from vehicle's battery bank must be circuit protected within a minimum distance of 16 inches from power source (battery) and can be disconnected by user quickly in the event of emergency or maintenance. This protected power feed will power all FastLane added appliances and warning systems. Specified, lug style power studs will be in vehicle console and rear cabinet (if specified)

FastLane Emergency Vehicles | 37241 E Richardson Lane | Purcellville, VA 20132 | (877) 327-8526

to provided clean, capable power. Additionally main ground studs shall be placed in the front console and rear cabinet (if specified) for clean, noise free central grounding of all equipment. These ground cables shall be of matching size to main power feed and be bolted to frame rails using stainless steel fasteners and coated with approved sealing compound.

LIGHTBARS

As it is necessary to make an opening in the vehicle roof for lightbar cable(s) to be routed, proper and effective sealing of these hole(s) is of paramount importance. All wire holes through the vehicle roof will be protected with self-sealing, waterproof, hole-grommets when clearance is available (otherwise FastLane shall seal the hole using standard pliable "duct" seal agent).

FASTLANE SHALL SUPPLY/INSTALL THE FOLLOWING ITEMS:

The following lightbar shall be installed on the vehicle:

Manufacturer:

Model: **ENNLB011EE-26H**

Description: **54" nFORCE NXT Lightbar with LED Preemption, R/G/W Corners, R/W Front, Outermost Rear Module R/A**

Special Instructions:

TRAFFIC STICKS

The following rear traffic stick shall be installed on the roof of the vehicle:

Manufacturer:

Model: **EMPTC012H6**

Description: **mPower 8 Module Traffic System Tri-Color RAW**

Special Instructions:

BODY & WARNING LIGHTS

All exterior lighting shall be installed using approved rivnut fasteners and stainless-steel machine screws. Any holes or cuts in the vehicle's body shall be back primed with a self-etching primer to prevent corrosion. All connections between fixtures and cabling will be made with either heat shrink sealed or Delphi Deutsch style weatherproof connectors, wherever the likelihood of extensive exposure to the elements exists.

FASTLANE SHALL SUPPLY/INSTALL THE FOLLOWING ITEMS:

Item	Mounting Location	Quantity	Special Instructions
FPHLFlash: Fastplex Headlight Flashing Option	Headlights (both) - Within	1	Halo flash.
EMPS2001P-4: 4 Inch mpower Fascia with Stud Mount, Black Housing, RED/AMB/GRN (Specify Color and Function)	Liftgate, Rear - Interior Surface	2	
EMPS2STS4D: 4" mPower Stud Mount, Black Housing, RED/WHITE	Grill - Built-In	4	

FastLane Emergency Vehicles | 37241 E Richardson Lane | Purcellville, VA 20132 | (877) 327-8526

EMPS2QMS4D: 4" mPower Quick Mount Black Housing, 12 LED, Dual Color Red/White	Fenders (Both) - Front	2	
EMPS2QMS4D: 4" mPower Quick Mount Black Housing, 12 LED, Dual Color Red/White	*SEE NOTES THIS ITEM	4	Sides of Cap
fore and aft of door.			
EMPS2QMS4D: 4" mPower Quick Mount Black Housing, 12 LED, Dual Color Red/White	Body, Rear	2	Cap rear, vertical.
EMPS2QMS4D: 4" mPower Quick Mount Black Housing, 12 LED, Dual Color Red/White	Mirrors Side (Both) - Back	2	
FHLP-TAIL: Flasher, Taillight, Universal	Taillight's (Both) - Rear	1	
ESLRL6115D: SL Running Light, 61" - 5 Module, Dual Color Red/White	Running Boards, Kick Space Area	2	
PSLVBK05: Universal Mounting Kit for SL Running Light includes: Bracket & Hardware Kit	Running Boards, Kick Space Area	2	

SIRENS & AUDIBLE DEVICES

The following represents any audible warning devices being provided and/or installed as part of this upfit/conversion.

FASTLANE SHALL SUPPLY/INSTALL THE FOLLOWING ITEMS:

Primary Siren: **ENGSA5200CSR: bluePRINT® 500 Series Console Control System with Knob Control, 10-16v - 200 watt dual-tone.**

Speaker (**Qty: 2**): **C3100U, 100W Speaker with Universal Mount Bracket,**

Additional items for this section:

Item	Quantity	Special Instructions
CV2V: Vehicle To Vehicle Module, Includes Internal Antenna	1	
ETSKLF201: SoundOff LF Aftershock Siren System, includes: (2) 100 Watt Speakers, 200 Watt	1	

WORK LIGHTING

FastLane shall supply and/or install the following work lighting in your vehicle:

Install 2 red/white dome lights from **Techniq Lighting**, part **E13-LS0R-1: Silho-X 2.75 Round Neutral White/Red LED Map Light** in front headliner (or overhead console if so specified).

Additional items for this section:

FastLane Emergency Vehicles | 37241 E Richardson Lane | Purcellville, VA 20132 | (877) 327-8526

Item	Mounting Location	Quantity	Special Instructions
E45-OB03-1: Black Parallel Mount Screw Clip Qty 2	*STD	10	
E45-WBP10-1: 60 LED Premium 47.5" Aluminum Extrusion Lamp White	Liftgate, Rear - Interior Surface	1	
E45-WBP12-1: 72 LED Premium 56.5" Aluminum Extrusion Lamp White	*SEE NOTES THIS ITEM	3	
ARGFMKT: ARGES1 W/ ARGCH1 & ARGFM	Fender Driver's - Center Over Wheel	1	
ARG47DD: Ford F-250/F-350, 2023-2024, Ford F-450/F-550/F600 Super-Duty, 2023-2024, Driver Side Fender Mount		1	

FRONT CONSOLE

FastLane shall provide and install a custom **Full Floor Console** with the following details:

The custom front console to house all necessary switching, signaling and communications controls, as well as cup holders, map books and 12-volt power-points, as specified below. The primary console construction, if fabricated by FastLane (sides, front, rear), shall be of cabinet grade " lumber core or veneer core ply material, covered a durable polyurea coating, black. Where map book or other slots are provided, these spaces shall also feature the same coating. Whenever functions of the OEM installation are interrupted by the console such as rear radio, HVAC controls and ducting, these features shall be reintegrated into the new console (where possible). Installation of console includes mounting of all equipment listed herein for control and use by driver and passenger. FastLane reserves the right for production changes that require adjusting console appliance locations to fit according to size and use. Any mic clips will be shipped loose for installation at time of delivery. Consoles are fastened to vehicle chassis using threaded fasteners to floor. Dashboard support may be added for stability if needed. The face surface (top) of all front consoles shall be constructed of .090 aluminum sheet. These faceplates will be cut to size using CNC machining (not hand cut). All holes necessary in the faceplate (radios, switching, etc.) will be die-cut to a maximum allowable tolerance of +/- 0.05" through the aluminum. Gaps around mounted appliances will not be tolerated and shall be deemed unacceptable. The finished product will feature rounded edges and corners to prevent injury to people or equipment. These faceplates shall be finished with a black polyester powder-coat finish, producing a textured/wrinkle, scratch resistant coating.

Additional Standard Options

Install **1** standard **12V Power Points** in front console (see drawing for exact placement).

Install **2** marine style oversize **cup holders** in front console (see drawing for exact placement).

FastLane Emergency Vehicles | 37241 E Richardson Lane | Purcellville, VA 20132 | (877) 327-8526

Install 2 fully height adjustable, padded **arm rests** on front console.

Additional items for this section:

Item	Quantity	Special Instructions
OHCCWGLOVE: Overhead Control Console with Glove Storage Compartments	1	Glove storage + BluePrint controller.
USB/USBC-PP: 12V USB and USB Type C Faceplate Mounted Outlet	2	Switch to dual USB-C.

RADIOS

All listed radio equipment to be tested and operate within manufacturer's specifications prior to delivery of the vehicle described herein. The radios must be noise free (less than 10dB of spurious noise per unit) and be functional upon delivery (please note that it may not be possible to test all aspects of transmission and reception on Client's system. FastLane shall not be responsible for defects or damage to customer supplied radio equipment prior to possession by FastLane. All equipment shall be provided to FastLane, free from defects, programmed and in good working order. FastLane does not have the capability to program all makes and models of radios, therefore it shall not be the responsibility of FastLane to ensure proper function of the radio systems if any radios are supplied in an un-programmed state. Further, some systems require a home signal to function and therefore cannot be 100% tested at the FastLane facility.

Fastlane shall install 2 **customer supplied two-way radio(s)** in the **front console** area (final location to be determined by console design).

Special Instructions, Models or Details:

Note: Customer supplied radios must be provided prior to your scheduled start date. In addition, all radio equipment must be new or in working order when provided to FastLane for installation. FastLane is not responsible for any equipment that is damaged, not working or missing vital accessories to function.

Fastlane shall install 2 **customer supplied two-way radio(s)** in the **rear cabinet RCC area** (final location to be determined by console design).

Special Instructions, Models or Details:

Note: Customer supplied radios must be provided prior to your scheduled start date. In addition, all radio equipment must be new or in working order when provided to FastLane for installation. FastLane is not responsible for any equipment that is damaged, not working or missing vital accessories to function.

FastLane shall provide and install 2, **MB8U25 antenna coax run assemblies** that can operate from 0-1000 Mhz. Runs shall terminate to the vehicle roof using the standard Motorola NMO mount and include a rain cap upon delivery (if no antenna is provided by customer for installation).

FastLane Emergency Vehicles | 37241 E Richardson Lane | Purcellville, VA 20132 | (877) 327-8526

Special Instructions, Models or Details:

Fastlane shall install **4 customer supplied portable radio charger(s)**. The final location(s) to be determined by console design.

Special Instructions, Models or Details: **2x console, 2x rear.**

Note: Customer supplied radios must be provided prior to your scheduled start date. In addition, all radio equipment must be new or in working order when provided to FastLane for installation. FastLane is not responsible for any equipment that is damaged, not working or missing vital accessories to function.

Additional items for this section:

Item	Mounting Location	Quantity	Special Instructions
OHSPKRLG2: Overhead Speaker in Rear Liftgate (2-5W Speakers)	Cabinet, Rear RCC Area	1	
CSANT: Installation of Customer Supplied Antenna		2	Cradlepoint, WeBoost.
CSKNOX: Install Customer Supplied Knox Box Tied to Radio		1	In half toolbox.

COMPUTERS

FastLane shall incorporate the following mobile computers in the vehicle:

Additional items for this section:

Item	Quantity	Special Instructions
E131375: Elo 1594L 15.6-Inch Wide LCD - LED backlight	1	In command board.
F2RTSEXT-SET: Front to Rear Touchscreen Extension Cable Set (includes HDMI & USB for TS)	1	

REAR CABINET

A **CUSTOM** rear cabinet system, specifically built for the third (3rd) row of a(n) **F250** shall be provided and installed per the following specifications:

Installation of cabinet includes sizing and fitting to vehicle interior. FastLane shall utilize a minimum of four 3/8" diameter grade 5 carriage bolts to fasten the cabinet system to vehicle substructure or frame. Where possible cabinets shall be mounted through structural floor members such as frames or reinforcing plates; however, where mounting to body floor skin only FastLane shall utilize a minimum 4" diameter reinforced 3/16" thick steel plate for connection strength. All hardware utilized shall be

FastLane Emergency Vehicles | 37241 E Richardson Lane | Purcellville, VA 20132 | (877) 327-8526

rated at 150% of anticipated use and shall be coated to avoid rust and corrosion. All wood used in construction shall be lumber or veneer core ply. The cabinet shall be constructed using " LC/VC ply and be nailed, glued and screwed together at all fixed joints. All exposed edges shall be covered in a coordinating laminate or rubber edging. FastLane reserves the right for minor (cosmetic) modifications to the cabinet's design during final mounting.

Please refer to any FastLane supplied construction drawings for better illustration. However, the specifications within this document shall always supersede any illustrations, depictions or references made by any drawing, design or sketch. Equipment or installation of equipment not listed herein shall be considered for illustrative purposes only and not part of contract.

The cabinet shall include the following (add-on) options:

Item	Quantity	Special Instructions
SD24: Sundry Drawer, 24" Deep	1	
DEV: Dry Erase Vinyl (Per Square Foot)	10	Printed, to match South Oldham.
RCL: 12V Accessory Plug Adapter Socket	2	1x RCC, 1x midrow
RCCROLLOUT: Command Module Roll-Out to Include Rolling RCC	1	
CBLATSO: Lateral Slide Out Command Board Extensions (each)	2	
SM3-SP-74-41: Standard Slide 1000lbs Capacity, 100% Travel, 3 7/8" High, 74" Long x 41" Wide **painted silver**	1	
IDRS: Integrated Drawer Release System (front bar drawer release)	1	
USB/USBC-PP: 12V USB and USB Type C Faceplate Mounted Outlet	2	1x RCC, 1x midrow. Dual USB-C.
MIDROW60: Midrow Cabinet, Remove 60% Seat	1	Adjustable shelf and mapbook storage between the seats.
CMS: Wire Cable Management System (Cablechain-Igus) for roll out cabinet.	1	
LEDCOMPT-FM: LED Compartment Lighting, Flush Mounted (per compartment)	3	
NOTE: GENERAL NOTE	1	Match 90914 Osage Beach, but with ability to access gear storage from side.
110VGFI: 110V GFI 20A Receptacle	2	1x in cabinet, 1x in midrow.

EXTERIOR ACCESSORIES

All exterior accessories shall be matched to vehicle make and model and installed following manufacturer recommendations and instructions. By no means shall the original vehicle be modified (structurally) to install the equipment listed on this page.

FastLane shall provide/install the following exterior accessories:

FastLane Emergency Vehicles | 37241 E Richardson Lane | Purcellville, VA 20132 | (877) 327-8526

Item	Mounting Location	Quantity	Special Instructions
ARE100-HB: Full Rear Hatchback Door for ARE Commercial Cap (in lieu of hatch)		1	
ARE100-P2: Paint Match, P2 Series Color (Must Provide Color Code)		1	
ARE100-RC: Reverse Camera with Truck Harness for ARE DCU Cap		1	
AREDCU: DCU Series Commercial Truck Cap, Standard "Cab Height"		1	
CUSTCAPSHELF: Custom Fabricated Aluminum Shelf Between Bed Rail and Cabinet, entire length (Per Side)		2	

GRAPHICS

FastLane shall utilize only premium cast vinyl with a minimum life rating of 3 years outdoor durability on printed and gradient materials and a minimum of 5-years outdoor durability on all other lettering and striping materials. All efforts shall be made to avoid any bubbles or contaminants in the vinyl field, however small visual imperfections in vinyl are common. While a blemish free application is desired, any blemishes that cannot be seen with the naked eye by a reasonable witness from not less than three (3) feet shall be deemed acceptable and deliverable. To conform stiff materials such as reflective vinyl around complex curves, it may be necessary to perform "slack folds" inside door jambs and behind lighting fixtures, this practice shall be performed as little as possible, however some wrinkling in the vinyl may exist in these areas.

Lettering

FastLane shall produce and install the following lettering and markings on your vehicle:

Lettering	Location	Size [in]	Quantity	Material	Outline / Shadow	Special Instructions
GERMANTOWN FIRE DEPARTMENT	*SEE NOTES THIS ITEM	7	2	Graphics Material, Reflective Vinyl, Custom Printed Color	Printed Outline	Cap side doors.
XXXX	Fenders (Both) - Front	4	2	Graphics Material, Reflective Vinyl, Custom Printed Color	Printed Outline and Shadow	Unit designator, TBD.

Striping

FastLane shall produce and install the following striping and markings on your vehicle:

FastLane Emergency Vehicles | 37241 E Richardson Lane | Purcellville, VA 20132 | (877) 327-8526

Size [in]	Material	Add to Rear?	Special Instructions
5	Graphics Material, Reflective Vinyl, Premium	No	5" grey main stripe.
2	Graphics Material, FX Imitation Gold Vinyl	No	Dual 1" goldleaf pins.

Additional Emblems & Decals

FastLane shall produce and/or install the following decals/emblems on your vehicle:

Emblem	Size [in]	Quantity	Special Instructions
Custom Printed Decal/Seal, 8-12" (customer supplies artwork)	12	3	

Chevron

FastLane shall produce and install the following chevron marking on your vehicle:

Chevron Std Red/Lime NFPA, Perimeter Rear Hatch, Truck Cap or Body

ELECTRICAL ANALYSIS & UPGRADES

Analysis

The system has analyzed the added electrical loads based on the specifications herein, below are the results:

Vehicle OEM Alternator	410
Total Amperage Added	165.2
Reserve %	60

*Note: For any reserve percentage **below 25%** FastLane **HIGHLY** recommends to either reduce the overall added loads or upgrade the electrical generating capacity of the vehicle by either adding an alternator upgrade and/or high-idle system.*

Add Shoreline Inlet Power: **091-55-20-120: Super Auto Eject 20-AMP, 120V, Cover Color: Gray**

Add Vehicle Battery Charger: **PD9245C: 45-AMP CHARGER, WITH BUILT-IN CHARGE WIZARD**

Add Inverter for 110V Power: **PD1610: INVERTER 1000 Watt PD1600 SERIES INVERTER**

Additional Electrical Upgrade Items:

Item	Quantity	Special Instructions
FP3860: FastPlex 4.3-Inch, TouchScreen for Multiplex Control System	1	Second BluePrint controller in RCC Area.
FPLX-LVD: Fastplex Low Voltage Disconnect and Fuse Block for Non System Builds	1	

END OF BUILD SPECIFICATIONS

BUSINESS OF THE PUBLIC SAFETY COMMITTEE

MEETING DATE: January 5, 2026

PLACEMENT: Action Item

ITEM TITLE: ***A contract with Short Elliot Hendrickson (SEH) for design and construction inspection services related to the Fire Station #2 remodel and expansion. (ACTION)***

SUBMITTED BY: John Delain, Fire Chief

SUMMARY EXPLANATION:

A draft RFP for Fire Station #2 remodel and expansion design services was presented to the Village Board on October 27, 2025. At that meeting, the Village Board approved the draft and authorized staff to seek proposals.

As a refresher, the RFP was developed using multiple area Fire Department's recent RFP's, taking the best ideas from each and tailoring our draft to the needs of this project. The RFP identified a process, a staff evaluation committee, and a scoring rubric that would be used to evaluate firms.

The RFP was published by sending email notifications to firms, posting it on the Village website, posting it on Village and Fire Department social media, and posting it on the League of Wisconsin Municipalities website.

A summary of the evaluation process follows:

- Staff met with 11 prospective firms for a mandatory tour of Station 2 to discuss the project.
- 7 firms responded to the RFP. Each firm had varying levels of Fire Station experience, costs, and in some cases project scope.
- A staff committee of 6 members from the Fire Department, DPW, and Finance individually scored each response.
- The committee met to discuss scores of the responses.
- The top 2 scores were SEH and Wendel. They were brought in for an interview.
- Following the interview scoring, SEH had the highest score (85.83) but also had a higher cost.
- Staff met with SEH to review the project scope and negotiate a more favorable price. After the meeting, SEH reduced their proposed fee by \$51,000.
 - Reductions were related to the number of meetings, design timeline extension, bidding services being removed from their scope, utilization of junior consultants with review by senior consultants, and potential further reduction based on stormwater management requirements.

- Staff are recommending that the Village Board awards the contract to SEH for \$454,000.
 - \$436,500 Base Professional Services
 - \$17,500 Additional Services
 - Focus on Energy / Environmental Testing / Geotechnical

Documentation supporting all steps in the evaluation process is included in this write-up or attached to the packet. SEH will be present at the January 5th Village Board Meeting. They will be prepared to give a presentation or answer questions from the Village Board.

ATTACHMENT:

1. Design RFP Recommendation
2. Scoring Spreadsheet - Final - 010526
3. SEH's Technical Proposal for Professional Design Services for Village of Germantown Fire Station #2
4. Wendel's Proposal Response for Germantown WI Fire Station 2
5. Fire Station #2 - Cost and Rankings
6. Draft AIA Contract - Fire Station 2 Remodel and Expansion

STAFF RECOMMENDATION:

Staff recommend the Village Board award the design services contract for the remodel and expansion of Fire Station 2 to Short Elliott Hendrickson, Inc. (SEH) for the amount of \$454,000 and authorize staff an additional 10% contingency of \$45,400, bringing the total authorized amount to \$499,400.

ACTION BY COMMITTEE:

Fire Station 2 Remodel & Expansion: Design Phase



Goal

Enhance community safety through the renovation and expansion of the existing fire station, ensuring continuity of emergency operations, protection of responder health and safety, adaptability for future needs, and responsible stewardship of public funds.

Project Priorities

**Firefighter
Health and
Safety**

**Fiscal
Responsibility**

**Meets 5-Year
Needs**

**Limit
Operational
Impact**

**Future Proof
Design**



Project Development

- Village Board directed staff to pursue a remodel and expansion of Station 2
- Meet 5-year needs with future needs addressed by headquarters station
- Staff presented several programmed designs and preliminary cost estimates
- Several opportunities to be addressed during design phase



Preliminary Cost

- \$500,000 budgeted for design and architecture services
- Preliminary construction cost estimate - **\$6.50M-6.60M**
- Project cost increases ~3-5% per year

Detail	Cost
Direct Construction Cost	\$4,494,931
Professional Services	\$989,208
Owner Items	\$651,567
Contingency	\$449,493
Total Project Cost	\$6,585,199

Estimate from Moore Construction, August 2025

Timeline



Ongoing

Present updated budget(s) and design(s)



January 2026

Staff present RFP recommendations and Village Board awards design contract



January 2026

Begin design phases



Quarter 1 2027

Construction bidding



Quarter 2 2027

Expansion groundbreaking



2028

Completion / Occupancy



2031

Begin process for Headquarters Station

Schedule subject to change

Design Phases

Phase 1: Data Collection

Review space needs

Compile room data sheets

Receive stakeholder input

Develop and present space program(s)

Update cost estimates

Phase 2: Detailed Design

Develop detailed plans

Present updated and refined cost estimates

Determine construction phasing

Phase 3: Construction Administration

Perform site visits

Verify build quality

Manage change orders

Conduct completion inspection

Create punch list

Perform warranty reviews

RFP Process

- 11 companies attended informational session
- 7 companies submitted proposals
- Staff reviewed proposals, contacted references, and assigned points
- In-person interviews with SEH and Wendel

Company	Points Awarded
SEH	85.83
Wendel / 5 Bugles	83.50
Bray	65.83
Angus-Young	64.67
Kueny	64.00
PRA/GRAEF	61.67
FGMA	60.50

RFP is available for viewing on Village's website

Fee Negotiation

- SEH received the highest score of 85.83
- Staff negotiated a more favorable price
- Negotiated Services:
 - Reduce the number of meetings
 - Extend the design timeline
 - Reduce the review of prior space programming
 - Bidding services by Construction Manager
 - Senior staff review/oversight of Junior staff

Service	Initial Cost	Negotiated Cost	Reduction
Professional Services	\$487,500	\$436,500	\$51,000
Additional Services	\$17,500	\$17,500	\$0
Total	\$505,000	\$454,000	\$51,000

*SEH Fee
Breakdown*

SEH Fee Breakdown

Professional Service	Initial Proposed Service Fee	Negotiated Service Fee	Fee Reduction
Architectural	\$255,000	\$223,000	\$32,000
Structural	\$65,000	\$65,000	\$0
Civil	\$49,000	\$44,000	\$5,000
MEP and FP	\$96,000	\$90,000	\$6,000
Landscape	\$8,000	\$0	\$8,000
Interior Design	\$4,500	\$4,500	\$0
Envelope Consultant	\$5,000	\$5,000	\$0
Expenses	\$5,000	\$5,000	\$0
Subtotal of Professional Services	\$487,500	\$436,500	\$51,000
Additional Services	Initial	Negotiated	Reduction
Focus on Energy	\$2,500	\$2,500	\$0
Environmental Testing	\$7,500	\$7,500	\$0
Geotechnical Engineering	\$7,500	\$7,500	\$0
Subtotal of Additional Services	\$17,500	\$17,500	\$0
Total of Services	\$505,000	\$454,000	\$51,000

Recommendation



STAFF RECOMMENDS THE VILLAGE BOARD AWARDS THE PROFESSIONAL SERVICES CONTRACT FOR STATION 2 IN THE AMOUNT OF \$454,000 TO SEH

- SEH has extensive fire station design experience – locally and nationally
- Highest scoring proposal: 85.83/100
- References gave positive recommendations of their work
- Proposal was the most tailored to the project at hand

	RFP Requirements (15)	References (10)	Cost (35)	Consultant Team Qualifications (20)	Interview (20)	Total
FGMA						
Evaluator 1	9	8	29	17		63
Evaluator 2	10	8	25	17		60
Evaluator 3	11	7	29	17		64
Evaluator 4	8	8	23	15		54
Evaluator 5	9	8	24	17		58
Evaluator 6	10	9	27	18		64
FGMA Score						60.5

	RFP Requirements (15)	References (10)	Cost (35)	Consultant Team Qualifications (20)	Interview (20)	Total
SEH						
Evaluator 1	13	8	30	18	19	88
Evaluator 2	13	9	27	19	19	87
Evaluator 3	13	9	30	18	17	87
Evaluator 4	12	8	25	16	18	79
Evaluator 5	13	9	28	18	19	87
Evaluator 6	14	10	29	17	17	87
SEH Score						85.83333

Scores

FGMA	60.5
SEH	85.83333
A-Y	64.66667
Wendel	83.5
Kueny	64.00
Bray	65.83333
PRA	61.66667

Cost				
Firm	LS	Percent	Equiv	Rank
PRA	\$424,900		\$424,900	4
Bray		6.50%	\$396,500	3
KUENY*	\$166,250		\$166,250	1
Wendel		7.90%	\$481,900	5
A-Y	\$334,250		\$334,250	2
SEH	\$487,000		\$487,000	6
FGMA	\$490,000		\$490,000	7

*If \$6.1M in construction cost fee equals \$289,750

	RFP Requirements (15)	References (10)	Cost (35)	Consultant Team Qualifications (20)	Interview (20)	Total
Angus-Young						
Evaluator 1	12	7	34	15		68
Evaluator 2	11	5	33	15		64
Evaluator 3	11	5	34	10		60
Evaluator 4	12	8	33	15		68
Evaluator 5	11	7	34	13		65
Evaluator 6	9	7	33	14		63
					A-Y Score	64.66667

	RFP Requirements (15)	References (10)	Cost (35)	Consultant Team Qualifications (20)	Interview (20)	Total
Wendel						
Evaluator 1	13	9	31	17	15	85
Evaluator 2	12	9	25	15	17	78
Evaluator 3	14	10	31	19	17	91
Evaluator 4	12	8	27	12	16	75
Evaluator 5	13	9	28	17	17	84
Evaluator 6	14	9	28	19	18	88
					Wendel Score	83.5

	RFP Requirements (15)	References (10)	Cost (35)	Consultant Team Qualifications (20)	Interview (20)	Total
Kueny						
Evaluator 1	11	6	34	15		66
Evaluator 2	10	6	34	15		65
Evaluator 3	9	4	34	10		57
Evaluator 4	11	8	34	15		68
Evaluator 5	10	7	34	12		63
Evaluator 6	9	8	34	14		65
				Kueny Score		64

	RFP Requirements (15)	References (10)	Cost (35)	Consultant Team Qualifications (20)	Interview (20)	Total
Bray						
Evaluator 1	8	9	33	16		66
Evaluator 2	9	8	31	16		64
Evaluator 3	11	8	33	17		69
Evaluator 4	8	8	31	18		65
Evaluator 5	9	8	31	17		65
Evaluator 6	11	7	33	15		66
					Bray Score	65.83333

	RFP Requirements (15)	References (10)	Cost (35)	Consultant Team Qualifications (20)	Interview (20)	Total
PRA						
Evaluator 1	11	5	35	15		66
Evaluator 2	10	5	27	12		54
Evaluator 3	10	5	32	12		59
Evaluator 4	12	8	29	16		65
Evaluator 5	11	5	30	15		61
Evaluator 6	12	7	31	15		65
					PRA Score	61.66667

RFP FOR PROFESSIONAL DESIGN SERVICES FOR

Remodel and Expansion of Fire Station #2

VILLAGE OF GERMANTOWN, WISCONSIN | NOVEMBER 24, 2025

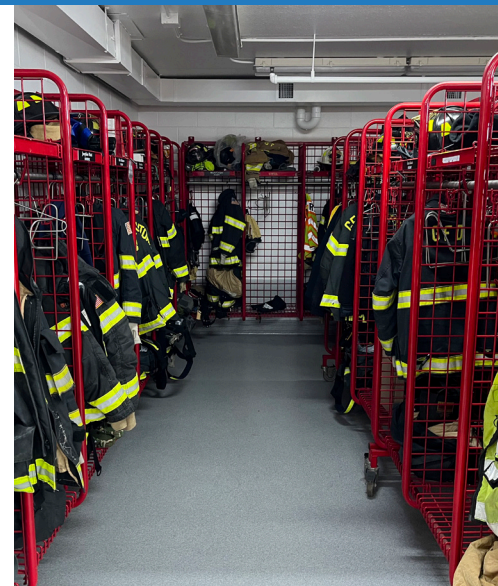

Building a Better World
for All of Us®

Engineers | Architects | Planners | Scientists

November 24, 2025

Germantown Fire Station 2
N115W18752 Edison Drive
Germantown, WI 53022



Building a Better World
for All of Us®

RE: RFP for Professional Design Services for Village of Germantown Fire Station #2

Dear Members of the Selection Committee,

The Village of Germantown is taking meaningful steps to strengthen its emergency response capabilities and improve the working environment for its fire personnel. With plans to remodel and expand Fire Station #2, the Village is seeking a consultant partner that understands the unique demands of fire station design and can deliver a solution that meets current and future needs.

Short Elliott Hendrickson Inc. (SEH®) is ready to support the Village in this effort. We will work closely with your team to design a facility that enhances daily operations, supports long-term growth, and reflects Germantown’s commitment to public safety. In this capacity, SEH is prepared to offer the following advantages:

SPECIALIZING IN FIRE STATION DESIGN

SEH has designed fire station projects across Wisconsin and the country that mirror Germantown’s needs, scope, and budget. We understand the importance of aligning design with operational needs and future-proofing facilities for evolving technologies and staffing models. We’ll collaborate with your staff to create a facility that supports training, response, and rest, while staying on budget and schedule.

DESIGNING FOR THE WELLBEING OF YOUR STAFF AND DEPARTMENT

SEH’s approach to fire station design reflects the evolving needs of today’s departments. We incorporate features that promote firefighter wellness, reduce cancer risk, and support mental health, such as zoned layouts, dedicated decontamination areas, and quiet recovery spaces. We also design with recruitment and retention in mind, creating environments that foster pride, comfort, and long-term usability. These priorities will guide our work on Fire Station #2 and help Germantown attract and retain top talent.

MAINTAINING YOUR OPERATIONS THROUGHOUT THE PROCESS

SEH has delivered fire station projects that remained fully functional throughout construction. We will develop a phasing plan that allows Germantown Fire Station #2 to maintain 24/7 service while addressing key facility upgrades, including sleeping quarters, training space, and HVAC improvements. Our approach will prioritize safety, minimize disruption, and align with the Village’s staffing and apparatus needs.

We appreciate the opportunity to be considered for this important project and look forward to the possibility of working with the Village of Germantown.

Respectfully submitted,



MARK ZVITKOVITS

MARK “MARTY” ZVITKOVITS
AIA, LEED GA, ARCHITECT IN WI
PROJECT MANAGER



TREVOR FRANK

TREVOR FRANK AIA, LEED
AP®, NCARB, PMP, ARCHITECT IN WI
PRINCIPAL IN CHARGE

“Let’s get to work to deliver a fire station that meets today’s needs and anticipates tomorrow’s challenges with confidence.”

Engineers | Architects | Planners | Scientists

Short Elliott Hendrickson Inc., 316 North Milwaukee Street, Suite 302, Landmark Building, Milwaukee, WI 53202-5888
414.465.1200 | 888.908.8166 fax | sehinc.com

SEH is 100% employee-owned | Affirmative Action–Equal Opportunity Employer



CONTENTS

FIRM'S INFORMATION	1
KEY INDIVIDUALS QUALIFICATIONS AND EXPERIENCE	8
KEY SUBCONSULTANTS, EXPERIENCE, RESPONSIBILITIES	15
PROPOSED SERVICES	21

The specific licenses and credentials of the team members are described in the personnel and/or resume section of this document.

©2025 Short Elliott Hendrickson Inc.

The information contained in this Proposal was prepared specifically for you and contains proprietary information. We would appreciate your discretion in its reproduction and distribution. This information has been tailored to your specific project based on our understanding of your needs. Its aim is to demonstrate our ideas and approach to your project compared to our competition. We respectfully request that distribution be limited to individuals involved in your selection process.

SEH is a registered trademark of Short Elliott Hendrickson Inc.

GERMV 187465

Firm's Information





Firm's Information

The SEH team is excited for the opportunity to work with the Village of Germantown on this effort. Our local team allows us to constantly communicate among each other to keep your project on schedule and within budget all while working as your partner to help you achieve your goals. Let's get started!.

At SEH, our 900+ dedicated employee-owners are united by a shared vision to create positive, lasting change. **We are deeply committed to fostering an equitable environment and building safer, more sustainable infrastructure for governments, industries, and businesses across the nation.** By embracing technology and delivering climate-sensitive design solutions, we strive to improve lives, enhance communities, and establish a legacy of positive change.

ARCHITECTURAL DESIGN

SEH sees architectural design as an opportunity to improve the way we interact with one another and our environment.

We see an opportunity to unite form and function, style and durability, and beauty and purpose in ways that support our clients' needs. Although experienced in a diverse mix of projects, our architects are especially experienced in municipal and civic work with public safety facilities, including fire station design as a main focus. Our integrated project teams understand how to make the most of your investment and design functional and sustainable facilities that work for those who own, use, and maintain them.

INTENTIONAL FIRE STATION PLANNING AND DESIGN



10 Trends Transforming Fire Station Planning & Design



SCAN this

QR Code

for our new eBook!

Putting out fires is just 3% of a firefighter's role. Today, they're relied on for emergency medical services, public safety and protection, community education, and so much more. Unfortunately, the continuously increasing demand is taking a toll on our nation's 1.1 million firefighting professionals. In response, future-forward leaders like SEH are seeking not to accommodate but rather empower their workforces through intentional planning and design, culture building, and training/education.

OFFICE LOCATION

316 North Milwaukee Street, Suite 302
Landmark Building
Milwaukee, WI
53202-5888

OWNERSHIP/ AFFILIATION

100% Employee-Owned
C Corporation

NUMBER OF EMPLOYEES

900+

SHORT ELLIOTT HENDRICKSON INC.

founded in

1927

WE PARTNER WITH CLIENTS



in nearly every
U.S. state and many
Canadian provinces

EMPLOYING

900+

engineers, architects,
planners, scientists, and
talented professionals

WHO WORK TOGETHER TO SERVE

4 market areas: mobility,
better places, clean water,
and renewing infrastructure



AN IMPRESSIVE 80%



of our clients are
repeat customers

PAST PERFORMANCE

Our team has delivered public safety projects throughout the United States. Our team has collaborated on many of these projects, and our complementary skill sets yield positive results for the departments and stakeholders we served. For detailed insights, please refer to the contact references provided on each respective project page.

COMPLETED IN LAST FIVE YEARS

- Buffalo Fire Station – Buffalo, MN
- Durango Fire Station #3 – Durango, CO
- Fire Station – Fenton, IA
- North East Station – Fitchburg, WI
- Fire Station #2 – Greeley, CO
- Fire Station #6 – Greeley, CO
- Fire Station #5 Addition – Ignacio, CO
- Bain School Site Fire Station – Kenosha, WI
- Fire Station #2 Schematics – Sheboygan, WI
- Fire Station #4 Improvements – Kenosha, WI
- Fire Station #7 – Kenosha, WI
- Fire Station #4 Design – Kenosha, WI
- Fire Stations 2-6 Study – Lynchburg, VA
- Fire Stations 1, 7, and 8 – Lynchburg, VA
- North Fire Station – Maplewood, MN
- Fire Station – Pewaukee, WI
- Fire Station #31 – Omaha, NE
- Fire Station #6 – Saint Cloud, MN

- Fire Station #1 Remodel – Telluride, CO
- Fire Station #5 Design – Telluride, CO
- Placerville Fire Station – Telluride, CO

IN PROGRESS

- Fire Station Design Services – Avoca, IA
- Fire Station #28 Repair – Denver, CO
- Durango Fire Station #2 – Durango, CO
- Fire Station Phase II – Frisco, CO
- Keystone Fire Station #11 – Frisco, CO
- Fire Station – Griswold, IA
- New Fire Station – Little Chute, WI
- Fire Stations #2 and #6 – Longmont, CO
- Fire Station #9 – Lynchburg, VA
- Station #5 Renovation – Lynchburg, VA
- Fire Station Renovation – Neenah/ Menasha, WI

- Fire Station #53 – Omaha, NE
- Central Fire Training Facility – Oshkosh, WI
- Police/Fire Station – Prairie du Chien, WI
- Police and Fire Station – Rocky Ford, CO
- Springville Fire Station – Tazewell, VA
- Fire Station – Watertown, WI
- West Bend Fire Station – West Bend, WI
- Fire Training Facility Master Plan – Marshfield, WI
- Fire Station Expansion and Remodel – Town of Paris, WI
- Public Safety Facility (Police and Fire Station Design) – Plover, WI
- Fire Station Design – South Walton Beach, FL
- Fire Station #10 – St. Joseph, MO
- Public Safety Facility – Biwabik, MN
- Fire Station Concept Design – Cumberland, WI
- Fire Station – Walton County, FL

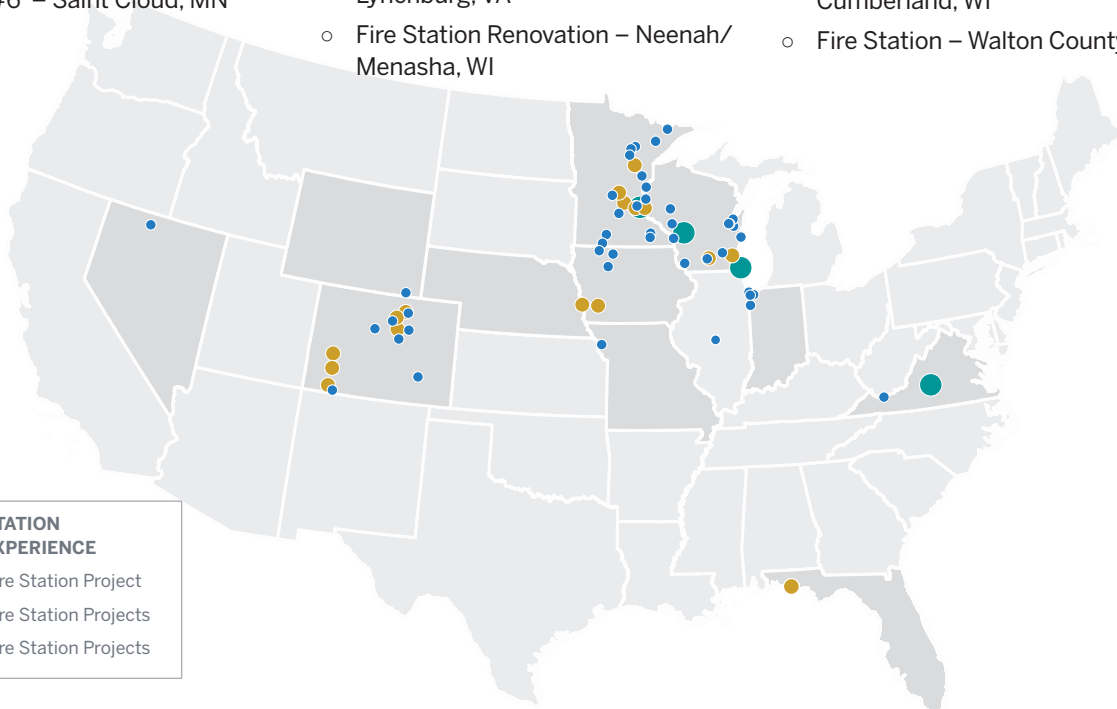

FIRE STATION 31 RENOVATION

NEENAH, WI



The remodel of Fire Station 31 is a significant undertaking aimed at expanding the department's capacity and operations. The project focuses on enhancing the functionality, safety, and efficiency of the facility, which serves as a training center, Emergency Operations Center, and living quarters for full-time firefighters. Key objectives include optimizing workflow, prioritizing health and safety with cancer prevention measures, and creating separate defined spaces for Neenah-Menasha Fire Rescue, the clinic, and technology servers. The remodel will address issues such as inappropriate room sizes, outdated interior finishings, and inadequate facilities for multiple genders.

SEH is also working with the City to future-proof the facility to accommodate a diverse workforce, including gender-neutral restroom and sleeping quarter designs. Additionally, the remodel will improve efficiency and storage capacity, re-envisioning the overall program to provide more space for gear and better separation of department spaces from other facility functions.

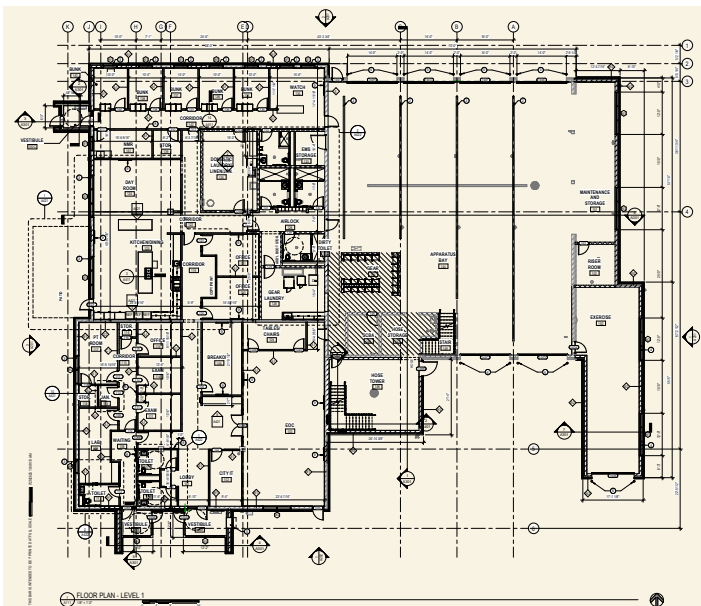

CLIENT

City of Neenah



COST

Design Fee

Architect's Estimate: \$465,580

Actual: \$465,580

Construction Costs

Architect's Estimate: \$6,200,000

Actual: \$5,899,928



YEARS

Design: 2025

Construction: Currently under construction (Completion Sept. 2026)



REFERENCE

Travis Teesch, Fire Chief

920.470.5689

fire@nmfire.org



KEY PERSONNEL

Trevor Frank, Project Manager

Mark Zvitkovits Project Architect

Charles Leipzig, Department Operations Manager



NEW FIRE STATION



RENOVATION

FIRE STATIONS NO. 4 AND NO. 7

KENOSHA, WI



FIRE STATION NO. 4

The new 29,260 sq. ft. fire and EMS station was built on the site directly adjacent to the operating station house that's being replaced. Once the new facility came on line, the existing 1964 structure was removed. The new facility acts as the department headquarters and fire training center with both academic classroom space and a training tower. The building features gender neutral accommodations for both men and women firefighters, as well as several sustainable features to reduce energy consumption and environmental impact.

The station is also home to the fleet maintenance mechanic and shop spaces. Two bays of the station are dedicated to service and maintenance of fire apparatus and equipment.

FIRE STATION NO. 7

SEH provided architectural and engineering support to investigate, develop a mitigation plan, and create architectural details that solved the station's moisture infiltration issues. Our team provided forensic testing to the exterior wall assembly to determine the cause of moisture infiltration and mold that was forming on the interior wall surfaces of the living areas in the station. Once the cause of the infiltration was identified, the team created architectural details to prevent future moisture mitigation. At the same time, SEH's structural engineers investigated the deteriorating condition of the steel catwalks and training platforms within the training and hose tower and developed recommendations for the shoring up and replacement of the failing structural members.

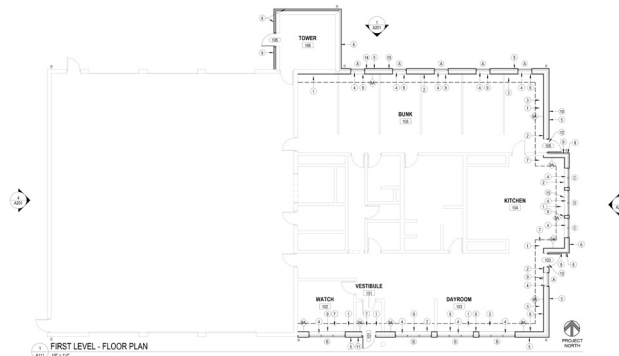

CLIENT

City of Kenosha



COST

No. 4

Design Fee

Architect's Estimate: \$412,533

Actual: \$428,283

Construction Costs

Architect's Estimate: \$9.5 million

Actual: \$9.26 million

No. 7

Design Fee

Architect's Estimate: \$85,585

Actual: \$85,585

Construction Costs

Architect's Estimate: \$615,540

Actual: \$625,800



YEARS

No. 4

Design: 2021

Construction: 2022

No. 7

Design: 2022

Construction: 2024



REFERENCE

Daniel Tilton, Fire Chief

262.653.4100

dtilton@kenosha.org



KEY PERSONNEL

Trevor Frank, Project Manager/Senior Project Architect

Mark Zvitkovits, Project Design Leader

Chuck Leipzig, Department Operations Manager

FIRE STATIONS NO. 1, 5, 7, AND 8

LYNCHBURG, VA

Station 1 – Existing

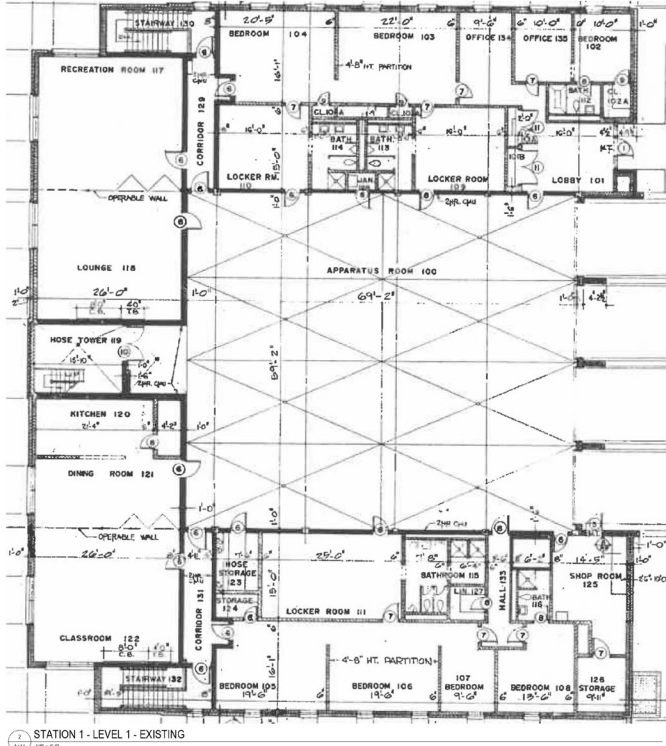

Station 1 – Option 1



SEH is helping the department prioritize design improvements for their aging fire station facilities. Key challenges include cancer prevention and mitigation through environmental design; gender neutrality and “future proofing” stations for long-term staffing, including providing more amenities like nursing mothers rooms, unisex locker rooms, and wellness rooms; and improving station image and pride of place, which supports recruitment and retention for the department.

SEH is providing test fit documents showing separation and orientation for cancer prevention measures, floor plan efficiency, and interior traffic patterns, as well as any interior renovation or additions. A listening session with the female firefighting staff of the department will inform the improvements. SEH is promoting operational efficiency within the stations by mapping internal response times within the station. This provides understanding of how physical arrangement of space impacts the time it takes for firefighters to get to the truck floor from various parts of the station. A matrix of need will explain the condition of each station, ranking them in terms of need and priority.



CLIENT

City of Lynchburg



COST

Station 1 Estimated: \$3,976,500
 Station 5 Estimated: \$525,590
 Station 7 Estimated: \$2,295,000
 Station 8 Estimated: \$1,670,969



YEARS

Station 1: CIP planning for funding in 2026
 Station 5: November 2024 (in construction)
 Station 7: CIP planning for funding in 2027
 Station 8: CIP planning for funding in 2028



REFERENCE

Deputy Chief Jonathan Wright
 434.455.6353
 jonathan.wright@lynchburgva.gov



KEY PERSONNEL

Trevor Frank, Principal in Charge/
 Project Manager
 Mark Zvitkovits, Project Architect

FIRE STATION NO. 15

OSHKOSH, WI



The City of Oshkosh faces the same challenges many fire departments do across the United States. As the delivery of fire services to communities changes, fire departments need to adapt not only to the latest best practices but also accommodate the gender mix in firefighters entering the fire service.

The Oshkosh Fire Department (OFD) is fortunate in that they have a healthy and diverse mix of male and female firefighters. The challenge is accommodating the needs of female firefighters, as separate sleeping and showering facilities are not available in the existing Fire Station 15.

Renovations to the living quarters in the headquarters station are necessary to accommodate the influx of female firefighters. The plan calls for a complete remodel of the second floor living areas in Station 15. This includes developing private sleeping rooms, unisex showering and changing facilities, and a nursing mother's suite.

The OFD fire chief assigned specific inter-departmental staff to the project to gain insight from several diverse backgrounds. Training chiefs, operations staff, physical fitness champions, maintenance personnel, and project managers all worked closely with the SEH design team to build consensus and have a voice in the programming and design of their best-in-class training facility.



CLIENT

City of Oshkosh



COST

Estimated: \$1,848,478
Actual: TBD



YEARS

The project is in schematic design and budgeting and will be a line item in the city's CIP in 2026.



REFERENCE

Tim Heiman, Fire Chief
262.424.1326
theiman@oshkoshwi.gov



KEY PERSONNEL

Trevor Frank, Project Manager/Senior Project Architect
Mark Zvitkovits, Senior Project Architect
Chuck Leipzig, Programming Specialist
Molly Wagner, Landscape Architect



LOWER LEVEL FLOOR PLAN

GROUND LEVEL FLOOR PLAN

NEW FIRE STATION NO. 1 DESIGN

WEST BEND, WI



SEH and our design team partners have been working with the City of West Bend to develop a central headquarters fire station and fire operations training facility within their community. The roughly 40,000 sq. ft. station incorporates best practices for firefighter health and safety, as well as tactical and classroom training functions that will allow the firefighters to train in quarters and on the adjacent fire station site property.

Best practices for firefighter health and safety include separate gross decontamination areas located in the red or hot zone areas of the station that accommodate the decontamination of gear and equipment. Adjacent to these hot zone decontamination areas are personnel decontamination spaces where firefighters remove carcinogens and other harmful hazards from their bodies prior to entering the green zone or cold zone of the fire station or daily work and living activities take place.

The station features training props located off the apparatus bay floor, allowing in-house evolutions and tactical practice to be conducted while in quarters, eliminating the need for off-site training and reducing the risk of delayed emergency response.

The site's remote training areas support live burn exercises, extrication scenarios, simulated mass casualty events, and hazardous environmental spill response training.

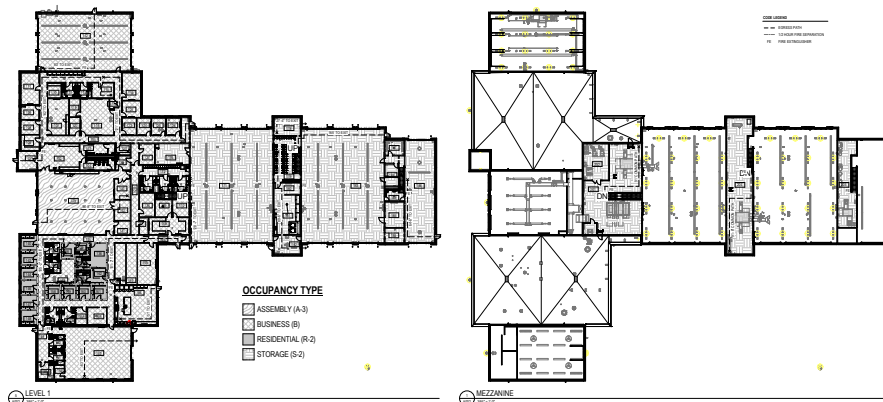

CLIENT

City of West Bend



COST

Design Fee

Architect's Estimate: \$793,378
Actual: \$801,878

Construction Costs

Architect's Estimate: \$24,000,000
Actual: \$23,898,122



YEARS

Design: 2025
Construction: Currently under construction



REFERENCE

Joel Ongert, Mayor
262.335.5111
mayor@westbendwi.gov

Cory Henschel
CD Smith (Construction Manager)
920.904.1890
chenschel@cdsmith.com

Les Norin, Fire Chief
262.335.5054 (office)
norinl@westbendwi.gov



KEY PERSONNEL

Mark Zvitkovits, Project Manager/
Project Architect
Molly Wagner, Landscape Architect
Trevor Frank, Senior Project Architect

Key Individuals Qualifications and Experience





Key Individuals Qualifications and Experience

Our team, listed below, has a deep understanding of the community’s needs, Germantown’s goals for this facility, and how to plan and design top-quality fire stations. This team’s strengths will facilitate an efficient, budget-conscious approach, leading to the delivery of a successful project.

Village of Germantown

John Delain, Fire Chief, Project Director

KEY INDIVIDUALS

Mark “Marty” Zvitkovits

AIA, LEED GREEN ASSOCIATE
Project Manager, SEH

Trevor Frank

AIA, LEED AP®,
NCARB, PMP
Principal in Charge, SEH

Chuck Leipzig

Operations Specialist, SEH

Brian Depies

Client Service Manager, SEH

ARCHITECTURE AND LANDSCAPE ARCHITECTURE

Schawn Jubert

WRID L LEED
AP ID&C
Senior Interior Designer,
Atmosphere

Taylor Douglas

Architectural Designer and 3D
Visualizations Specialist, SEH

Molly Wagner

PLA
Landscape Architect, SEH

STRUCTURAL AND CIVIL ENGINEERING

Matt Gundry

PE
Structural Engineer, SEH

Brad Hartjes

PE
Senior Civil Engineer, raSmith

Troy Hartjes

PE
Civil Engineer, raSmith

Joshua Fleming

PE
Civil Engineer, raSmith

MECHANICAL AND ELECTRICAL ENGINEERING

Macen Leonardi

PE, LEED
BC+C
Plumbing Engineer, MSA

Laura Gilbert

PE
Senior Electrical Engineer,
MSA

Jason Testin

DES
Senior HVAC Engineer, MSA

ENVELOPE CONSULTANT

Bruce Flater

RRO
Forensic Engineer, STR-SEG

Russell Mohns

PE
Forensic Engineer, STR-SEG

The specific licenses and credentials of the team members are described in the following pages.

MARK “MARTY” ZVITKOVITS AIA,

LEED GREEN ASSOCIATE

PROJECT MANAGER | SEH



Mark will serve as overall project manager and be your primary point of contact. He will oversee the team and monitor the schedule and budget.

Mark is an architect with experience in architectural design and construction documents. He works with AutoCAD Architecture and Autodesk Revit Architecture on a variety of building project types varying in square footage and cost. Mark’s responsibilities range from drafting schematic drawings through construction drawings and construction administration. He works on design calculations and layout, as-built drawings, cost estimating, and shop drawing reviews.

EXPERIENCE

- Fire Station 31 (Neenah-Menasha Fire Rescue) – Neenah, WI
- Kenosha Fire Stations No. 1, 2, 4, 6, and 7 – Kenosha, WI
- Fire Stations 1, 7, and 8 – Lynchburg, VA
- Odd Fellows Road Fire Station #9 (Liberty University Campus) – Lynchburg, VA
- New Fire Station – West Bend, WI
- Sheboygan Station #3 Headquarters Master Planning – Sheboygan, WI
- Fire Station #2 Schematic Design – Sheboygan, WI
- Public Safety Building – Prairie du Chien, WI
- Police, EMS, and Fire Department Space Needs Analysis – Prairie du Chien, WI
- Fire/Police Station Needs Assessment and Site Analysis Study – Rice Lake, WI
- Police and Fire Department Master Planning – Brillion, WI
- Town Hall, Fire, and Police Station – Freedom, WI
- Fire Station Design – Kaukauna, WI
- North East Fire Station Design – Fitchburg, WI
- North West Fire Station Design – Fitchburg, WI
- Black River Falls Emergency Services Building – Black River Falls, WI
- Watertown Fire Station – Watertown, WI
- New Fire Station #6 – St. Cloud, MN
- Fire Department Station #4 Replacement and Memorial Park Trail Head Facility – Appleton, WI
- Fire Station 2 Remodel – De Pere, WI
- Oshkosh Fire Department Operations Analysis and Long-Term Needs Assessment – Oshkosh, WI
- Maplewood North Fire Station – Maplewood, MN
- New Fire Station Schematic Design – Greenville, WI



17

YEARS OF EXPERIENCE



EDUCATION

Bachelor of Science Architecture
University of Wisconsin-Milwaukee



REGISTRATIONS/CERTIFICATIONS

Architect in WI
Firefighter I/HazMat Ops, Lakeshore Technical College
LEED Green Associate, U.S. Green Building Council
Driver/Operator – Pumper, Milwaukee Area Technical College
Driver/Operator – Aerial, Moraine Park Technical College



PROFESSIONAL ASSOCIATIONS

American Institute of Architects
U.S. Green Building Council
International Association of Firefighters



CONTACT INFORMATION

mzvitkovits@sehinc.com
920.380.2847



OFFICE LOCATION

Milwaukee, WI

AT LEFT: Mark is a paid on-call firefighter with the Village of Germantown who can bring his firsthand experience of the fire services industry to the design and functionality of your facility.

TREVOR FRANK

AIA, LEED AP®, NCARB, PMP

PRINCIPAL IN CHARGE | SEH



Trevor is a principal and senior architect with more than 33 years of experience in a wide variety of building types. His passion as an architect is to design public safety facilities that provide the necessary tools to properly train, respond, and live in the environments he creates.

EXPERIENCE

- Fire Station 31 (Neenah-Menasha Fire Rescue) – Neenah, WI
- Kenosha Fire Stations No. 1, 2, 4, 6, and 7 – Kenosha, WI
- Odd Fellows Road Fire Station #9 (Liberty University Campus) – Lynchburg, VA
- Fire Stations 1, 7, and 8 – Lynchburg, VA
- New Fire Station No. 1 Design – West Bend, WI
- Police, EMS, and Fire Department Space Needs Analysis – Prairie du Chien, WI
- Police and Fire Department Master Planning – Brillion, WI
- Fire/Police Station Needs Assessment and Site Analysis Study – Rice Lake, WI
- Emergency Services Building – Black River Falls, WI
- Town Hall, Fire, and Police Station – Freedom, WI
- Discovery Center-New Library and Village Hall – Osceola, WI
- North Fire Station – Maplewood, MN
- Public Safety Facility – Bellevue, WI
- Fire and Emergency Medical Services Station Location Study – Fitchburg, WI
- Oshkosh Fire Department Operations Analysis and Long-Term Needs Assessment – Oshkosh, WI
- North East Fire Station Design – Fitchburg, WI
- North West Fire Station Design – Fitchburg, WI
- Fire Station Design – Kaukauna, WI
- New Fire Station Schematic Design – Greenville, WI
- Fire Station Study – Verona, WI
- Fire Stations 40 and 41 Renovation and Expansion – Menasha, WI
- Elkhart Lake Fire Station – Elkhart Lake, WI
- Municipal Facilities Study – Jackson, WI
- Public Safety Facility – Bellevue, WI
- Watertown Fire Station – Watertown, WI
- Sheboygan Station #3 Headquarters Master Planning – Sheboygan, WI
- Facility Assessment – Harrison, WI
- Fire Station #2 Schematic Design – Sheboygan, WI



Trevor will provide additional project oversight as principal, leveraging his significant experience with fire station design.

33
YEARS OF
EXPERIENCE



EDUCATION

Master of Science
Architecture
University of Wisconsin-Milwaukee

Bachelor of Science
Architecture
University of Wisconsin-Milwaukee



REGISTRATIONS/CERTIFICATIONS

Architect in WI, AZ, FL, GA, IA, IL, IN, KY, MI, MN, NC, ND, NE, OH, RI, SD, TN, and VA

Project Management Professional (PMP), Project Management Institute

LEED AP, U.S. Green Building Council

Architect, National Council of Architectural Registration Boards



OFFICE LOCATION

Appleton, WI

TOP: The Kaukauna Fire Station delivered two separate municipal services buildings on a single downtown urban campus.

BOTTOM: By utilizing automated software to track travel time for the Watertown Fire Station, we were able to lessen the turnout time from areas within the station to the truck floor by strategically placing access corridors and high-occupancy, high-use areas closer to the apparatus bays.

CHUCK LEIPZIG

OPERATIONS SPECIALIST | SEH

Chuck is a business development manager with years of emergency services and fire protection experience. Devoting his entire career to these services, he now works as an operations planner for fire station projects with SEH. With a fire department leadership background, he is able to recommend improvements to facilities that can increase efficiencies in areas from the apparatus bay and vehicle maintenance to dorms, training, and administrative areas. In addition to his experience in fire service, Chuck possesses the Occupation Safety and Health certification for construction safety management and oversight.

EXPERIENCE

- Fire Station 31 (Neenah-Menasha Fire Rescue) – Neenah, WI
- Sheboygan Station #3 Headquarters Master Planning – Sheboygan, WI
- Police, EMS, and Fire Department Space Needs Analysis – Prairie du Chien, WI
- Fire Station No. 4 – Kenosha, WI
- Oshkosh Fire Department Operations Analysis and Long-Term Needs Assessment – Oshkosh, WI
- Fire Department Station #4 Replacement and Memorial Park Trail Head Facility – Appleton, WI
- Fire Stations 1, 7, and 8 – Lynchburg, VA



Chuck will work with design

staff to optimize day-to-day

operations and departmental

efficiency in the design of

the station.

35

YEARS OF EXPERIENCE



EDUCATION

Bachelor of Science
Public Administration
Mount Senario College -
Ladysmith, WI

Associate
Fire Science
Mount Senario College -
Ladysmith, WI



OFFICE LOCATION

Appleton, WI



AT LEFT: In his role as Fire Chief, Chuck executed long-term strategic plans to add staffing, consolidate, remodel, and rebuild existing fire stations and negotiated professional service contracts with vendors and local firefighters' unions, including oversight of the build and funding procurement of two fire stations within the Kenosha Fire Department. Additionally, Chuck has completed studies in Engineering and Public Administration, and he has been the project manager of several programs.

BRIAN DEPIES

CLIENT SERVICE MANAGER | SEH



Brian will serve as the Village's client liaison, working with your staff and the design team to foster communication and make sure goals are met.

Brian is a Client Service Manager with extensive experience in land use planning, zoning code administration and development. Having broad-ranging experience with both public and private sectors, Brian offers clients a wide range of experience, starting from initial conceptual discussions, all the way through to project completion. Brian specializes in regional, county, and local planning as well as code administration for public sector clients. He works with citizens throughout Southeastern Wisconsin and Northeastern Illinois to assess projects, make recommendations and meet regulatory compliance. In the private sector, Brian focuses on land development projects and how to achieve project successes through understanding the client's needs and collaborating with stakeholders to help ensure the project comes to fruition.

EXPERIENCE

- Heritage Park Addition #1 (Heritage Park Development Corp) – Germantown, WI
- UW Platteville Richland Redevelopment Project (Richland County) – Richland Center, WI
- Downtown Master Plan – Elm Grove, WI
- New Warehouse Feasibility Analysis (Krier Foods) – Random Lake, WI
- Waterfront Park Planning – Random Lake, WI
- Town Planning Services – Town of Erin, WI
- Downtown Planning Assistance (Non-Metro Connections) – Waterloo, WI

32
YEARS OF
EXPERIENCE



EDUCATION

Bachelor of Science
Geography
University of Wisconsin-Whitewater



REGISTRATIONS/CERTIFICATIONS

Certified Soil Tester (CST)



PROFESSIONAL ASSOCIATIONS

- Wisconsin County Code Administrators (WCCA)
- Wisconsin League of Municipalities
- Wisconsin Builders Association
- Metropolitan Builders Association (MBA) – Developers Council



OFFICE LOCATION

Delafield, WI



AT LEFT: As a resident and the current Chairman of the Parks and Recreation Commission, Brian brings a strong commitment to the Village's future and will help your vision for this station become reality.

TAYLOR DOUGLAS

ARCHITECTURAL DESIGNER AND 3D
VISUALIZATIONS SPECIALIST | SEH

Taylor will provide conceptual designs for the facility.

Taylor is an architectural technician with experience in the design of civic/public facilities. She works with clients and project design team members to develop conceptual and schematic designs for a wide range of building types, completes test fits and space need assessments, and brings proficiency in programs such as Rhinoceros, Revit, AutoCAD, Adobe Suite, and Enscape to each project.

EXPERIENCE

- o Facility Assessment – Harrison, WI
- o Fire Station (Liberty University) – Lynchburg, VA
- o Fire Station Remodel – Neenah, WI
- o Public Safety Building – Prairie du Chien, WI
- o Fire Station and Training Facility – Oshkosh, WI
- o North West Fire Station Design – Fitchburg, WI
- o North East Fire Station Design – Fitchburg, WI
- o Fire Station Design – Kaukauna, WI
- o Fire/Police Station Needs Assessment and Site Analysis Study – Rice Lake, WI



6
YEARS OF
EXPERIENCE



EDUCATION

Master of Architecture
University of Michigan-Ann Arbor

Bachelor of Science
Architectural Studies
University of Wisconsin-Milwaukee



OFFICE LOCATION

Appleton, WI

MOLLY WAGNER PLA

LANDSCAPE ARCHITECT | SEH

Molly will lead landscape architecture design on the project.

Molly is a landscape architect and project designer with experience in educational, medical, cultural, residential, municipal, international, and master planning projects. She provides effective communication with clients and contractors from concept to construction, leveraging the use of graphics such as rendered plans, sections, elevations, plant and material boards, and construction documents to convey design intent. Her time spent working in the Pacific Northwest instilled in her a passion for stormwater and creating sustainable landscapes. Molly is proficient in AutoCAD and the Adobe Creative Suite.

EXPERIENCE

- o New Fire Station – Watertown, WI
- o New Fire Station No. 1 Design – West Bend, WI
- o Fire Station #2 Schematic Design – Sheboygan, WI
- o Bain School Site Fire Station – Kenosha, WI
- o Fire Stations 2 and 6 – Longmont, CO
- o Crystal Valley Fire Station (Castle Rock Fire Department) – Castle Rock, CO



18
YEARS OF
EXPERIENCE



EDUCATION

Master of Landscape Architecture
University of Minnesota-Twin Cities

Bachelor of Arts
Biology
Gustavus Adolphus College - St.
Peter, MN



REGISTRATIONS/CERTIFICATIONS

Landscape Architect in WI, CO, and IN



OFFICE LOCATION

Madison, WI

MATT GUNDRY PE

STRUCTURAL ENGINEER | SEH



32
YEARS OF
EXPERIENCE

Matt will lead structural design for this facility.

Matt is a structural engineer with experience designing highway structure projects, county highway shops, wastewater treatment plants, bridges, retaining walls, and industrial and commercial buildings. His highway structure design experience includes hydrology and hydraulics analysis, slab, box culverts, prestress and steel girder, timber, simple and continuous spans, sheet pile, MSE block, and CIP concrete retaining walls. Matt's building design experience includes gravity, crane, wind, and seismic; main wind force resisting system (MWFRS) and components and cladding (C&C); foundations; structural and cold-formed steel; cast-in-place and precast concrete; wood, timber, and glulam; and steel connections. He is proficient in AutoCAD Civil 3D and Architecture, Revit, MicroStation, STAAD.Pro and Foundation, GEO5, Autodesk Advanced Steel, LEAP Bridge, Hilti Profis, MathCAD, and Microsoft Office.



EDUCATION

Bachelor of Science
Civil/Structural Engineering
Michigan Technological University -
Houghton, MI



REGISTRATIONS/CERTIFICATIONS

Professional Engineer in WI, KY, MI,
MN, NC, NH, and TN



OFFICE LOCATION

Appleton, WI

EXPERIENCE

- New Fire Station – Watertown, WI
- Fire/Police Station Needs Assessment and Site Analysis Study – Rice Lake, WI
- Regional Fire Training Facility – Oshkosh, WI
- Police/Fire Station – Plover, WI
- Fire/Police Headquarters – Prairie du Chien, WI



Key Subconsultants, Experience, Responsibilities





Key Subconsultants, Experience, Responsibilities

SEH is able to provide all services outlined in the RFP in-house, but we have assembled a team that includes the following subconsultants to address your specific needs. Our teaming partners have decades of experience, millions of sq. ft. of facility design, and hundreds of millions of dollars in construction value designing functional facilities.



ATMOSPHERE | ANTICIPATED LOE 1%

Atmosphere Commercial Interiors is committed to fostering long-term business relationships. Their focus on innovative and inspired solutions guides their partnerships with architecture and design, real estate and development, and technology industries. **Atmosphere is SEH's exclusive interior design partner. We are currently working on three public safety projects and hundreds of millions of dollars in office interior renovation projects.**

Address: 1800 Scheuring Road, Suite B2,
De Pere, WI 54115



MSA | ANTICIPATED LOE 20%

MSA Professional Services, Inc. (MSA) specializes in the sustainable development of communities. They provide value with fire station projects by establishing a clear understanding of client needs, managing a rigorous QA/QC process, and focusing on long-term relationship building. This enables the smooth delivery of projects that prioritize safety and compliance, sustainable design, technology integration, and long-term cost-effectiveness. **The MSA team has been supporting SEH architectural projects for more than a decade.**

Address: 247 W. Freshwater Way, Suite 200,
Milwaukee, WI 53204



raSMITH | ANTICIPATED LOE 10%

raSmith is a multidisciplinary engineering consulting firm comprising civil engineers, structural engineers, traffic engineers, land surveyors, development managers, landscape architects, ecologists, and construction services professionals. Their services are focused on public and private sector clients' needs in design and construction, including site design, structural engineering, municipal engineering, transportation and traffic, surveying, construction services, and GIS. **raSmith is SEH's trusted partner on public safety facility design efforts, having provided site design on several of our recent emergency services projects.**

Address: 100 West Lawrence Street, Suite 306,
Appleton, WI 54911



SPECIALTY ENGINEERING GROUP LLC (STR-SEG) | ANTICIPATED LOE 1%

STR-SEG is a Wisconsin licensed engineering firm established in 1999. They specialize in building envelope consulting services including roofing, exterior walls, and hardscape (asphalt and concrete). **They provide the specialized building-envelope experience the Village requires, offering forensic evaluation of wall and enclosure systems to inform design decisions and support the successful planning of the renovation project.** This has enabled them to extend the service life of components on multiple buildings through low cost repairs and preventive maintenance while also allowing clients to plan for capital expenditures.

Address: N89W16785 Appleton Avenue, Suite 201,
Menomonee Falls, WI 53051

SCHAWN JUBERT WRID L LEED AP ID&C
 SENIOR INTERIOR DESIGNER | **ATMOSPHERE**

Schawn will lead the interior design of the station.

Schawn is a professional commercial interior designer with more than 30 years of experience in the commercial furniture and design industry. She assists clients in understanding of how people with a purpose can work effectively in their work environment. Schawn makes it a priority to stay current on new product innovations and strives to apply these products to all design opportunities. Schawn is a team player and looks forward to the next creative challenge.

EXPERIENCE

- Maplewood North Fire Station – Maplewood, MN
- Freedom Town Hall, Fire and Police Station – Freedom, WI
- Lynchburg Fire Station 9 – Lynchburg, VA
- West Bend Fire Station 1 – West Bend, WI
- Prairie du Chien Public Safety – Prairie du Chien, WI
- West Office Facility 2 Interior Renovations (Kimberly Clark) – Neenah, WI
- Green Bay Water Utility Office Renovation/Expansion – Green Bay, WI



31
 YEARS OF
 EXPERIENCE



EDUCATION

Bachelor of Arts
 Interior Design
 University of Wisconsin-Stevens Point



REGISTRATIONS/CERTIFICATIONS

Certified Leadership in Energy and
 Environmental Design with ID&C



OFFICE LOCATION

Green Bay, WI

MACEN LEONARDI PE, LEED BC+C
 PLUMBING ENGINEER | **MSA**

Macen will design plumbing systems for the facility.

Macen is a mechanical engineer with an interest in solving problems. He has more than five years of experience in the design of plumbing systems, including domestic water, stormwater and sanitary drainage, natural gas, compressed air, and fire protection systems for public and private clients alike – as well as for multiple school districts across the state of Wisconsin.

EXPERIENCE

- Tomah Fire Station – Tomah, WI
- Kenosha Fire Station 4 – Kenosha, WI
- Little Chute Fire Station – Little Chute, WI
- West Bend Fire Station – West Bend, WI
- McFarland Public Safety Building – McFarland, WI
- Pleasant Prairie Police Station – Pleasant Prairie, WI



11
 YEARS OF
 EXPERIENCE



EDUCATION

Bachelor of Science
 Mechanical Engineering Milwaukee
 School of Engineering



REGISTRATIONS/CERTIFICATIONS

Professional Engineer in WI
 LEED AP BD+C accredited



OFFICE LOCATION

Milwaukee, WI

LAURA GILBERT PE

SENIOR ELECTRICAL ENGINEER | MSA

Laura will lead the design of electrical systems for this project.

Laura's broad expertise includes lighting design, electrical distribution, and the intricate design of fire alarm and telecommunications systems. She has a proven track record of training and mentoring her team members, fostering an environment of continuous learning and professional growth. Laura's proficiency is further demonstrated in her significant contributions to numerous LEED-certified edifices, two of which have achieved the prestigious Platinum certification. Her work reflects her commitment to sustainable and energy-efficient design principles. Her portfolio boasts a diverse range of projects, including educational institutions, libraries, religious establishments, and public safety buildings.

EXPERIENCE

- New Fire Station – Watertown, WI
- Public Safety Building – Prairie du Chien, WI
- Kenosha Fire Station 1 New Station – Kenosha, WI
- Kenosha Fire Station 4 Replacement – Kenosha, WI
- Fitchburg East Fire Station – Fitchburg, WI
- Fitchburg West Fire Station – Fitchburg, WI



20
YEARS OF
EXPERIENCE



EDUCATION

Bachelor of Science
Architectural Engineering
Milwaukee School of Engineering



REGISTRATIONS/CERTIFICATIONS

Professional Engineer, WI, KS, MI, IA,
IL, GA, and MN



OFFICE LOCATION

Plymouth, WI

JASON TESTIN DES

SENIOR HVAC ENGINEER | MSA

Jason will lead the design of HVAC systems in the station.

Jason has broad experience with a variety of project types including municipal buildings, schools, hospitality, manufacturing, water parks, and even a monastery. Jason originates designs, equipment specifications and brings knowledge and judgment to every project he oversees. He has a lot of experience in the design of geothermal heat pump systems. As these systems develop and gain greater acceptance in the community, Jason expands his knowledge and understanding of the technologies involved.

EXPERIENCE

- Watertown Fire Department – Watertown, WI
- Tomah Fire Station – Tomah, WI
- Kenosha Fire Station 4 – Kenosha, WI
- Freedom Public Safety Building – Freedom, WI
- Sheboygan Fire Station #1 Renovations – Sheboygan, WI
- Kenosha Fire Station – Kenosha, WI
- Fitchburg East Fire Station – Fitchburg, WI
- Kaukauna Fire Department – Kaukauna, WI



23
YEARS OF
EXPERIENCE



EDUCATION

Bachelor of Science
Mechanical Engineering
Tri-State University-Angola, IN



REGISTRATIONS/CERTIFICATIONS

Designer of Engineering Systems, WI



OFFICE LOCATION

Mequon, WI

BRAD HARTJES PE
SENIOR CIVIL ENGINEER | raSMITH

Brad will lead the site design and stormwater management planning and design efforts.

With 27 years of civil engineering experience, Brad has specialized in water resource, municipal and site development projects. He has focused extensively on water resource aspects, such as hydrologic and hydraulic analysis, comprehensive watershed studies, stormwater management reviews, flood control and flood improvement and stormwater detention and compensatory storage determination. From a site development perspective, Brad's projects have included the residential, commercial, and industrial markets for both the public and private sectors. He uses his skills in site plan development, stormwater management permitting, grading and earthwork analysis, plan and profiles, utility layout and design, wetland coordination, and geotechnical coordination to help ensure success for his clients' projects.

EXPERIENCE

- Dept. of Public Works Phase IV Expansion Site Design – Kaukauna, WI
- Fire Station 4 Site Design – Kenosha, WI
- Green Bay Water Utility Building Expansion Site Design (Green Bay Water Utility) – Green Bay, WI
- Fire Station Site Design – Freedom, WI
- Municipal Utility Bldg. Site Design – Black River Falls, WI

TROY HARTJES PE
CIVIL ENGINEER | raSMITH

Troy will provide the site design for this project.

Troy has nearly 30 years of experience in municipal and site development projects. Troy's extensive project experience includes urban and rural roadway rehabilitation and construction; sanitary sewer and water main system design; stormwater management and conveyance systems; water and sewer system planning; lead service replacements; stormwater utilities; comprehensive drainage plans; turf fields and sports complexes; and business park, commercial site, and residential subdivision design. Troy has experience helping clients prepare capital improvement budgets; construction specifications; bid documents; public reports and assessment schedules; CMOM reports; NR 216 compliance reports and development reviews; MMSD private lateral infiltration and inflow administration; and DNR SDWL for lead services and development reviews.

EXPERIENCE

- Northeast Interceptor Sewer – Germantown, WI
- Goldendale Road and Holy Hill Road Interceptor Sewer and Transmission Main – Germantown, WI
- Holy Hill Roadway and Utilities – Germantown, WI
- High Point Pass – Germantown WI
- Bavarian Woods Subdivision – Germantown, WI



27
YEARS OF
EXPERIENCE



EDUCATION

Bachelor of Science Civil Engineering,
University of Wisconsin-Platteville



REGISTRATIONS/CERTIFICATIONS

Professional Engineer in WI
Certified Floodplain Manager



OFFICE LOCATION

Appleton, WI



30
YEARS OF
EXPERIENCE



EDUCATION

Bachelor of Science
Civil Engineering (Transportation and
Municipal Emphasis)
University of Wisconsin-Milwaukee



REGISTRATIONS/CERTIFICATIONS

Professional Engineer in WI
American Society of Civil Engineers
American Council of
Engineering Companies
American Public Works Association



OFFICE LOCATION

Milwaukee, WI

JOSHUA FLEMING PE

CIVIL ENGINEER | raSMITH

Josh will support the site design for this project.

Josh is a civil engineer with four years of experience in site design, municipal roadway improvements, and construction inspection. He specializes in pavement and utility design, with advanced proficiency in surface modeling for site layouts and ADA-compliant infrastructure. His work consistently meets and exceeds design standards, supporting high-quality, accessible infrastructure development.

EXPERIENCE

- Fire Station – Little Chute, WI
- Fire Station – Prairie du Chien, WI
- Fire Station Remodel – Neenah, WI
- Fire Station #18 Parking Lot Rehabilitation – Oshkosh, WI
- Fire Station #19 Parking Lot Rehabilitation – Oshkosh, WI



4
YEARS OF
EXPERIENCE



EDUCATION

Bachelor of Science
Civil and Environmental Engineering,
Water Resources Emphasis
South Dakota School of Mines
and Technology



REGISTRATIONS/CERTIFICATIONS

Professional Engineer in WI



OFFICE LOCATION

Milwaukee, WI

BRUCE FLATER RRO

FORENSIC ENGINEER | STR-SEG

Bruce will provide assessment and recommendations for the fire station remodel and expansion.

Bruce has a keen eye for envelope construction, can accurately assess wall systems, and provides recommendations and budgets for a wide range of facilities. Bruce has experience in all phases of the design and construction of roof and wall assemblies. Through several hundred projects on industrial, commercial, municipal, and institutional facilities, he has gained applied expertise in a variety of other building envelope components that directly or indirectly affect wall performance. Bruce is well versed in state-of-the-art wall systems and materials, including masonry, cladding, insulation, and air/vapor barriers. He is a member of the Roof Consultants Institute and is pursuing his certification as a Registered Roof Observer.

EXPERIENCE

- AASD North Cluster Roof Assessment (Appleton Area School District) – Appleton, WI
- 2023 Roof Assessment (Outagamie County) – Appleton, WI
- Wastewater Treatment Plant Exteriors Survey – Appleton, WI
- Lena Plant Roof Assessment (Saputo Cheese) – Lena, WI



35
YEARS OF
EXPERIENCE



EDUCATION

Theoretical and Practical Applications
of Modified Bitumen Roof Systems
State Institute for the Bavarian
Roofing Craft



REGISTRATIONS/CERTIFICATIONS

RRO



PROFESSIONAL ASSOCIATIONS

RCI



OFFICE LOCATION

Milwaukee, WI

RUSSELL MOHNS PE

FORENSIC ENGINEER | STR-SEG

Russ will oversee envelope and wall system evaluations for the fire station remodel and expansion.

Russ is a project engineer and principal at SEG. He brings more than 40 years in the engineering field to each project. His strengths are in the evaluation, analysis, and specification of envelope and wall systems, with a focus on inspection and performance review. Russ has extensive experience assessing masonry assemblies, precast concrete panels, exterior insulation finish systems (EIFS), metal cladding, and related sealant interfaces. His work includes identifying deficiencies, verifying compliance with design intent, and providing recommendations for repair or restoration to help ensure long-term durability and integrity.

EXPERIENCE

- Roof Discovery (Aramark Uniform Services) – Vinton, VA
- Governmental Center Roof Assessment (St. Croix County) – St. Croix, WI
- 2023 Roof Assessment (Vanderbilt Office Properties) – St. Louis, MO
- Various Facilities Roof Assessment (State of Wisconsin DFD) – Madison, WI



44
YEARS OF
EXPERIENCE



EDUCATION

Milwaukee School of Engineering



PROFESSIONAL ASSOCIATIONS

National Society of Professional Engineers

Wisconsin Society of Professional Engineers



OFFICE LOCATION

Milwaukee, WI



Proposed Services





Proposed Services

Based on our understanding of community and departmental needs, our team is prepared to get to work on this project immediately. Our plan to deliver this project in a timely and cost-efficient manner is outlined below and on the pages to follow.

PARTNERSHIP APPROACH TO FIRE STATION DESIGN

With emergency services and municipal buildings comprising nearly all of the work that we complete, our team is uniquely qualified to take on this project and we're eager to get started on your behalf.

It is important to create a partnership in the early stages of planning a fire station facility that pulls together our highly technical professionals with representatives from the Fire Department and Village who will work on this from start to finish.

The experience and professional credibility that this team brings to the process will help garner the support and respect of Germantown's residents and stakeholders. We are working with several other communities on similar efforts, we understand the work involved, and we know the process for successfully getting these projects completed. This work is focused on delivering 21st century facilities that solve today's complex issues within the fire service.

With this experience and insight, we have included our understanding of some of the key considerations of this project.

UNDERSTANDING

The Village of Germantown is planning an expansion and renovation of its existing Fire Station at N115W18752 Edison Drive. The current facility, approximately 9,600 sq. ft., was built in 2000–2001 and includes four drive-through bays, offices, dorms, restrooms, a training room, and an adjacent kitchen/dayroom. Additional support spaces near the apparatus bays are used for storing and maintaining the Department's gear and equipment.

Originally constructed as the Village's second fire station, it has served as the only operational station for the



past seven years. The 2.63-acre site is located within an industrial park, close to several high-hazard areas. The site also contains the "Survive Alive House," which will be demolished as part of this project, and a three-story training tower, which will remain.

When Fire Station #2 was originally built, the Department operated under a volunteer model. Over time, it has transitioned into a primarily career-based Fire Department offering paramedic-level EMS services. To accommodate additional staff, the station has undergone minor renovations, including updated interior finishes and reconfigured spaces for more offices. Recently, beds have been added to offices to support increased staffing.

With the closure of Station 1, the drive-through bays have been modified to require apparatus to "back in," making room for additional trucks and equipment. As staffing and apparatus continue to grow in the coming years, the station now requires a significant expansion.

This project represents the first phase of a two-part plan to address the Fire Department's needs. Phase one will meet short-term requirements (0–5 years), while phase two will focus on long-term needs through the construction of a new fire station within the Village.

CRITICAL SUCCESS FACTORS

Based on our understanding of the project, we have identified the following factors critical to the project's success:

- **Accommodating Increasing Staffing Levels.** In recent years, staffing levels have increased as the Department transitioned to a career-based model. This growth has pushed the existing living quarters beyond capacity. The project must provide solutions for adequate dormitories, offices, training areas, restrooms, storage, and dayroom/kitchen spaces.
- **Building Envelope Remediation.** Fire Station #2 was built with single-wythe exterior masonry walls. These porous, poorly insulated materials have raised health concerns for building occupants. SEH is partnering with a building envelope specialist to help ensure that recommended solutions for the existing exterior walls effectively address these issues.
- **Decontamination Facilities.** The fire station currently lacks modern decontamination amenities considered best practice in today's facilities. This project should incorporate these features to protect staff health by reducing exposure to carcinogens and pathogens encountered during emergency incidents.
- **Phased Approach.** SEH has successfully completed projects – and currently has others under construction – that required phased work to maintain full operational capability. For this project, the design team will collaborate with Village stakeholders to evaluate solutions that keep the station functional throughout construction, prioritizing occupant safety at every stage.

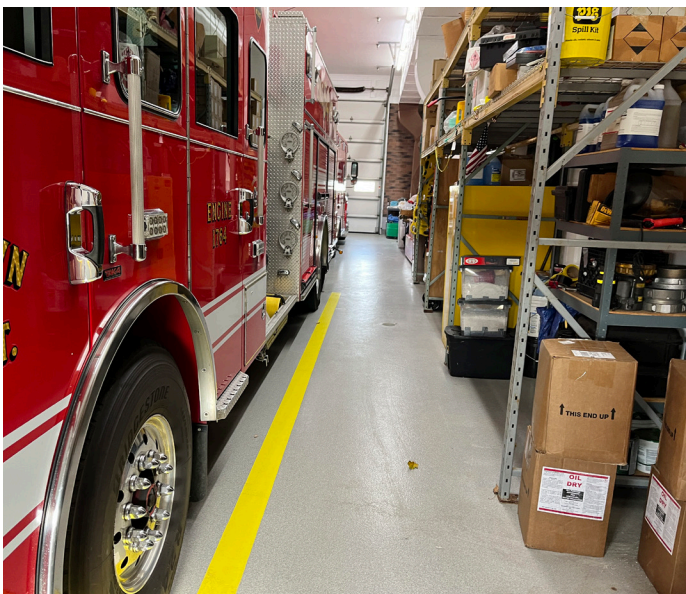

- **Visibility/Aesthetics.** The Village takes pride in maintaining a distinctive architectural aesthetic for its governmental and prominent buildings along the Mequon Road corridor. The existing station facade reflects this standard, and any addition or alteration should seamlessly blend with the established design. Our team brings extensive experience in context-sensitive design, with numerous examples of modern, highly functional fire stations that complement the unique character of their communities.

PROJECT PROCESS

The Village is requesting proposals from qualified architect/engineer consultants to assemble and lead a team to perform professional services for the design of the expansion and renovation to Fire Station #2. Design services shall include architectural design, structural engineering, site civil engineering, stormwater management design, landscape design, MEP design, interior design, and telecommunication design.

This process will include the following phases:

- 1. Schematic Design.** We will review documentation assembled from previous exercises, produce solutions for unresolved items, prepare room data sheets, and present to committees, Village Board, and public information meetings.
- 2. Plan Development.** We will prepare plans, specifications, cost estimates, and contract documents. We will be responsible for obtaining all applicable federal, state, and local permits.
- 3. Consultant Construction Administration.** Bidding and construction administration services by a Construction Manager are yet to be determined. The Village intends to hire a Construction Manager that is a firm or team other than any member of the design team. The A/E Consultant will assist the selected CM to provide full construction administrative services throughout construction.

The intent of the Village is to retain a design team that will develop design, bidding, and construction documents and specifications in sufficient detail to proceed with the next step in construction. After Village approval of the selected schematic designs, the design team will be authorized to begin plan development and proceed with the creation of construction documents.

Prior to the 30% plan development stage, the Village is expected to select a Construction Manager to manage bidding, construction management, and documentation of the project, and to provide input on the plan development and specifications.

YOUR FIRE STATION FACILITIES

The SEH team has been discussing Germantown's plans for a fire station expansion and renovation, and we understand the challenges the Department has been facing, which include:

- Protection area of 36 square miles, and nearly 21,000 residents
- Efficiency of response from the current site, compounding with the evolutionary changes in the fire service industry
- Cancer prevention through decontamination and isolation incorporating hot, warm, and cold zone best practices
- Future-proofing the station to accommodate the ever-growing gender mix
- Providing proper spaces for training that include more computer-based and distance learning platforms
- Understanding the Fire Department's needs to "future proof" your investment by assessing the needs of a demographic shift in available work pool, as well as anticipating needs of a growing community
- Coordination and phasing of the demolition and construction to maintain Fire Department operations throughout construction

Additionally, recruitment in fire service is at an all time low, so it magnifies the need for a facility that is capable of recruitment and retention that fosters pride in the Fire Department and the community.

Our proven approach will address these challenges head on and will result in a new community-supported fire station that the Village and Fire Department staff can be proud of.

CONSENSUS BUILDING

The consultant plays a critical role in building consensus among team members. As project manager and primary contact, Mark Zvitkovits will lead discussions emphasizing the importance of developing a design and plan that the entire project team and community can support. Gathering input and feedback helps ensure that all team members feel engaged and understand their role in shaping the process and outcomes.

Consensus-building methods include assigning specific tasks to team members during meetings, which they complete and present at subsequent sessions. This approach keeps the entire design team informed and fosters commitment to the project's goals.

The SEH team builds consensus-driven decision making into all of the projects we design. Our most recent example of getting stakeholder input to build consensus and commitment can be seen in the public outreach and programming of the fire station in West Bend, Wisconsin. We encourage you to contact the Mayor, the Construction Manager, and the Fire Chief responsible for the programming of the facility to discuss our approach to consensus formed design (see p. 7).

PROCESS AFTER APPROVAL

The process our team follows from the approval of the schematic design through the approval of final design is one of collaboration and involvement by the design team, as well as the key project players representing the Fire Department, Construction Manager, and Village. Once the preliminary design and cost estimates are completed and presented to the Village and community for consideration, we work to build consensus among leaders and residents in the community. This consensus is key to working toward permission to start the final design – known as the construction document phase.

Once permission to move into final design is granted, we revisit the schedule and discuss any adjustment to key milestone dates. We also build in time to include team drawing reviews, QA/QC checks, and cost updates at 60% completion of documents and just prior to issuing the plans for bid. Checking the cost against the design at these critical milestones is important in keeping the project on schedule and on budget.

ADDING VALUE

The SEH team adds value to these projects by bringing the experience of 125 completed fire station and public safety facility projects to assist with the programming and design of your facilities.

Mark brings experience in your department and is joined by an operations specialist that is a retired fire chief with more than 30 years in the fire service industry. Together, they bring a perspective of the fire services industry into programming and discussions of the functionality and practicality of the design. They also share industry insights as to where things are trending in the fire services industry. This is a valuable perspective and voice at the table when we are

reviewing how the fire services operations interact with the architecture of the facility.

Additional value is represented in the utilization of software technology that allows us to calculate travel time as fire staff are responding from all parts of the station to the apparatus bay floor. Our previous example of this mapping illustrates the value and being able to identify and maximize efficiency in the day-to-day movement in operations within the firehouse. We recently used this programming software when laying out the interior spaces for the West Bend Fire Station. By utilizing this automated software to track travel time, we were able to lessen the turnout time from areas within the station to the truck floor by strategically placing access corridors and high-occupancy, high-use areas closer to the apparatus bays.

Our team will also find cost-effective site design solutions through detailed analysis of site layout, grading, utilities, landscaping, and stormwater management.

SUMMARY OF SERVICES

PHASE 1 – SCHEMATIC DESIGN

- Project Kickoff: Make introductions, identify roles and responsibilities, develop schedule and key milestone dates, discuss budget and goals for the project
- Review previously completed study analysis and determine if there have been any changes to the recommendations or the program of the fire station building
- Conduct space programming for the building interior and revisit the size and function of the previously programmed building areas
- Prepare room data sheets for every space identified in the schematic design
- Facilitate staff meetings to explore and discuss building components
- Coordinate with the Village's geotechnical engineer for soil testing
- Produce a site survey to identify public and private utilities existing topography and site features
- Make recommendations regarding alternate materials, methods, and features that offer cost savings while maintaining quality
- Make recommendations for construction phasing to maintain an operational facility during construction.
- Assist with and attend four public information meetings for comments



- Present schematic plans and materials exhibits to the Public Safety Committee, Building Oversight Committee, and Village Board prior to proceeding to Phase 2
- Assist Germantown Fire Department and Village with the selection of a Construction Manager through a regimented RFP selection process

PHASE 2 – PLAN DEVELOPMENT

- Upon approval, prepare all construction documents, specifications, schedules, and cost estimates
 - The fire station is to remain fully operational throughout construction
 - Design and contract documents will be developed to reflect this approach
- Make recommendations regarding sustainable options as prescribed by LEED standards; we understand that building will not achieve LEED certification
- Identify and recommend infrastructure to “future-proof” the station for technology, utilities, space, and staffing changes
- Identify and incorporate best practices for the health, safety, and wellness of the building occupants
- Identify and recommend EVP installation and/or other traffic management requirements associated with emergency vehicles
- Complete and present design documents at intervals of 30%, 60%, 90%, and 100% completion with estimates and specifications at each stage
 - Final design documents shall comprise of all necessary drawings, details, schedules, and specifications for bidding and construction

- Attend Plan Commission and Village Board meetings necessary for site plan approval
- Submit and obtain approvals for the site and building plans from the Village of Germantown, SAFEBuilt, and all other authorities of jurisdiction
- Provide Village with electronic CAD and PDF files of contract documents
- Cooperate and coordinate with the Village for Media releases; all media releases intended for public view will be reviewed, approved, and released by the Village

DETAIL OF PROPOSED SERVICES: SCOPE OF WORK

SEH and our skilled group of consultants will produce much-needed upgrades to the existing fire station for the Village of Germantown.

PROJECT KICKOFF MEETING

With all key team members are in attendance, the SEH team will:

- Make introductions
- Discuss roles and responsibilities
- Understand decision-making process
- Discuss schedule and tasks to be completed
- Discuss budget and potential funding sources

PHASE 1 – SCHEMATIC DESIGN *(all disciplines)*

During the schematic design phase, SEH will:

- Develop the strategy/schedule and workflow with the design team and Village
- Review analysis and documentation assembled during previous exercises to guide design
- Using industry standards, project experience, and input from Fire Department and Village Staff, conduct appropriate space programming for the building interior, including basic information such as sizes, space requirements, workflows, activities, and special uses
- Facilitate meetings with Department and Village staff as needed to develop basic components and planning of the building program, including building systems, equipment, materials, and code compliance to support service needs
- Facilitate a listening session with end users, including female firefighters of the Department to make sure

their voices are heard in the programing and design of the station

- Make recommendations regarding sustainable options to consider in the construction of the facility as prescribed by LEED standards
- Create and provide schematic site plan sketches, elevations, renderings, schematic cost estimates, and conceptual project schedules as necessary to create the conceptual project design
- Make recommendations regarding the potential to have additional training space added to the facility
- Make recommendations regarding alternative materials, construction methods, or design features that offer potential cost savings while meeting desired quality standards
- Once the Village and Department have accepted the recommended conceptual design as outlined here within Phase 1, proceed to Phase 2

PHASE 2 – PLAN DEVELOPMENT *(all disciplines)*

Prior to this phase, the team will review and revise any information that was gathered during the Village Board review and presentation in Phase 1. We will:

- Prepare all construction documents, civil engineering plans, specifications, final construction cost estimates, and final timelines for completion of the project
- Attend all applicable public meetings associated with the review and approval of the proposed design
- Refine the building materials, systems, and enhanced functional and operational adjacencies
- Integrate stakeholders' input responding to environmental, life cycle cost, security issues, budget, and schedule considerations



- Develop the schematic architectural, landscape, and civil concepts into final construction documents with consideration of sustainability, life cycle maintenance and durability, phasing, budget, schedule, and constructability
- Once the Village Board has accepted the recommended final design as outlined here within Phase 2, proceed to Phase 3

PHASE 3 – CONSULTANT CONSTRUCTION ADMINISTRATION

Upon approval of detail design documents, the SEH team will proceed with assisting the Construction Manager, Germantown Fire Department, and the Village in bidding the project to qualified general contractors. During this phase, we will:

- Assist the Construction Manager in preparing all the bid documents and specifications suitable for public bidding according to applicable standards
- Respond to all questions posed by prospective bidders during the construction bid process
- Prepare and distribute any necessary addenda
- Attend a pre-bid conference to inform bidding contractors of the details regarding the bid process
- In collaboration with the Construction Manager, make a recommendation to Germantown Fire Department and the Village on bid award considering their evaluation of the bids based on bidders' qualifications, compliance with bid requirements, and price
- Coordinate all construction administration services through the Village, Department, and Construction Manager, who will lead the construction administration effort
- Review shop drawings, material submittals, product data, and associated testing reports
- Respond to contractor questions/RFIs throughout the construction process
- Attend preconstruction and regular construction progress meetings throughout duration of construction, documenting site observations and design conformance
- Provide field observation reports to the Village, Construction Manager, and contractor
- Review proposed changes or requests, assess impacts, and issue clarifications as needed
- Attend critical inspections
- Review Contractor pay applications are consistent with work completed and meet contract documents
- Perform the project closeout activities
- Conduct final walk-through inspection
- Develop punch list and verify corrective action
- Issue certificate of compliance with state and local authority having jurisdiction
- Assist with commissioning and training
- Generate final record drawings, based on as-built documentation from contractor
- Attend 11-month warranty walk through following construction completion



PROJECT SCHEDULE

TASK	2025	2026								2027	
	D	J	F	M	A	M	J	J	A	J	
Award Design Contract (12.15.25)	■										
Design Agreement Executed (12.31.25)	■										
Kickoff Meeting (1.5.25)		■									
Phase 1 – Schematic Design		■	■								
Village/Department Preliminary Site/Building Plan Review			■								
Phase 2 – Plan Development – 30% Plans and Estimate				■							
Village/Department DD Site/Plan Review				■							
Phase 2 – Plan Development – 60% Plans and Estimate					■						
Village/Department 60% Site/Plan Review					■						
Phase 2 – Plan Development – 90% Plans and Estimate						■					
Village/Department 90% Plans and Estimate						■					
Bi-Weekly Team Coordination Calls During Design		■	■	■	■	■	■				
100% CD Drawing & Site Plan Review & Approval-SAFEBuilt Review						■	■				
Bidding							■				
Contractor Award								■			
Phase 3 – Construction									■	■	

Building a Better World for All of Us[®]

Sustainable buildings, sound infrastructure, safe transportation systems, clean water, renewable energy, and a balanced environment. Building a Better World for All of Us communicates a company-wide commitment to act in the best interests of our clients and the world around us.

We're confident in our ability to balance these requirements.

JOIN OUR SOCIAL COMMUNITIES





Over 300
Programming/
Feasibility Studies

Over 150
facilities
designed
& built

Over 140
years of
combined
public safety
experience

ARCHITECTURAL & ENGINEERING SERVICES



November 24, 2025

Proposal for

REMODEL & EXPANSION

OF FIRE STATION #2



Village of Germantown, WI

TECHNICAL PROPOSAL

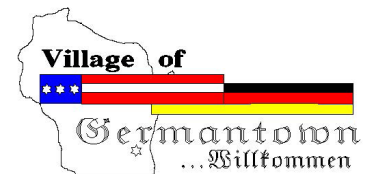

Table of Contents

1. Letter of Introduction/
Statement of Interest
2. Firm's Information
3. Key Individuals, Qualifications
& Experience
4. Key Subconsultants,
Experience & Responsibilities
5. Proposed Services

PRICE PROPOSAL
UNDER SEPARATE COVER



01

Letter of Introduction/ Statement of Interest



November 24, 2025

Germantown Fire Station 2
N115W18752 Edison Drive
Germantown, WI 53022

SUBJECT: PROPOSAL FOR PROFESSIONAL DESIGN SERVICES FOR VILLAGE OF GERMANTOWN FIRE STATION #2

Dear Evaluation Team,

Wendel Architecture, P.C. (Wendel) is a national architecture, engineering, energy efficiency, and construction management firm that has been providing services to communities throughout the US since 1940. With our multi-disciplined regional office located in Eau Claire, WI, we are pleased to submit our proposal to the Village of Germantown for design services for the remodel and addition of Fire Station #2.

Although Wendel is still a relatively new name for Southeastern Wisconsin, the history of working in the area, as well as the references, will show our vast experience working in your region. As you will see from this proposal, our experienced staff have designed and worked on many projects throughout Wisconsin that you may recognize.

Five Bugles Design, our award-winning public safety design team at Wendel, is uniquely positioned to provide design services for Germantown's Fire Station #2. We are excited to offer a team of multi-disciplined experts from across the country who focus on the design of such facilities, but with our project leadership and production coming directly from Wisconsin.

Some of the unique and specialized services we offer your team include:

- **Public Safety Specialists:** Wendel recently acquired Mitchell Associates Architects, who work exclusively on public service facilities, including fire stations, EMS, and shared facilities. The merger of Wendel's Five Bugles Design and Mitchell Associates Architects brings two nationally known public safety experts with decades of emergency services experience combined into one team. Our combined teams have worked together in the past and feed off each other's strengths and knowledge. We now bring this wealth of experience to the Village of Germantown and increase our team's ability to provide clients with over 140 years of combined public safety experience. Together, we have a matchless, industry-leading portfolio of award-winning, research-based, innovative facilities. Collectively, the team has completed construction documents on over 150 public safety projects across the United States, with 42 of those being in Wisconsin alone.
- **National Expertise:** Our team is an industry leader in public safety design. With members of our staff being station design judges, presenters at national conferences, and taking part in NFPA committees, we bring a wealth of knowledge to the Village. Our team strives to design to NFPA 1500 and NFPA 1851, which other architectural firms may neglect to bring to the table. This building is not just another commercial facility; it is intricately designed, taking the health of public safety individuals and their families into great consideration.
- **Our unique Immersion Process to reduce project schedule and costs:** This is our hands-on concept development process used at the project's outset that allows us to work collaboratively with the entire project team to rapidly redefine and establish the development plan and set the entire project up for success. The following link provides more information about our Immersion process.
<https://wendelcompanies.com/immersion/>



Within our proposal, you will find details on our experience and unique value that includes:

- Our team has bid over \$50 million worth of public safety construction in Wisconsin in the last 4 months, with another \$40 million bidding in the Spring of 2026. Our schedule aligns perfectly with the Village of Germantown's needs, and we can provide a wealth of knowledge regarding the costs of these facilities.
- We feel our team is one of the most experienced emergency services design firms in the United States, located right here in Wisconsin.
- A unique collaborative process that combines the extensive knowledge of experienced specialists who have completed these facilities throughout the Country. This includes local building industry leaders collaborating with our clients to create projects that consistently exceed project expectations.
- We have the local knowledge of working with local construction managers in both the CMa and CMaR models.
- Single point accountability in design through construction completion with one Project Manager leading the way.

The key to any successful project is the experience and leadership qualities of the people who do the work. We have assembled a team of experts with significant experience in fire station planning and design. Wendel is pleased to submit this proposal in the hope that our design professionals, with their unique experiences and clear understanding of your vision for this project, can work collaboratively with you to create a project that brings significant value to the Village of Germantown for decades to come.

I will serve as the Principal-in-Charge for this project. I can be reached by email at rkrzyzanowski@wendelcompanies.com or by telephone at 715-559-0297. We look forward to your review of our qualifications and answering any questions you may have.

Best Regards,
Five Bugles Design

A handwritten signature in black ink, appearing to read "Robert Krzyzanowski".

Robert Krzyzanowski
Director of Emergency Services/Principal-in-Charge
rkrzyzanowski@wendelcompanies.com
Ph: 715-559-0297



02

Firm's Information





CORPORATE PROFILE

In 1940, Leon Wendel started a small civil engineering firm. Over the last eight decades, Wendel has grown into a full-service architecture, engineering, energy efficiency, and construction management firm that delivers customized solutions and turnkey projects in innovative ways.

Today, we boast a full complement of professionals in every engineering discipline, including a robust energy efficiency department; a talented team of architects and landscape architects; construction managers; planners; and interior designers. Our team is based out of 15 offices, is licensed in 38 states, and has over 350 employees dedicated to upholding our four core values: team first; quality; first-class communication; and promises made, promises kept. At the heart of those values is our belief that we can **create a better world through knowledge and leadership.**

WENDEL SERVICES:



ARCHITECTURE

- Interior Design
- Landscape Architecture
- Master Planning
- Historical Preservation



ENGINEERING

- Civil
- Electrical
- Environmental
- Mechanical
- Municipal
- Structural
- Transportation
- Railroad
- Alternative fuel solutions/CNG
- Water/wastewater retrofits
- Land surveying
- Geographic information systems (GIS)
- Planning



ENERGY EFFICIENCY

- Energy audits
- Commissioning
- Professionally Assisted Performance Contracting
- Alternative Funding/Grant Programs
- Retrofit and implementation design
- Green building design
- Measurement & savings verification (M&V)
- Renewable technologies



CONSTRUCTION MANAGEMENT

- Master builder
- Progressive Design/Build
- Design/Bid/Build
- Construction Management at Risk (CMaR)
- CM Agent
- GMP Design/Build

Map Of Wendel Offices
(Wendel Icons)



WENDEL TIMELINE

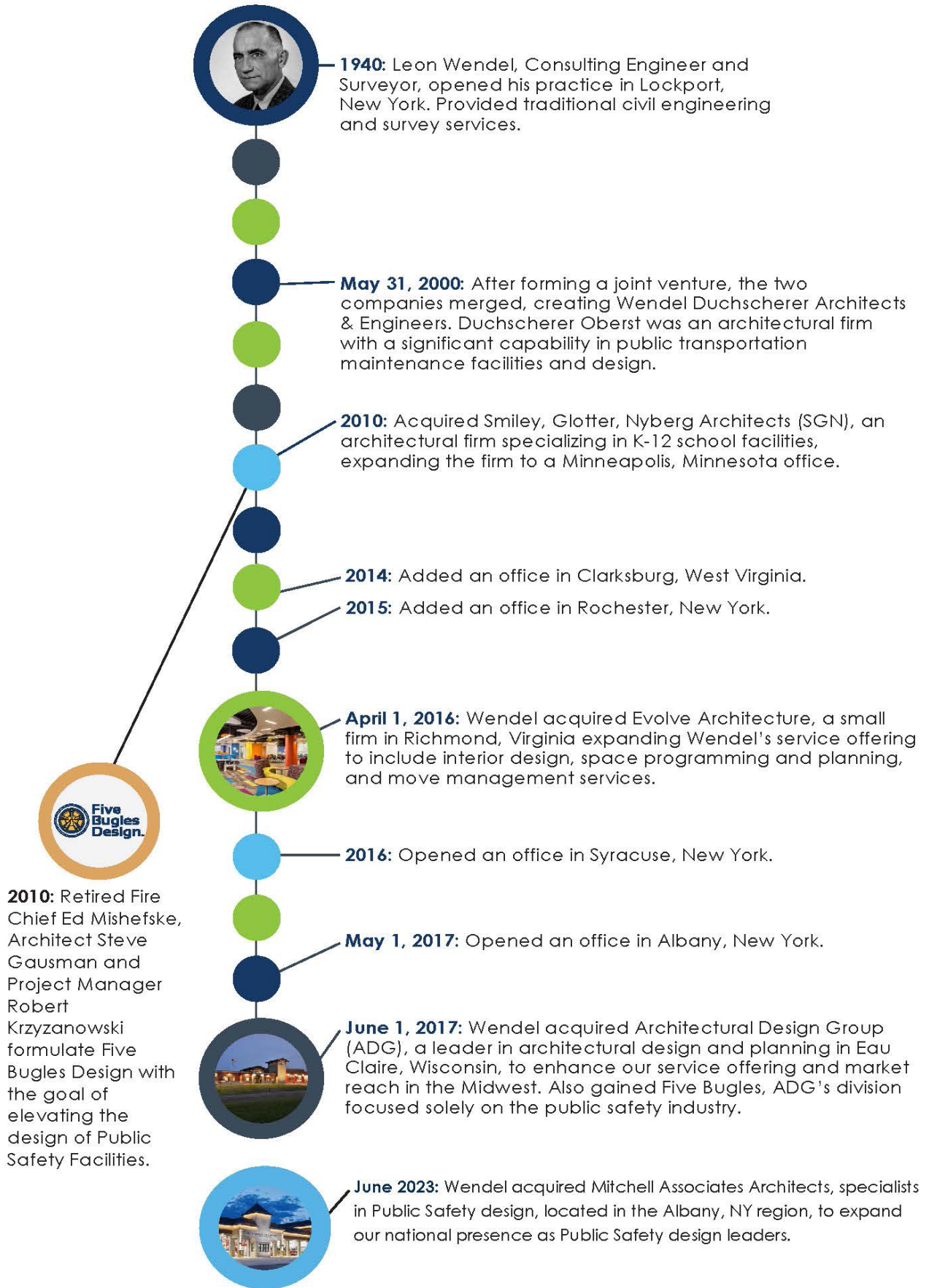

Firm Contact

Robert Krzyzanowski
P: (715) 559-0297
E: rkrzyzanowski@wendelcompanies.com

Name & Location

Five Bugles Design + Mitchell Associates
Architects Wendel's award winning
Public Safety Team
204 E. Grand Avenue, Suite 200
Eau Claire, WI 54701
fivebuglesdesign.com

Year Established

Wendel: Established in 1940
June 1, 2017: Wendel acquired
Architectural Design Group (ADG),
a leader in architectural design and
planning in Eau Claire, Wisconsin to
enhance our service offering and market
reach in the Midwest. Also gained Five
Bugles, ADG's division focused solely on
the public safety industry.

Legal Status

Licensed to perform Architecture &
Engineering services in Wisconsin

Firm Ownership

Corporation

Staffing

Total Staff: 350+
Eau Claire: 17

Primary Firm Location for this Project:

204 E. Grand Avenue, Suite 200
Eau Claire, WI 54701

BUILDING ON A VISION

Five Bugles Design was formed to provide planning and design services to the public safety service industry. We understand that public safety buildings are truly a unique building type. Our focused design team is comprised of members whom, both collectively and individually, are among the most experienced public safety design professionals in the Industry.

UNMATCHED PUBLIC SAFETY FACILITY DESIGN EXPERIENCE

Our award-winning team of architects and active emergency services specialists have experience throughout the country. We focus on exceeding our clients' expectations and providing exemplary project management services, all while "speaking your language."

COLLABORATIVE. FOCUSED. CLIENT DRIVEN. COMMUNITY CONSCIOUS.

Making a positive and lasting impact on the people and communities we serve is at the core of what we do. We believe that by getting to know our clients, their needs, and the communities they serve, we're able to collaborate as a design team to provide winning solutions that go far beyond the obvious. Our goal is that the facilities we design today will serve our clients for decades to come.

EMERGENCY SERVICE DESIGNERS

The architects, engineers, and designers that are a part of our Five Bugles Design team have experience leading municipalities through the process of design. These individuals learn from every project they have been part of, with some having decades of experience. Our team then takes what we have learned, good or bad, and puts that information forward to our new clients.

The design of emergency services facilities is a very intricate and detail-oriented process. Our clients have to be detail-oriented in their everyday job of saving lives; we expect our team to understand that small details matter in a facility where every second counts.

We pride ourselves on function over frills, however, we have the diversity in our portfolio to satisfy any client's needs and desires. **Emergency services design is the only thing that the Five Bugles Design team focuses on and they have dedicated their careers to this cause.**

IN-HOUSE EMERGENCY SERVICE SPECIALISTS

The Five Bugles Design team includes a number of Emergency Service Specialists. These individuals are both active and retired public safety personnel with extensive background in the management and operations of fire and police departments of all types and sizes (career, paid-on-call, combination).

Most importantly, they have built stations for their own departments and understand the challenges created by the necessity of blending facility demands with budgetary concerns.

Our Emergency Service Specialists use their decades of experience to lead our unique programming process. They will direct a conversation that explores your individual operational and facility challenges, breaks those challenges down into their respective building components, and then work with our experienced architects and planners to define and quantify those elements with the goal of creating an accurate depiction of the built environment that will ultimately become your new facility.

Our Emergency Service Specialists also work for the State as advisors, fire inspectors, and educators. These items allow our team to see how operations are working throughout the State, what new technologies are coming out, and pros/cons on how technology is impacting public safety.

MITCHELL ASSOCIATES ARCHITECTS

In 2023, Wendel, home of the award-winning Five Bugles Design, also acquired Mitchell Associates Architects, specialists in Public Safety design, to expand our national presence as Public Safety design leaders.

Mitchell Associates Architects works exclusively on public service facilities – fire stations, EMS, and shared facilities. With over 20 years of experience, they have produced award-winning fire station designs and more than 190 projects addressing over 330 public safety facilities throughout the Northeast, Eastern Seaboard, Missouri, Texas, and Alaska. With expertise in renovation and new construction, their comprehensive services range from feasibility studies, site selection, building design, public approval, and full project management through construction.

This expansion increases our team’s ability to provide clients with public safety projects. Together, Wendel’s Five Bugles Design and Mitchell have a matchless, industry-leading portfolio of award-winning, research-based, innovative facilities. Collectively, the two companies have completed over 330 public safety projects across the United States.

Joining forces to become a single team provides the ability to leverage all of our talents and expand our capabilities while continuing to produce quality work.



TRAINING

Our team has extensive experience in regional training facilities as well as creating staff training opportunities within a public safety facility.

At the core of any successful and efficient emergency services protection program is public safety facility training. Community expectations for delivery services over the last decade have grown to a level never anticipated. Emergency medical services, hazardous materials, confined entry rescue, fire ground management techniques, communications, domestic terrorism and international terrorism are not hypothetical scenarios, but realities. Designing these high-risk but low-frequency training opportunities into the new fire station is critical to a department's level of ability to face the new challenges these situations present.

Our teams are national leaders with our innovative approach of incorporating training programs into building design. In our discussions during the initial programming and space orientation phase of the building process, we spend a great deal of time talking about the department's existing training program. We take this time to gather as much information as possible and then offer design solutions that include in-house training space. Firefighters and Police Officers will be on hand during training sessions if a major emergency occurs.



One of the training opportunities that we have included in numerous facilities is the use of a training tower for both drying fire hoses and for practicing in a multistory internal/external training platform.

Master planning of emergency services facilities involves taking the entire scope of the project into account, not just the building. Our team has worked with all of our clients to design training needs into their overall site plan, whether that includes live burn towers, extrication training needs, confined space training, simulated shoot houses, etc. Each project comes with a need and/or idea for training and our team has acted on integrating those ideas into an eventual design.



PERSONNEL DECONTAMINATION: EMERGING TRENDS

Over the past decade, there has been an increase of cancer diagnoses for those men and women in the fire services, as well as for their loved ones at home. In an attempt to help keep firefighters and their families healthy, we have created a personnel decontamination process which separates the fire station into zones (hot and cold), and therefore helps to reduce the spread of cancer-causing contaminants.

This process includes decontaminating trucks, gear, and of course, people. Restricting contaminants to the hot zones and having staff transition to the cold zones ensures that they are free of those contaminants after responding to an emergency.

Our award-winning team members have proven their gear expertise in the design and development of decontamination spaces. By constantly pushing the limits and creating (not just following) the emerging trends, we are regularly given the opportunity to speak to our peers and emergency services professionals at conferences throughout the country, as well as publish articles in national publications showcasing our unique and user-focused decontamination processes.

Robbie Krzyzanowski is a featured writer on personnel decontamination in Firehouse Magazine, and Bob Mitchell lectures on it at the FDSOA, FIERO and Firehouse station design conferences, as well as the national FIERO PPE research conference.

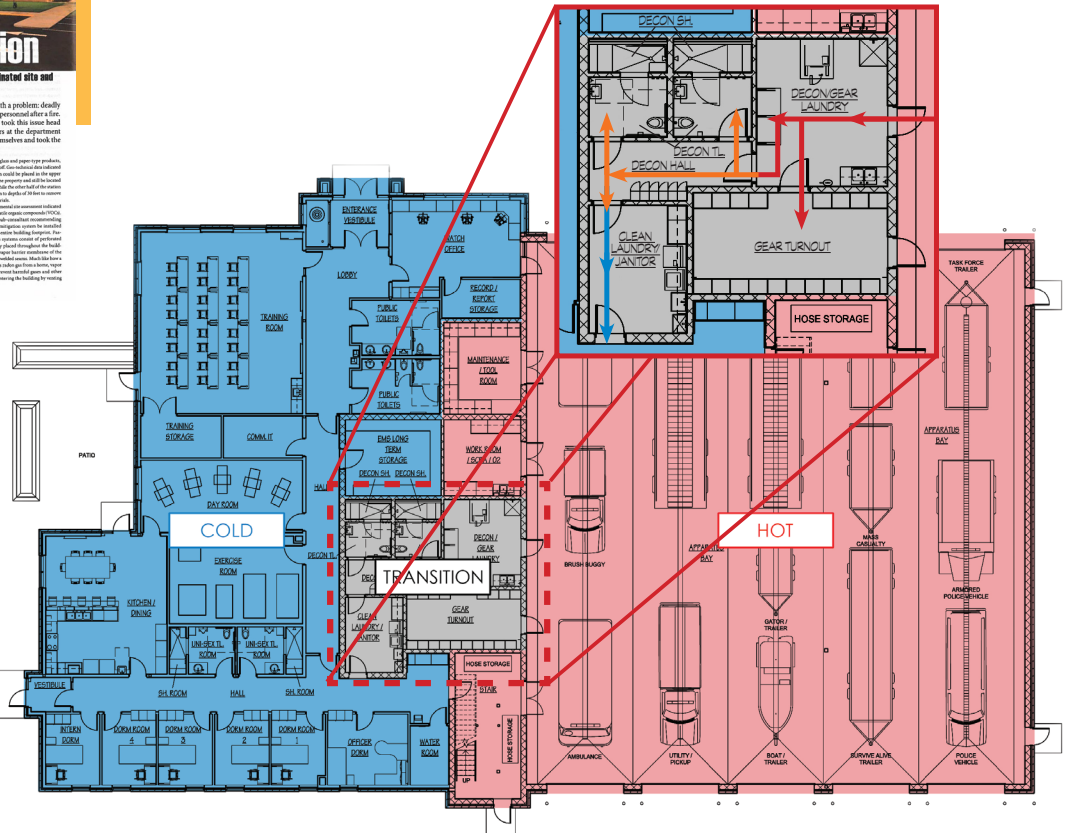

PUBLIC ENGAGEMENT

Public engagement is critical to our philosophy of gaining project support from project participation. Successful public campaigns are the result of effective planning, transparent communication of a value-based solution, and support at the local level by municipal staff and officials.

- Public hearings and neighborhood groups provide opportunities for interactive progress updates with concerned citizens.
- The local press presents an opportunity to present the project in a positive light at chosen times throughout the project.
- Web-based project sites are available to provide meeting notes and project updates.
- Every community is different and presents a different set of challenges to the communications of project information and project approval processes. We will work with your team to develop a combination of the elements that works best.
- Assistance with social media postings.
- Referendum Assistance.
- Graphics for monthly news letters and websites.
- Produce mailers, postcards, and newsletters to be mailed to public.
- Create fliers to be posted around community.



TOWN OF GREENVILLE, WI

NEW FIRE & SAFETY BUILDING

OTE AUGUST 14, 2018

WHY NOW AND WHY DO THESE NEEDS EXIST?

The needs and the challenges facing the Greenville Fire and Safety department and our community are not unique. The emergency vehicles have increased in size and complexity since the current fire station was built. The requirements and public expectations placed on our volunteer and full-time fire and safety personnel has increased dramatically over that same time period. The number of calls for service has increased and the environment in which we expect our emergency responders to work in has become increasingly more dangerous. The incidence and risk of several types of cancers is significantly higher for emergency personnel who we rely upon to preserve both life and property of those who live, work, or visit our community. The needs of this department has been well documented in studies dating back to 2010. The current Fire and Safety station no longer meets the needs of the department or our community and a new fire station will significantly add to the safety of those who serve.

The 2015 referendum included two other projects (Town Hall and Public Works) for a total of 10.5 million. The current referendum being considered specifically addresses the needs of the Fire and Safety department independently for an estimated cost of 6.5 million. The cost to construct a new modern fire station has been reduced with this new design and will overcome current and future challenges of the department and community for well over the next 50 years. The costs to construct a new fire station will increase by 3 to 5 percent annually until it is built. The majority of residents surveyed support the need for key aspects of this specific project.

ESTIMATED TAX IMPACT

REFERENDUM AMOUNT	\$6,500,000
ESTIMATED AVG MILL RATE OVER 20 YEARS	\$.25/\$1,000 of Assessed Value
TAX IMPACT ON PROPERTY WITH FAIR MARKET VALUE OF:	
\$100,000 Property	
Annual Impact	\$25.00
Monthly Impact	\$2.09
\$150,000 Property	
Annual Impact	\$37.50
Monthly Impact	\$3.13
\$200,000 Property	
Annual Impact	\$50.00
Monthly Impact	\$4.17
\$300,000 Property	
Annual Impact	\$75.00
Monthly Impact	\$6.25

Note: Planning estimates only. Significant changes in market conditions will require adjustments to current financing plan. Rates subject to change.

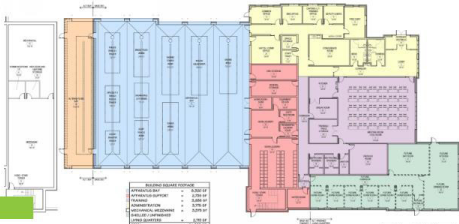

Questions, comments or concerns can be directed to:
Town Administrator - Joel Gregozeski
(920) 757-5151 or joelg@townofgreenville.com
Visit TownofGreenville.com for more information.



CONTACT US

The Greenville Facilities Committee
Andy Peters, Dean Culbertson, Greg Kippenhan,
Amy Vosters, Dan Dibbs, Brad Borgen, Larry Bentle,
Tim Lambie, Eric Kitowski



TOWN OF GREENVILLE, WI

NEW FIRE & SAFETY BUILDING

OTE AUGUST 14, 2018

WHY NOW AND WHY DO THESE NEEDS EXIST?

The needs and the challenges facing the Greenville Fire and Safety department and our community are not unique. The emergency vehicles have increased in size and complexity since the current fire station was built. The requirements and public expectations placed on our volunteer and full-time fire and safety personnel has increased dramatically over that same time period. The number of calls for service has increased and the environment in which we expect our emergency responders to work in has become increasingly more dangerous. The incidence and risk of several types of cancers is significantly higher for emergency personnel who we rely upon to preserve both life and property of those who live, work, or visit our community. The needs of this department has been well documented in studies dating back to 2010. The current Fire and Safety station no longer meets the needs of the department or our community and a new fire station will significantly add to the safety of those who serve.

The 2015 referendum included two other projects (Town Hall and Public Works) for a total of 10.5 million. The current referendum being considered specifically addresses the needs of the Fire and Safety department independently for an estimated cost of 6.5 million. The cost to construct a new modern fire station has been reduced with this new design and will overcome current and future challenges of the department and community for well over the next 50 years. The costs to construct a new fire station will increase by 3 to 5 percent annually until it is built. The majority of residents surveyed support the need for key aspects of this specific project.

REFERENDUM QUESTION 1

Shall the Town of Greenville, Outagamie County, Wisconsin be authorized to issue pursuant to Chapter 67 of the Wisconsin Statutes, general obligation bonds in an amount not to exceed \$6,500,000 for the public purpose of financing the constructing and equipping of a new Fire and Safety Building?

ACCORDING TO THE LATEST TOWN OF GREENVILLE RESIDENT SURVEY:

- 67% (Highest Percentage) of residents of Greenville rate the "Fire Protection and Prevention Services" as the most important of services provided by the Fire and Safety Building as the number one priority (10%) and other remaining projects.
- 59% (Highest Percentage) of residents identified that each project previously identified should be handled as separate projects with potential separate time tables.

DON'T FORGET TO VOTE ON AUGUST 14TH!
Visit TownofGreenville.com for more info.

THE GREENVILLE FACILITIES COMMITTEE
Andy Peters, Dean Culbertson, Greg Kippenhan,
Amy Vosters, Dan Dibbs, Brad Borgen, Larry Bentle,
Tim Lambie, Eric Kitowski

Questions, comments or concerns can be directed to:
Town Administrator - Joel Gregozeski
(920) 757-5151 or joelg@townofgreenville.com
Visit TownofGreenville.com



PUBLIC SAFETY BUILDING

LEED PROJECTS:

- Buffalo, MN
- Marshfield, WI
- Menomonie, WI
- Chisholm, MN.

OTHER LEED PROJECTS WITHIN

OUR FIRM:

- Village of Westfield, NY
- City of Beacon, NY
- Village of Fredonia, NY
- Syracuse, NY
- Village of Horseheads, NY
- City of Phoenix, AZ
- Lynchburg, VA
- Savannah, GA
- Niagara Falls, NY
- Blacksburg, VA
- Rapids, MI
- Lorton, VA
- Binghamton, NY
- Bridgeport, CT

SUSTAINABLE DESIGN

Standard design features include:

- Natural Light
- In-Floor Heat
- Building Envelope Exceeds Building Code Requirements
- Other exciting technologies:
Photovoltaics, Solar Walls, Water Reclamation Systems, Green Roofs, White Roofs, Geothermal, Wind Power, Purchasing Renewable Energy Credits from Local Energy Co-Ops, Etc.

INDUSTRY LEADERSHIP & ENVIRONMENTAL STEWARDSHIP

As a design and construction firm, we recognize that our projects can have a significant impact on the environment and we are passionate about advancing opportunities that raise the bar on sustainability. This carries through into how we operate as a company, how we pursue our work, and how we interface with the world in our daily lives. Wendel's sustainability legacy will be how we respected the environment and our community.

Our Sustainability Charter identifies both short- and long-term sustainability goals, and establishes metrics to evaluate our successes, identify areas for improvement, and creates a roadmap for greater engagement in initiatives across departments and offices.

As part of the Wendel Strategic 2020 Plan, a "Stewards of the Environment" leadership group was created to help drive the "practice-what-we-preach" element into a larger energetic group. Wendel has set six goals to help prioritize sustainability efforts for increasing energy efficiency, increasing staff awareness, increasing engagement with the community, and creating a platform to track and document efforts. Progress will be evaluated annually in conjunction with implementation milestones. The Stewards team provides on-the-ground support to implement the initiatives, collect data, and lead communication and reporting efforts.



CITY OF BEACON FIRE DEPARTMENT



ITHACA FIRE DEPARTMENT

"Our design teams have recently completed the design and have begun construction on a No-Fossil Fuels emergency services facilities in Beacon, NY and Ithaca, NY. Wendel strives to protect the environments in which we live, work and play."



REFERENCES & PROJECTS



REFERENCES

The public safety clients and associated projects referenced below are examples of the experience our team brings to your project, whether a study or complete design. Every one of these projects brings with it a certain set of knowledge gained that can ultimately be passed on to our clients.

Lakeside Fire-Rescue

(Edgerton, WI)
Randall L. Pickering, Fire Chief
pickeringr@edgertonfire.com
(608) 332-9462 (cell)

Watertown Fire Station Study

Emily McFarland (Former Mayor)
(920) 998-5874
mcfarland@gmail.com

Knoxville Public Safety Building

Heather Ussery, City Manager
City of Knoxville
305 S. Third St.
Knoxville, IA 50138
(641) 828-0550
www.knoxvilleia.gov

Village of Harrison

Chad Pelishek, Village Manager
W5298 State Road 114
Harrison, WI 54952
(920) 989-1062, ext 109

Green Bay Fire Department

Matthew Knott, MS, EFO, CFO
Fire Chief
(920) 448-3278
Matthew.Knott@greenbaywi.gov

Baraboo Area Fire & EMS District

Kevin G. Stieve, Fire/EMS Chief
City of Baraboo Emergency
Management Director
(608) 356-3455
kstieve@baraboofireandems.com

Superior Fire Department

Camron Vollbrecht, Fire Chief
3326 Tower Avenue
Superior, WI 54880
(715) 395-1680
Direct: (715) 395-1644

Town of Greenville

Eric Kitowski, Deputy Fire Chief
(608) 358-1942
Ekitowski@townofgreenville.com

La Crosse Fire Department

Blane Neher, Assistant Chief
726 5th Ave S
La Crosse, WI 54601
(608) 789-8042
neherb@cityoflacrosse.org

Sheboygan Fire Station #2 & #3

Casey Bradley, City Administrator
City of Sheboygan
828 Center Avenue
Sheboygan, WI 53081
(920) 459-3287
casey.bradley@sheboyganwi.gov

Village of Suamico

Alex Kaker
City Administrator
(940) 434-2212
villageadministrator@suamico.org

Cloquet Area Fire District

Jesse Buhs, Fire Chief
Cloquet, MN
(218) 380-9840

Facilities Study

2021

Fire Chief Todd Eckes
Wisconsin Rapids Fire
Department
(715) 421-6278
teckes@wirapids.org

WISCONSIN RAPIDS FIRE DEPARTMENT

Wisconsin Rapids, WI

Five Bugles Design was hired by the Wisconsin Rapids Fire Department (WRFD) to perform a study of their two existing stations focusing on the existing condition of the facilities, space needs analysis for current and future needs, conceptual design options to renovate their facilities to meet those needs and provide cost estimates for those proposed concepts. Along with those tasks, the team also reviewed how to create gender equity at both facilities and how to increase personal decontamination areas.

During the study, three options were created for Station 1, the simplest of which the department immediately implemented, and two options were created for Station 2. It was recommended to the city that they move forward with a hybrid option for Station 1, and Option A for Station 2. The design was completed in Fall 2021.

At Station 1, a new living quarters addition was created. This addition created seven individual dorm rooms along with a new larger kitchen, dining room, and day room. These spaces have direct access to a new EMS apparatus bay. This new bay houses three ambulances and connects to the existing apparatus bay and the existing station. The spaces vacated in the existing facility have been renovated to create

a new training room, two new offices, a battalion chief office/dorm room, and a personal decontamination suite including three single occupancy all-gender toilet shower rooms. These toilet rooms are dual purpose – serving decontamination needs as well as general day-to-day needs. This new decon suite serves the entire department, not just those housed at Station 1.

The renovation at Station 2 was bid as an alternate project. This project converted the large multi-user shower, sink, and toilet room into two single-occupancy all-gender toilet shower rooms, with a residential laundry space in between. The design was completed in the Fall of 2021, with completion and final occupancy in the Summer of 2022, all while the department stayed in the station during construction.



Station Highlights:

- Five drive-through apparatus bays
- State-of-the-art personal decontamination,
- Icc500-rated storm shelter
- Training tower
- Watch room
- 40-Person training room

New Construction

Project Cost: \$6.5 million

Kris Dockendorf
City Administrator
City of Cold Spring
(320) 685-3653
kdockendorf@coldspring.govof-
fice.com

COLD SPRING PUBLIC SAFETY BUILDING

Cold Spring, MN

The new Cold Spring fire station, located in the river district of downtown Cold Spring, was designed as a replacement facility for the volunteer department. The new station will feature five drive-through apparatus bays, state-of-the-art personal decontamination, a ICC500-rated storm shelter, training tower, watch room, and a large training room, with seating for forty.

The facility's location brought several challenges that were resolved during the design process, including granite, a challenging site footprint, contaminated soils, and aesthetic convenience.

Located on just 1.84 acres of land, the property included a large granite outcropping on the eastern portion of the site, and a privately owned parcel of land, approximately 30' wide, which juts into the western property line approximately 40'. These two barriers created a pinch point for the facility, dictating its width and location. The facility was designed to maximize the frontage onto Main Street, while still maintaining all bays as drive-throughs and attempting to avoid blasting granite as much as possible.

Having previously been used by a manufacturer and brass refinery, contaminants were found in the soils. Soils on site were required to be removed from under the footprint of the facility and tested if they were taken off site. Any soils that tested positive for contaminants were removed to approved landfills.

Finally, the exterior façade of the building needed to work within the required convenience. The covenant dictated material usage and colors, heights, the percentage of glazing on the façade, and allowable roof types. This required reviews with the City and Cold Spring Granite for approval prior to design.

The new station will upgrade the department with on-site training, decon spaces, and safe apparatus areas. Special touches were also included in the project, including the maltase cross on the stations' façade, which will be craved and sandblasted out of granite by the fire chief.

The project was bid in the late Summer 2024 and will open for occupancy in Fall 2025.



Station Highlights

- Public safety building with city, police and fire services.
- Shared training/council chambers
- State-of-the-art decontamination area
- Evidence processing and storage
- Squad parking
- Full career police, fire hall city hall

Completion Date: Fall of 2026

Project Cost: \$16 million

Contact:

Heather Ussery | City Manager
City of Knoxville
305 S. Third St. Knoxville, IA 50138
Ph.(641) 828-0550
www.knoxvilleia.gov

KNOXVILLE PUBLIC SAFETY BUILDING

City of Knoxville, Iowa

The City of Knoxville, Iowa contracted with the public safety team of Wendel to provide a conceptual study for a new facility to house their existing police department, city hall, and fire department and. Our team also provided GIS services to ensure that this new facility would be located correctly in the city regarding response times.

After completion of the study and GIS, the Five Bugles team is now in the early phases of designing construction documents of the new Knoxville Municipal Building for the City's departments. The new facility is approximately 38,120 SF of which 9,110 SF is considered shared spaces such as the sixty-person training room/council chambers, exercise room, lobby, mechanical, break rooms, records storage, and conference rooms.

The Police Department area will include an office for the chief and administrative captain, with a separate entrance for the staff from the public., Offices for the patrol lieutenants, sergeants, and patrol officers are provided near each other for proper flow. The facility will include proper evidence intake, evidence processing, and evidence storage. The locker room facilities will include toilet showers/changing rooms, and the facility will also provide quartermaster storage, duty bag storage and squad parking full for six squads.

For the Fire Department, the administration area will include five offices and a separate entrance for staff from the public as was done for the police. The living quarters is completed with a kitchen/dining/day room that will be open concept and be flanked by sleeping quarters for nine individuals. Apparatus support areas include proper Cold/ Hot zone decontamination areas, PPE Storage, SCBA clean and Fill, workshop area, EMS Storage, and a hose tower for drying hose. A watch office and command office will overlook the entire apparatus bay, which will have four bays for ambulances and an additional four bays for fire apparatus with room to grow in the future.

On the City Administration side of the project, the plan includes a front lobby area where administrative staff will welcome guests from both the city services side and the law enforcement side. City government will include five offices as well as an open area that will provide seating for four additional staff.

Design is slated to continue through the spring and summer of 2025 with groundbreaking occurring in the fall of 2025.



Station Highlights:

Station 1:

- 32,680 SF
- New Construction
- Two-Story
- Satellite Station with Headquarters
- Will have space for third-year off-duty interns
- Estimated cost of work: \$16.3M
- Estimated total project cost: \$19.3M

Station 2:

- 20,260 SF
- Renovation & Addition
- Single-story facility
- Space for first-or second-year off-duty interns at adjacent facility

Estimated cost of work: \$8.5M

Estimated total project cost: \$10.1M

Station 3:

- 16,840 SF
- New Construction
- Single-story

Estimated cost of work: \$8.7M

Estimated total project cost: \$10.4M

Station 4:

- 21,175 SF
- New Construction
- Single-story
- Space for first- or second-year off-duty interns

Estimated cost of work: \$10.5M

Estimated total project cost: \$12.6M

Phase: Design Development

Anticipated Opening: Phased: 2026 - 2028

Contact: Randy Pickering, Fire Chief,
pickeringr@edgertonfire.com

LAKESIDE FIRE DISTRICT

Edgerton, WI

The Lakeside Fire District is comprised of 11 municipalities in south central Wisconsin. They serve a geographical area of 220 square miles across three counties, 19.7 miles of Interstate 39/90, and portions of Lake Koshkonong, as well as the Rock, Yahara, Badfish, and Koshkonong rivers. Founded in 2023, the new district is now in need of multiple facilities to cover their diverse and vast district.

Prior to the formal founding of the District, Five Bugles Design worked with several of the individual municipalities to create concept plans for new stations. Once the district formed, these concepts, as well as their locations, were reconsidered. Ultimately, the department determined it was best to design and construct four stations, as well as a headquarters facility.

Station 1: Newville & District Administration is designed as a new construction, two-story facility, in Newville, WI. This location is centralized within the district, is adjacent I39/90 for quick access, and is located just off the base of the Rock River and Lake Koskonong. Being designed for equity, the Satellite Station 1 will comprise the lower level of the facility. This will be comprised of living quarters for both on-call staff and three off-duty third-year interns, personal decontamination (decon), apparatus support, and will have direct access to the apparatus bays. The upper level of the facility is designed to accommodate the districts administration; small, dedicated space for the Wisconsin Department of Transportation; and central training for the district.

Station 2: Edgerton is an existing facility that will be partially razed, renovated, and an addition will be constructed. This facility will feature living quarters for the

on-duty staff, a small training room, station administration, apparatus support spaces, and apparatus bays. The off-duty first- or second-year interns will be housed in a facility located on the adjacent property.

Station 3: Milton West is a new construction, single-story facility with a mezzanine. This station will be constructed on a greenfield site, located along side the local high school. Special consideration was given to this site due to the high school traffic, which can dramatically increase at peak times. An additional drive will be constructed to the north, in case the school traffic will impact response. Additionally, with the internship program being a two- or three-year program (two for fire-fighter, three for paramedic), this will be the only station that will not house interns.

Station 4: Milton East will be a new construction, single-story facility with a mezzanine. This facility will share a site with Town of Milton's Town Hall facility. By sharing a site, the District and the Town will be able to share amenities such as parking, a training room, and on-site water treatment. Station 4 will house six first- or second-year interns, as well as the on-duty staff.

Designed for equity between the stations, all stations will be designed with: living quarters, including kitchen, dining, day rooms, and a mothers / quiet room; individual dorms; individual all-gender toilet / shower rooms; personal decontamination including gear lockers, gear laundry and all-gender toilet / shower rooms; apparatus support; apparatus bays; training; and station administration including private offices, and a watch room with direct access to the apparatus bay.

The four buildings will all also share similar aesthetics and finishes for both the exterior and the interior finishes.

With the projects currently in design, it is intended that the four facilities will be constructed in an overlapping, phased approach; beginning with Station 4 and the Town Hall, then Station 3 and Station 1, and finally the renovation and addition of Station 2.

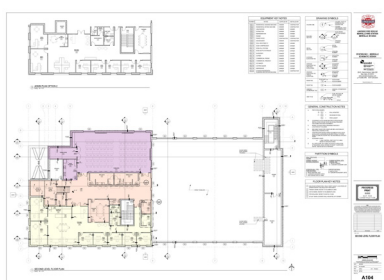

Station Highlights:

- 28,000 sf
- Two Story Facility
- Administrative & Living Quarters
- Training Requirements
- Exercise Room
- Decontamination Room
- Two Fire Poles

\$7,750,000 (estimate)

\$7,213,518 Cost of Work

**New Construction
Completed**

Contact:

Jeff Schott, Fire Chief
schottj@cityoflacrosse.org
O: (608) 789-7261
M: (608) 780-1757

LA CROSSE FIRE STATION NO. 2

LA Crosse, WI



Designed as a replacement facility for its existing Station 2, the new La Crosse Station 2 will serve the city's west side, housing a two-engine company and the department's administrative team. This 20,000 SF facility is to be located on a one-acre site alongside the University of Wisconsin - La Crosse. With the heavily trafficked La Crosse Street to the north, Oakland Street to the west, and UW-L to the east and south, the overall site design and layout of the facility focused on maintaining user safety, the need for a highly functional and response driven station and a "no back-side" aesthetic for the station.

The site was divided up with response on the north side of the facility (facing La Crosse Street), apparatus return and shift-working parking on the southeast side, and administration and visitor entry and parking on the southwest portion of the property. The facility was shifted as far west on the site as possible to maintain

grass and separation between the station and UW-L. Additionally, all four sides of the facility were given consideration to be appealing. Inside the facility, the overall layout continues to focus on safety for the responders and creating division between these three user groups. To do so, the first floor of the station is for responder use only and houses the watch/command office, dorms, personal decontamination spaces apparatus support spaces, and the exercise room, which opens to the apparatus floor for additional space. The station's small lobby directs visitors to the second level administration areas through and elevator and set of stairs.

On the second level, a small reception space adjoins conference room. Directly off reception is the department's administrative space, including private offices for the fire chief, assistant chiefs, division chief, fire investigators offices, an open office, the battalion chief's office, and a shared shift officer's office. The second level of the facility also houses the remaining living spaces, including the kitchen and dining space, a rooftop patio, and the day room. Two fire poles are located in these living spaces to allow responders to quickly move to the apparatus bay from the second level. Station 2 was completed in the Spring of 2023 with full occupancy occurring in June 2023. Wendel was contracted to perform all design and construction management activities using our Master Builder Approach.



Station Highlights:

- 13,816 sq ft, two-story facility
- Comprehensive hot zone, warm zone, and cold zone separation.
- Living quarters that include six gender neutral, single occupant bunkrooms, as well as a kitchen/dining/day room, TV room, and study.
- Classroom and physical training, watch room and offices for the station lieutenants and captain
- Full decon laundry with hot zonesthowerers.
- EMS and firematic storage, and a mechanic's workroom

Completion Date

Summer 2025

Project Cost

\$14.3 Million

Client Contact

Robert Covert, Fire Chief
Ithaca Fire Department
rcovert@cityofithaca.org
(607) 272-1234
M: (607) 227-2683

ITHACA FIRE DEPARTMENT

ITHACA, NY

Wendel's Public Safety Design Team provided programming and design for an innovative new fire station that advanced the City of Ithaca toward their climate action goals. The Ithaca East Hill Substation replaces the City's 1960's vintage College Town station. Wendel's scope included structural, mechanical, electrical, plumbing and fire protection engineering. In 2023, Wendel's role expanded to also provide Construction Management services. These services include preconstruction planning and estimating, as well as project management during construction.

The new fire station is 100% electric, operating carbon-free energy systems, a key sustainability element. The station will operate a ground-source heat pump system to maximize energy efficiency, reduce operating costs, and eliminate the need for a fossil fuel-based heating system.

The building is entirely heated and cooled through the combination of a water cooled variable refrigerant flow (VRF) systems and a water-to-water heat pump serving in-floor radiant heating. Terminal fan coil units and ductless split units serve each space. An energy recovery ventilator (ERV) ventilates the apparatus bay. Domestic water is provided through air-cooled heat pump water heater with electric backup.

The station is also designed with R-values above code, numerous details to reduce heat loss, and heat recovery ventilation. The project meets the 2020 NYS Building Codes, the NYS Stretch Energy Code and the Ithaca Green Code.



Station Highlights:

- 28,000 SF
- Two Story Facility
- Administrative & Living Quarters
- Training Requirements
- Exercise Room
- Decontamination Room
- Two Fire Poles

\$8,200,000 (estimate)

\$8,171,791 Cost of Work

**New Construction
Completed**

Contact:

Jeff Schott, Fire Chief
schottj@cityoflacrosse.org
O: (608) 789-7261
M: (608) 780-1757

LA CROSSE FIRE STATION NO. 4

La Crosse, WI



In the winter of 2021 and well into design of La Crosse Fire Station No. 2, our team was hired by the City of La Crosse to begin design and ultimately perform construction management services on the City's new Fire Station No. 4, located on the City's North side.

The project consisted of the City purchasing seven homes next to their existing fire station No. 4 to ultimately raze and become home for the new fire station. Original concepts also had the existing station no. 4 being demolished to allow for the construction of station no. 4, however the city elected to keep the existing station, allowing it to remain and potentially be purchased by a private entity.

This four bay station includes living quarters for eight personal, state of the art decontamination areas, exercise room and a watch office overlooking the front apron and apparatus bays.

Also included in the design is a community room with a generous lobby to display the department's rich history. Police entities are included in the design to allow for a "satellite" station for their use in lieu of traveling back to the main police headquarters.

The project completed construction in the summer of 2024 with Wendel serving to perform all design and construction management activities using our MasterBuilder Approach



BEACON FIRE HEADQUARTERS

Beacon, NY

Completion Date
November 2024

Project Cost
\$10,334,000

Reference
Chief Thomas Lucchesi
Beacon Fire Department
1140 Wolcott Avenue
Beacon, NY 12508
M: (845) 857-3225
tlucchesi@beaconny.gov

The City of Beacon Fire Department is a blended department with career and volunteer firefighters who worked out of three stations. The City wanted to explore consolidation for the fire department and potentially the municipal offices. Between 2006 and 2022, the Wendel Public Safety Team completed five feasibility studies on consolidating two existing fire stations or building a new fire headquarters. We determined renovations and additions to the centrally located Lewis Thompkins Hose Company Station were viable solutions.

We ensured the building met the needs of the firefighters, increased public safety and aligned with the City of Beacon's sustainability goals by incorporating energy-efficient systems and green building materials.

To promote a healthy station, the project includes effective isolation of contaminants from living and office space, a user-friendly decontamination facility for firefighters, and increased heat recovery to remove carcinogenic byproducts of combustion brought back to the station from fire scenes.

Firefighters benefit from sleeping quarters isolated from operational noise to reduce sleep deprivation as well as peaceful living quarters to reduce the pressures of PTSD. There is adequate space to work around the fire apparatus without risk of injury and adequate storage to ensure there are no unnecessary trip and fall hazards on the floor.

During renovations, the existing building was used, preserving the structure and basic construction materials of the station. Exterior materials and detailing are consistent with the historic character of the Hudson River shoreline town. Construction materials were chosen based on maximum lifespan and ability to be restored, allowing the building to be used for more than 100 years.

The station is 100% electric, carbon-free energy systems. It uses a ground-source heat pump system to maximize energy efficiency, and reduce operating costs, eliminating the need for a fossil fuel-based heating system. It has R-values well above code requirements, and high efficiency heat recovery ventilation.

After



Before

OCONTO FALLS - FIRE STATION

Oconto Falls, WI

Station Highlights:

- 18,700 Sf Volunteer Fire Station
- Five Drive-Through Apparatus Bays
- Physical And Classroom Training Spaces
- Modified Training Tower
- Personal Decontamination Spaces
- Watch Office
- Conference Room
- Offices

\$6,538,031

New Construction

2024

Contact:

Tim Magnin, Fire Chief
City of Oconto Falls Fire Department
98 Jackson Street
PO Box 70
Oconto Falls, WI 54154

The City of Oconto Falls hired Five Bugles Design for a conceptual study of which set the overall stage of an award of a Healthcare Infrastructure Capital Investment Grant through the state of Wisconsin in July of 2023. The City of Oconto Falls then worked directly with the Five Bugles Design team to design their new 18,700 SF volunteer fire station. The awarded grant had rigorous time line requirements that needed to be met, causing our talented team of

professionals to leverage their experience and expertise to streamline the design process. The result is a facility that meets the needs of this contemporary volunteer department, including five drive-through apparatus bays, physical and classroom training spaces, a modified training tower, personal decontamination spaces, a watch office located right off the apparatus bay, a conference room, and offices. A future addition was planned for, which would include dorms and living spaces if the need ever arose.



Station Highlights

- 24,000 SF public safety
- New fire station with 4 apparatus bays,
- Training tower and state-of-the-art decontamination spaces
- New police station with a secure booking area, state-of-the-art evidence processing and storage, and secure front lobby.
- A 4-bed dormitory for EMT personnel.
- Shared community/training room.

Completed July 2024

Project Cost: \$10,500,000

Contact:

Stephanie Skraba

City Administrator

(218) 254-7960

sskraba@ci.chisholm.mn.us

CHISHOLM PUBLIC SAFETY BUILDING

Chisholm, MN

The City of Chisholm, located in the heart of Minnesota's Iron Range, originally hired Wendel to provide an analysis of their existing 100-year-old downtown fire/police station. After the study quickly determined that renovation of the existing facility would not be feasible, our next task was to provide a site location study for a new public safety facility.

The site chosen for the facility on the east side of town will provide optimal response times for police, fire and EMT services. As part of Chisholm's sustainability commitment, the building is designed to meet Minnesota B3 guidelines. Features incorporated into the design include:

- Minimized site disturbance for native plant/animal accommodations
- Stormwater reclamation
- PV solar generation
- EV charging stations
- Daylight harvesting
- Energy recovery units
- Material reduction/reuse
- Envelope optimization
- Low-consumption plumbing fixtures
- Low-emitting finishes



Station Highlights:

- 22,550 sf
- Training Center
- Dormitories with pass-through gear lockers
- Kitchen
- Dining Room
- Day Room

\$5,000,000 (estimate)

\$4,947,311 Cost of Work

New Construction

Spring 2021

Alex Kaker

City Administrator

12781 Velp Avenue

Suamico WI 54313

940.434.2212

villageadministrator@suamico.org

SUAMICO NEW FIRE & EMS STATION

Suamico, WI

Upon completion of an existing facility assessment, the Village of Suamico retained the services of Five Bugles Design/Wendel to design its new 22,550 sf central station.

This two-story station was designed with function and the future in mind. The first floor of the facility features a small administration wing, large training room, apparatus support spaces, personal decon spaces, and a paid-on-call volunteer check-in area. Designed to have four apparatus bays as a base bid, two additional bays we added as an alternate in the bidding process. An additional future garage space was planned to be added to the facility's east side. This future garage would house smaller vehicles, freeing up space in the apparatus bay for larger equipment.

Accessed by the hose training tower, the second floor of the facility is private living quarters for personnel only.

Currently operating as a volunteer department, true living quarters were not needed. However, emergency medical services (EMS) for the Village is provided through Brown County EMS. Working together, it was determined that the second floor of the facility would be built out and rented to Brown County for use by its full-time staff. A mezzanine space was designed to be retrofitted into additional dorm spaces if the Village moves from a volunteer to a career model in the future. Second floor living quarters include dorm rooms, day room, kitchen, dining, and exercise space, which was placed here so that city employees could use it without having access to the rest of the facility or the living quarters.

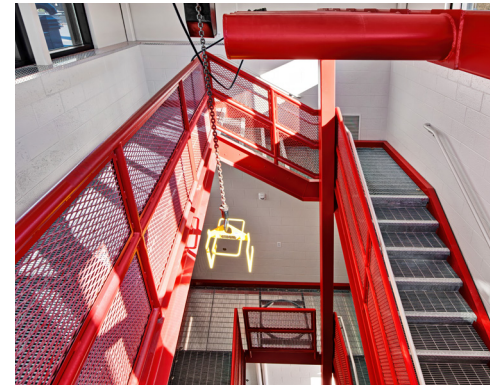

Station Highlights:

- 24,680SF
- Training Center
- Volunteer Station: Fire & EMS
- 6 Drive-through apparatus bays dedicated to Fire
- State-of-the-Art Decontamination zone
- Exercise Room
- Shell-out space for future living quarters

\$6,200,000 (estimate)

\$6,232,485 Cost of Work

New Construction

December 2019

Eric Kitowski

Deputy Chief

W6860 Parkview Drive

Greenville, WI 54942

(608) 358-1942

Ekitowski@townofgreenville.com

GREENVILLE FIRE & SAFETY

Greenville, WI

The Town of Greenville selected the Wendel/Five Bugles Design team to provide a feasibility study and assist in referendum support for replacing their existing central fire station. While working with another architectural firm, the Town experienced a 70/30 failed referendum in 2015. Our team was then hired to reconsider the Town's needs while reducing the size and cost of the proposed station. The result of these reductions and our informational campaign resulted in a successful 58% supported referendum in the Fall of 2018.

Immediately following the successful referendum, the Wendel/Five Bugles Design began design of the new 24,680 S.F. volunteer fire station.

This new facility will include a training room, training tower, administrative offices, exercise room, state-of-the-art decontamination area and six drive-through apparatus bays.

With an eye on the future, the project also includes building out the exterior shell for future living quarters (2,290 sf) to be completed when the need arises. Future living spaces will include six dorm rooms, a day room, kitchen and dining room, until then this shelled out space will serve the department as a training space.



Station Highlights:

- 15,233SF
- Career Satellite Station:
Fire & EMS
- 4 Drive-through apparatus bays
- Training Center
- Training Tower
- State-of-the-Art
Decontamination zone
- Exercise Room
- Dormitories with pass-through gear lockers
- Kitchen
- Dining Room
- Day Room

\$4,600,000

New Construction

Spring 2020

Contact:

**Jeremy Kopp, Fire Chief
(715) 261-7901**

jeremy.kopp@ci.wausau.wi.us

WAUSAU FIRE STATION NO. 2

Wausau, WI

The City of Wausau selected the Wendel/ Five Bugles Design team to design a replacement facility for the existing station no 2 which serves the city's west side. Through GIS study the ideal site location for this new station was located on Highway 52. Due to the predominance of this location, this new station was designed to serve as a gateway into the Downtown.

This satellite station features complete living quarters with 6 dorm rooms, a training room, a training tower, and exercise room, as well as a state-of-the-art decontamination area and four drive-through apparatus bays.

Though public access will be limited to this station, it was designed to have a community zone with access to public toilets and the training room while the rest of the station will remain secure from the public.

Construction began in Summer 2019 with final completion in Spring 2020.



Station Highlights:

- Six Apparatus Bays
- Training Room
- Training Tower
- State-of-the-art Decontamination
- Living Quarters for Five

Cost: \$4,500,000 Cost of Work

Construction Completion: 2021

David Briggs

Fire Chief

Riverside Fire District

211 Grand Ave.

Rothschild, WI 54474

RIVERSIDE FIRE STATION

Schofield, WI



After the consolidation of two fire departments into the Riverside Fire District, it was determined that a new facility should be designed and constructed. Five Bugles Design worked with the design committee to review numerous sites in terms of their constructability and response times. Ultimately, it was determined that the new facility would be constructed on the site of the former Rothschild Fire Station. This challenging site requires the razing of three structures, and the installation of a sheet piling wall to the north of the structure.

This new station features a two-door apparatus bay for the Districts' EMS response vehicles, and a four-door apparatus bay for the Fire response vehicles, with space between them for turn our lockers, storage, SCBA cleaning, and a mezzanine accessible by the training tower on the front of the facility. This tower will serve to dry hoses and will allow training opportunities for this department, while creating a stunning architectural feature on the public side of the facility. Also included in the station is a large community room, offices for the District, living quarters for five, and a state-of-the-art personal decontamination zone.



Station Highlights:

- Six Apparatus Bays
- Training Room
- Exercise Room
- State of the Art Decontamination
- Living Quarters for Eight

\$4,500,000

Construction Completed: 2021

Contact:

Dudley H. Wright, Fire Chief

Station Phone: (740) 967-2976

Cell: (740) 404-3980

firechief@monroetownship.org

MONROE TOWNSHIP FIRE STATION

Johnstown, OH

Located in Johnstown, Ohio, the Township of Monroe hired Five Bugles to design a new Fire/EMS Station, replacing their existing station 501. This six-bay station features state-of-the-art personal decontamination zone, a training room for fifty, administration quarters for the department and the Township, and living quarters for eight.

The front of the facility boasts a striking two-level, tower-like structure, which allows for an interior mechanical room, and mezzanine storage, while providing a break from the surface plane of the front façade.

The locally sourced brick waistcoat is a wonderful example of how to enhance a pre-engineered metal building with texture and add color while maintaining a conscientious budget. Large windows above the glass overhead doors will flood the apparatus bay with natural light.

With design beginning in the summer of 2019, the project went out for bid in the spring of 2020, and is scheduled for substantial completion in February 2021.



Station Highlights:

- 20,000SF
- Central Station
- Career Station: Fire & EMS
- 6 Drive-through apparatus bays
- Training Center
- Training Tower
- Dormitories with pass-through gear lockers
- Kitchen
- Dining Room
- Day Room
- Exercise Room

\$4,000,000 Cost of Work

**New Construction
Completed**

Lee Douglas

Fire Chief

211 Bay Street

Chippewa Falls, WI 54729

715.723.5710

CHIPPEWA FALLS FIRE & EMS STATION

Chippewa Falls, WI

The City of Chippewa Falls selected Five Bugles Design to provide a comprehensive G.I.S. Site Selection Study as well as Architectural Design Services for the City's new Central Fire Station. Located on the City's east side, its location with immediate access to two highways provided the opportunity to adequately serve the growth on the South side of Chippewa, but also reach the industrial park on the City's North side.

This facility is home to the Fire administration, as well as the Fire Secretary and the Fire Inspection Department.

The City's rich history and culture was reflected throughout the facility's architectural design.

Beautiful exposed wood beams in both the entry lobby and the predominate training tower were designed to reflect the Northwoods feel that is so proudly displayed at local businesses.

A large bronze bell is proudly displayed at the front of the station. This bell was forged in 1882 and was used by citizens and firefighters when smoke or fire was detected as an alarm system. The departments crest was also cast into stone medallions and installed into the station's exterior. Finally, a bronze sculpture is showcased in the lobby which symbolizes the front line of action.

The project was completed in April 2017, on time and under budget.



Station Highlights:

- 16,450SF
- Career Station: Fire & EMS
- 5 Drive-through apparatus bays
- Training Center
- State-of-the-art Decontamination zone
- Dormitories with pass-through gear lockers
- Kitchen
- Dining Room
- Day Room
- Shielded Patio
- Exercise Room

\$4,130,000 Cost of Work

New Construction

July 2018

Matthew Jaggard

Fire Chief

216 South Dewey Street

Eau Claire, WI 54701

(715) 839-5012

EAU CLAIRE FIRE STATION NO. 10

Eau Claire, WI

In 2017, the City of Eau Claire selected Five Bugles Design, a division of Wendel, to be the architect on a new satellite station, replacing existing Fire Station No. 10 on the city's East Side. Replacement of Station No. 10 had been determined during a Lifecycle Analysis Study of the existing station, also performed by Five Bugles. This study revealed a myriad of issues; most notable were its location on an extremely busy intersection making it difficult to pull into and out of the drives, its landlocked site making expansion impossible, and both the size and condition of facility itself which no longer met the needs of the department.

Special consideration in this project was taken with the location of and preparation of the selected site. As with nearly all fire stations designed by Five Bugles, our team performed a comprehensive GIS study to determine which site would serve the City and the Department the best. The site, which was selected based on its location, accessibility, and availability, was a densely vegetated site that due to a ravine had been used by locals as a waste disposal area in the early 1900's.

Geo-technical data indicated that approximately half of the proposed facility could be placed in the northwest quadrant of the property which was comprised of virgin soils, while the other half would be placed over the former waste land. In order to prepare the waste land to receive this new facility, the ground was excavated to depths of 30' to remove materials, and a Phase 2 Environmental Site Assessment was completed indicating the need for a passive vapor system to be installed under the building slab.

Services provide by Wendel and Five Bugles Design included architectural design, GIS, and a Life Analysis Study. This project was bid in the late summer of 2017, construction began shortly afterwards, and the station opened in July of 2018.



Station Highlights:

- 33,000 SF
- Central Station
- Career Station: Fire & EMS
- 8 Drive-through apparatus bays
- Training Center
- Dormitories with pass-through gear lockers
- Kitchen
- Dining Room
- Day Room
- Shielded Patio
- Exercise Room
- Station Alerting System

\$6,000,000 Cost of Work

New Construction Completed

James Ponkauskas
Deputy Fire Chief
303 Milton Avenue
Janesville, WI 53545
608.373.3433
ponkauskasj@ci.janesville.wi.us

JANESVILLE FIRE & EMS STATION

Janesville, WI

The City of Janesville hired Five Bugles Design to replace its aging Central Fire Station. While the location of the existing station on Milton Avenue was determined by GIS study to be the most desirable location, the site was too small. The size of the site and how to continue operation of the existing station during construction became the projects primary consideration.

Through extensive planning, it was determined that in order to position the new facility in this location, the City needed to purchase several adjacent properties and remove the residential homes upon them as well as vacate a small street on the northwest side of the property.

By razing these facilities, the new station was able to be placed to the north of the existing facility, which allowed the continued 24/7 operations throughout construction.

The new 33,000 sf station reflects the original station in its architectural styling, further reflected by the reuse of a fire pole from the original station.

This station bid early in 2015 and opened to the public April 1, 2016. Though this project had its challenges, the end result beautified the intersection of Milton and Centerway, allowing it to truly become the Gateway to Janesville's Downtown.



Station Highlights:

- 44,000SF
- Career Station: Fire & Private EMS
- 6 Drive-through apparatus bays dedicated to Fire
- 2 ambulance bays
- Training Center
- Public Museum
- Decontamination zone
- Dormitories with pass-through gear lockers
- Kitchen
- Dining Room
- Day Room
- Exercise Room

\$9,180,000 Cost of Work

New Construction

July 2015

Bill Burns

**Verona City Administrator (former)
City of Middleton
7426 Hubbard Ave. Middleton, WI
53562 bburns@ci.middleton.wi.us
608.821.8356**

VERONA FIRE & EMS STATION

Verona, WI

Following a study of their existing facility and with consideration to their rapidly growing community, it was determined that the City of Verona needed to replace their existing fire station. The new facility would allow their volunteer station to become a career station with additional paid-on-call staff. This station also has the unique partnership with the Fitch-Rona EMS; a private paramedic EMS program that serves both the Verona and the nearby Fitchburg area with ALS delivery services.

During the study, it was determined that the existing location was ideal for the new station. However, the existing station needed to remain in use during construction and still allow the best orientation for the new station to serve the community in the future.

The new station was placed to allow the apparatus bays in the existing station to re-main in use until the new station was complete, while the administration offices were relocated to trailers on site, allowing for continued 24/7 response throughout construction.

The architectural design was the result of numerous public presentations and open house forums throughout the design process. Community leaders stated that they wanted this new station to be, "...the standard of construction that we wish to see as the community grows."

This project was bid in April of 2013 and opened to the public July 1, 2015.



Project Highlights:

- Architectural Design
- Master Planning
- Interior Design

Completed

\$8.7 Million Cost of Work

Contact:

Todd Prafke

City Administrator

(507) 934-0663

toddp@saintpertermn.gov

ST. PETER FIRE STATION

St. Peter, MN

The City of St Peter, MN hired Five Bugles Design to design a new state of the art fire station in St. Peter, MN. This 23,100 square foot facility will be funded using USDA borrowing and paid for through a community referendum supporting a .5% sales tax. The facility was designed with five bays in the base bid and a sixth bay as an alternate. Other various alternates are included in the design such as ice-melt on the apparatus bay aprons, concrete in lieu of asphalt aprons, fluid applied flooring in the apparatus bays and four-fold doors in lieu of standard overhead doors.

The department is a volunteer department and took on the process of decontamination by designing those features into their new facility.

This includes PPE storage, gear laundry, decontamination hallways and decontamination toilet/showers with steam capabilities. Training within the station was a requirement of the department and a Training Tower sits proudly between all the apparatus bays on the front elevation as well as a training room within the administrative areas.

The training room can accommodate up to 50 personnel sitting at tables and chairs as well as a kitchen that is large enough to support various community events. The remaining rooms in the facility include various offices for ranked department members, a conference room, maintenance offices and a staging area.

The facility bid in June 2022 with construction beginning that summer and completion occurring in the fall of 2023.



Station Highlights:

- 37,000 Square Feet
- Training Center
- Living Quarters
- EMS
- LEED Gold

\$4,800,000 Cost of Work

New Construction

Completed - Spring 2010

Scott Owen, Fire Chief
City of Marshfield Fire Department
412 East Fourth Street
Marshfield, WI 54449
715.486.2090

MARSHFIELD FIRE & EMS STATION

Marshfield, WI

Steve Gausman and Robert Krzyzanowski assisted the Marshfield Building Committee in reviewing fifteen various sites within the stipulated geographical area. Space Programming sessions were conducted with the Building Committee over multiple dates. As a result of this study, Marshfield Fire and Rescue decided to move ahead with a 37,000+ SF facility, completed on schedule and under budget. The proposed design was constructed as an urban infill project on a downtown site that accommodates several sustainable features. The City of Marshfield is a leading proponent of sustainability and achieved a LEED Gold certification for this facility.

The Architectural Design was the result of numerous public presentations and open house forums during both programming and schematic design phases of the project.

Additionally, the building's design further resulted from meetings with the local Historical Society to incorporate design elements of past Marshfield buildings. Public Relations techniques included interviews on Public Radio.



Station Highlights:

- 21,240SF
- Career Station: Fire & EMS
- 1 Drive-through Fire Apparatus Bay
- 3 Fire Apparatus Bays
- 4 EMS Apparatus Bays
- Training Center
- Training Tower
- Exercise room
- 8 dormitories
- Kitchen
- Dining Room

\$3,800,000 Cost of Work

New Construction

2016

David Wegener, Fire Chief
Ashland Fire Department 300
Stuntz Ave
Ashland, WI 54806
715.682.7052
dwegener@coawi.org

ASHLAND FIRE & EMS STATION

Ashland, WI

After working with Five Bugles Design for over 12 years on multiple studies, the City of Ashland passed a resolution to design and build a new central fire station.

Located on the Chequamegon Bay of Lake Superior, the Ashland Fire Department serves Ashland, as well as numerous other surrounding areas to which they provide mutual aid. This location also requires high levels of specialty training including hazmat and ice rescue. Because of this, a large emphasis was placed on the design to incorporate a training room, exercise room, training tower and a mezzanine space that can be used for training purposes.

The site selected for the new station, though ideal for response times, limited the size and configuration of the station. Due to these restrictions, only one apparatus bay was created as a drive through. With the other seven bays as single access bays, the workshop, compressor, a decon toilet room, decon laundry room, and gear turnout were all able to be placed along the back wall of the bays.

Bidding for this project was in the Spring of 2015 with final completion and Owner occupancy the following year.



Station Highlights:

Public Private Partnership
Multi-use facility with Fire Station headquarters
Three story fire station
Redeveloped Site

New Construction

Construction in Spring 2026

\$19 million Construction Cost

Contact:

Matthew Knott, MS, EFO, CFO
Fire Chief
Green Bay Metro Fire Department
(920) 448-3278 Office
M: (920) 615-8958 Mobile
Matthew.Knott@greenbaywi.gov
govgreenbaywi.gov/fire

GREENBAY FIRE/EMS STATION

Green Bay, WI

The condition of the existing infrastructure for the Green Bay Fire Department Headquarters facility was visibly in dire need of addressing. The department hired Five Bugles Design to review the conditions of Station 1 formally as well as Station 3, do a GIS analysis of their department to determine where their stations ought to be located for best coverage, and to create concept plans for a large, combined single replacement facility. During this study, a catastrophic event happened, forcing the department to relocate their administration immediately. Replacement moved from a future goal to an immediate need.

Several locations for a replacement station were considered. The site needed to be large enough to house this large station, to be near downtown for both coverage needs and for best practice as their headquarters facility, and there was a desire to have a training facility, including a live-fire burn tower on-site.

With property owned by Green Bay's Redevelopment Authority, an idea of a combination mixed use facility, fire station headquarters and public-private partnership came into reality. Five Bugles Design was brought on with partners General Capital Group and Engberg Anderson to conceptually plan this project on the old Badger Manufacturing site located on S. Broadway Street, one block from the Fox river, and along an abandoned railroad line. Badger Manufacturing vacated this property several years ago, after an on-site fire, and was willing to sell the property to the city for this PPP project.

The PPP project will include razing the entire manufacturing facility, remediating the soils after PFOS contamination, and constructing a five-story mixed use facility and a three-story headquarters station for the Green Bay Fire Department.

The fire department, in order to fit onto the property, is designed with fire apparatus, apparatus support, personal decontamination, and a watch office on the first floor of the building. The second floor will house the living quarters for the station, including twelve dorms, four single-user all-gender toilet/shower rooms, a large exercise room, and their kitchen, dining, and day rooms. The third floor of the station will extend over all the apparatus bays. This level will house the department's administration as well as a large training room.

Careful consideration for departmental relationships, function, and most importantly, response times, were taken throughout the design of this facility. This was especially important with such a limited site, and so much program needing to be addressed.

A connected atrium will bridge the gap between the fire station and the mixed-use facility. This atrium will boast images and artifacts of the department's history, allowing all visitors to view when they come to the station.

The design of the station is underway, with construction expected to begin on the mixed-use side of the facility in the late fall of 2025, and the fire side of the facility in late spring 2026.



Conceptual Imagine courtesy of Engberg Anderson

Station Highlights:

- 48,000 sf central station
- Dedicated & Flexible Emergency Operations Center (EOC)
- Satellite Station with most of the same features as Station 1

Station #1: \$15,200,000 (estimate)

Station #2: \$5,700,000 (estimate)

New Construction

Bidding Fall 2025

Contact:

Kevin G. Stieve

Fire/EMS Chief

Baraboo Area Fire & EMS District

City of Baraboo Emergency

Management Director

(608) 356-3455

kstieve@baraboofireandems.com

CITY OF BARABOO FIRE/EMS STATION

Baraboo, WI

Five Bugles Design provided design and construction services for the City of Baraboo's new fire station. During early programming and facility tours, it was determined that with the city's current needs and anticipated growth, the department would need a satellite station in the immediate future. This realization led to the project scope expanding to include the concurrent design of one large, central station, and a smaller satellite station.

The 48,000sf Central Station will serve as the department's headquarters, and primary training facility. Three primary factors influenced the layout of this facility: response times, particularly with such a large facility; the desire to separate day-to-day operations; and the quantity of apparatus and support vehicles. All three of these factors drove the resulting design, in addition to the standard concerns of safety and civilian / department interaction.

Features of the station include the departments administration, dedicated and flexible Emergency Operations Center (EOC), extensive training facilities, exercise space, a mental health room, personal decontamination, and living quarters for ten.

The smaller satellite station provides most of the same features as Station 1, at a smaller scale. This includes office space, a watch room, three drive-through apparatus bays, personal decontamination spaces, exercise room, training facilities, and living quarters for six.

The project is set to bid in Fall 2025, with completion of both facilities in the Fall of 2026.



Station Highlights:

- 31,000 SF
- Volunteer Department, planning for future career staff

New Construction

Estimated cost of work: \$12.5M

Estimated total project cost: \$14M

Anticipated Opening: 2026

Contact:

Ryan Simmons Fire Chief
City of Platteville
275 E. Main St.
Platteville, WI 53818
608-348-7826
firechief@platteville.org

PLATTEVILLE FIRE DEPARTMENT

Platteville, WI

The Platteville Fire Department is a volunteer department, located in the southwest corner of Wisconsin. In the winter of 2020, Five Bugles Design was brought on board to conduct a study of their existing 1960's facility. After consideration of the two-story facility, with incredibly low floor-to-floor heights, and an extremely landlocked site, it was determined that a new facility should be designed and constructed to replace the existing station.

The new station will be a new construction, single-story facility, with a mezzanine, and will be located on the site of the former EO Gray Learning Center. The station's seven apparatus bays will be prominently located on the intersection of US Highway 51/W. Adams Street, and N. Chestnut, which is a major path of travel out of Platteville to the north.

Upon entering the station, visitors will enter a large lobby with historic displays. This lobby will then allow access to a large training room, public toilet rooms, and the district's administration. The training room will allow for seating for 60 in tables and chairs, will have a dedicated kitchen, and will have storage spaces.

The administration zone will be comprised of an open office, a work room, three private offices, and a conference room, which will have access to the lobby. Located directly off the administrative spaces will be the command garage, which will house the department's smaller vehicles.

Located just off the public zone, the core of the facility will house the staff support spaces, such as the watch room, workshop, self-contained breathing apparatus (SCBA) clean and fill station, gear lockers, gear laundry and decontamination all-gender toilet/showers. These spaces will have direct access to the apparatus bay, which will have seven drive-through bays.

Though the department is currently volunteer based, the administration is looking out for their volunteers, as well as looking to the future needs of the department. Because of this, seven single-user dorm rooms will be constructed, as well as two all-gender single-user toilet rooms, a kitchen, dining room, and day room. Until the department becomes full time, the dorms could be used by local university students who serve the department, or by other volunteers during anticipated weather events.

With design of this facility underway, the project is slated to break ground in the spring of 2025, with occupancy in the spring of 2026.





03

Key Individuals, Qualifications & Experience



TEAM OVERVIEW

Wendel's emergency services team has years of experience working together on similar public safety buildings projects. On the following pages we have included the resumes of our team members that will serve you on this project. We pride ourselves in the quality of service and the level of attention we provide to each of our clients. These team members were selected based on a balance of talent, experience, and their availability to provide the City of Eau Claire best experience possible.

VILLAGE OF GERMANTOWN, WI FIRE STATION #2



**Five Bugles
Design**



**Mitchell Associates
Architects**

Wendel's award winning public safety design team

ROBERT KRZYZANOWSKI
Director of Emergency Services
Principal-in-Charge/Project Manager



**Five Bugles
Design**



**Mitchell Associates
Architects**

Wendel's award winning public safety design team



Robert Krzyzanowski



Director of Emergency Services/Principal in Charge

As the Director of Emergency Services for Wendel, home of the award-winning Five Bugles Design and Mitchell Associates Architects, Robert oversees the entire emergency services team and its portfolio for all Wendel offices across the country. He has over 25 years of experience working on public projects and has been involved in over 60 emergency services projects in the past four years, and over 100 during his career. Having been one of the founding members of the Five Bugles Design brand over 15 years ago, he understands the niche of emergency services design and works within that portfolio full time.

He understands that the team's next project relies not only on the success of the entire portfolio, but every single project. He takes pride in pushing his team to do right by the client, to be efficient and to design projects to their overall final environment that clients can be proud and comfortable in. His vast array of experience allows him to assist owners in designing and constructing buildings that meet their specific space needs, functionality, and building type requirements.

Robert can wear many hats on any project that Wendel is involved in, but also serves on Wendel's leadership team, having been involved with annual business planning, strategic planning, and the acquisition team. As a Senior Associate Principal, Robert serves as a leader in business development, team management, and overall project management

Associate Principal

Education

Associate's Degree, Drafting and Design Technology, Winona Technical College
Winona, Minnesota (1998)

Continuing Education

Project Management Bootcamp
PSMJ Resources, Inc.
Presented by Alan Bollinger
St. Paul, Minnesota

LEED for New Construction
Como Park Zoo and Conservatory
Saint Paul, Minnesota

Awards

Chippewa Falls Fire Station
2018 Firehouse Station Design Award

Eau Claire Fire Station
2018 Firehouse Station Design Award

2017 Station Design Judge
Firehouse Magazine
Station Design Awards

Verona Fire and EMS
2016 Firehouse Station Design
Shared Facilities Notable

Contact Information:

204 E. Grand Avenue, Suite 200
Eau Claire, WI 54701
p. 715.832.4848
rkrzyzanowski@wendelcompanies.com

Fire/EMS Design Experience

- | | |
|-------------------------------------|--------------------------|
| Ashland, Wisconsin | Lehi, Utah |
| Bellevue, Wisconsin | Lewiston, Minnesota |
| Bloomington, Illinois | Marathon City, Wisconsin |
| Bloomington, Minnesota | Marshfield, Wisconsin |
| Chippewa Falls, Wisconsin | Middleton, Wisconsin |
| Chisago City, Minnesota | Milton, Wisconsin |
| Chisholm, Minnesota | Monroe, Ohio |
| Cloquet, Minnesota | Mount Horeb, Wisconsin |
| Cold Springs, Minnesota | Normal, Illinois |
| Eau Claire, Wisconsin | Red Wing, Minnesota |
| Elkhart Lake, Wisconsin | Rib Mountain, Wisconsin |
| Farmington, New York | River Falls, Wisconsin |
| Fitchburg, Wisconsin | Stewartville, Minnesota |
| Greenville, WI Fire Department | Stoughton, Wisconsin |
| Inver Grove Heights Fire Department | Suamico, Wisconsin |
| Janesville, Wisconsin | Superior, Wisconsin |
| Jefferson, Wisconsin | Verona, Wisconsin |
| Kenosha, Wisconsin | Wausau, Wisconsin |
| La Crosse, Wisconsin | |
| Ladysmith, Wisconsin | |



Laura Eysnogle, AIA, CID, WRID



Architect/Interior Designer

Laura joined the Wendel team with 15 years of experience in public sector interior design, space planning, and architectural design. She works with clients from project conception through the ribbon cutting phases balancing the importance of efficiency and durability with adaptability and aesthetics. With a background in all community and public sector projects, Laura understands the need for spaces to perform in their most efficient manner and to be a good steward of the tax payer's dollar yet still provide the community with a facility that they can be proud of. Laura feels that the most rewarding part of her job is listening to clients, working to successful solutions, and finally watching as the community embraces their new facility. Laura's experience includes a variety of projects from a new 14,000 sf Laramie #3 Fire Station to a 65,300 sf renovation / 67,650 sf addition to a high school to strategic planning for the 1.6 million assignable square feet for a major research university. Her experience in new construction, renovations and strategic planning has allowed her the opportunity to consider projects from every aspect. What was the project yesterday, what is it today, and what will it be tomorrow.

Licenses & Certifications

Registered Architect, WI
Registered Interior Designer, WI
Certified Interior Designer

Education

University of Wisconsin-Stout,
Bachelor of Fine Arts: Interior Design

Affiliations

Eau Claire Chamber of Commerce -
Leadership Eau Claire, Class of 2019

Girls on the Run Assistant Coach,
Spring 2019

Active member of the Young
Professionals of the Chippewa Valley

Years of Experience

19 years

Contact Information:

204 E. Grand Avenue, Suite 200
Eau Claire, WI 54701
(715) 832-4848
leysnogle@wendelcompanies.com

Project Experience

- Cold Spring Public Safety Building, Cold Spring, MN
- Town of La Pointe Emergency Services Building, WI
- Monroe Township Fire Station, OH
- Suamico Fire Station, WI
- Chisholm Emergency Services Building, MN
- La Crosse Fire Department, WI
- Wisconsin Rapids Fire Department, WI
- City of Laramie, Fire Station #3 (New Building), Laramie, WY
- City of Cheyenne, Board of Public Utilities New Office Building, Cheyenne, WY
- City of Eau Claire, South Entry Replacement, Eau Claire, WI
- City of Laramie, Fire Station #3, New Building, Laramie, WY
- City of Cheyenne, Board of Public Utilities New Office Building, Cheyenne, WY
- Lake Dillion Fire & Rescue, New Public Works Facility, New Fire Station Study & Conceptual Design, Lake Dillion, CO
- Cottage Police Public Works & Parks & Recreation Facility Remodeling, Furniture Selection & Procurement Assistance, Cottage Grove, WI
- City of Eau Claire, South Entry Replacement, Eau Claire, WI
- Plate Valley Fire Protection District, New Fire Station Study & Conceptual Design, Kersey, CO
- School District of Ashland, High School Addition & Remodeling, Middle School Addition & Remodeling, Furniture Selection & Procurement Assistance, Ashland, WI
- School District of Bloomer, Referendum Assistance, Middle School Addition & Remodeling, Bloomer, WI
- School District of Cashton, Middle/High School Addition & Remodeling, Elementary School Addition & Remodeling, Furniture Selection & Procurement Assistance, Cashton, WI

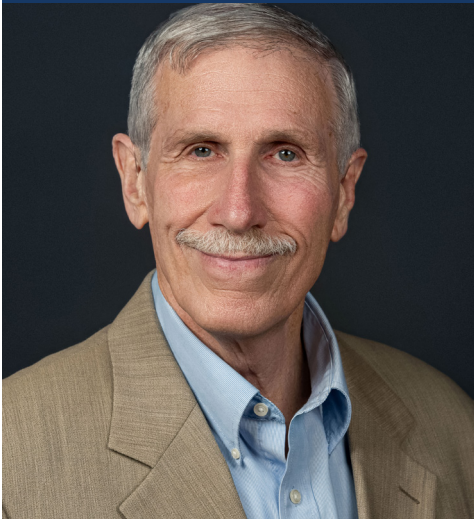

Robert Mitchell, AIA, NCARB

Architect

Bob's work is focused exclusively on emergency services facilities. This focus is supported by a depth of experience gained in over 28 years in design, construction, evaluation, and renovation of fire stations, with over 189 projects involving more than 326 emergency services facilities throughout the northeast, eastern seaboard, Missouri, and Alaska. He has provided programming for more than 170 fire station and emergency services facilities and has completed more than 60 feasibility studies to evaluate the option of renovating/designing additional space versus building new. Bob presents at national conferences and is author of the chapter on fire station renovation and additions for the Fire Station Design Handbook published by the International Association of Fire Chiefs Foundation. His work is featured in FEMA's fire station design manual.

Licenses

Registered Architect: NCARB,
Connecticut, MD, MA, NJ, NH,
NY, PA, VT, VA

Education

Bachelor of Science in Building
Science,
Rensselaer Polytechnic
Institute, 1968

Expertise

Firematic Design
Project Management
Cost Estimating
Public Support
Energy-Efficient Building
Design

Affiliations

American Institute of
Architects, International
Association of Fire
Chiefs, NFPA, NYSAFC

Years of Experience

30 Architecture
40+ Building, Solar &
Energy Expertise

Project Experience

Beacon (NY) Fire Depart/City Hall
Beukendaal (NY) Fire District
Carver (MA) Fire Department
Cortland (NY) Fire Department
East Putnam (CT) Fire Department
King of Prussia (PA)
Lancaster (PA) Fire Department

Long Hill (CT) Fire District
Midway (NY) Fire District
Newburgh (NY) Master Plan Study
N. Castle Fire (NY) District #2 Armonk
Peekskill (NY) Fire Department
Philadelphia (PA) Fire Department

Awards And Recognition (Since 2003)

2021 Firehouse Station Design Award Notable Design, Purchase, NY Fire Station
2020 Firehouse Station Design Award Notable Design, Long Hill, CT Fire Station
2019 Firehouse Station Design Award Gold, Peekskill NY Fire Headquarters
2018 Firehouse Station Design Notable Design Award, Schoharie, NY Fire Station
2018 Firehouse Station Design Notable Design Award, South River, NJ Fire
2017 Firehouse Station Design Gold Award. Town of Carver, MA Fire HQ (3)
2016 Firehouse Station Design Bronze Award, Town of Glenville, NY Fire Station
2015 Firehouse Station Design Notable Design Award, East Putnam, CT
2014 Station Design Recognition Award, F.I.E.R.O., Valley Forge, PA Fire Station
2013 Firehouse Station Design Notable Design Award, Slingerlands, NY
2012 Station Style Notable Design Award, Fire Chief Magazine; Rensselaer, NY
2011 Station Style Bronze Award, Fire Chief Mag: Holden, MA Safety Facility (3)
2010 Station Style Notable Design Award, Fire Chief Mag: Briarcliff Manor, NY
2009 Station Style Notable Design Award, Fire Chief Magazine; Philipstown, NY
2008 Station Style Notable Design Award, Fire Chief Mag; Skaneateles, NY (1)
2007 Station Style Notable Design Award, Fire Chief Mag; Chestertown, NY (2)
2006 Station Style Gold Award, Fire Chief Magazine; Hudson, NY Fire Station (2)
2005 Station Style Gold Award, Fire Chief Magazine; Armonk, NY Fire Station (2)
2004 Station Style Notable Design Award, Fire Chief Magazine; Herman, PA
2003 Station Style Gold Award, Fire Chief Magazine; Cayuga Heights, NY (2)



James Schmidt



Emergency Services Specialist

James Schmidt's career began in 1979 as a Fox Valley Technical College (FVTC) cadet firefighter at the Town of Grand Chute and Oshkosh Fire Departments. In 1982, Jim was hired by the City of Marshfield Fire and Rescue Department as a Firefighter/Emergency Medical Technician. He worked his way up the ranks and as a Deputy Fire Chief responsible for a number of programs and duties including emergency response and management of career Fire/EMS personnel, coordination of the Fire Investigation Program, Special Operations Training/Response (Hazardous Materials, Elevated Rescue, Confined Space Rescue, Trench Rescue), and the development of a Regional Training Center.

In 2007, Jim was promoted to Fire Chief and is most proud of the relatively small part he played in changing the culture of the department. In addition, under Jim's direction, the department was able to add staff and build Wisconsin's first Gold LEED Central Fire Station in Marshfield. Shortly after completing the National Fire Academy's Executive Fire Officer (EFO) program, Jim was able to continue moving the department forward by reducing the city's Insurance Services Office (ISO) rating and embracing many state and federal grant opportunities to help off-set the costs of new Personal Protective Equipment (PPE), a Medium Duty Rescue Truck, Self contained Breathing Apparatus (SCBA's), and SCBA Air Compressor.

In 2013, Jim retired as the Fire Chief of the City of Marshfield but has remained active in the fire service. Jim joined the Town of Rock Volunteer Fire Department as a Safety Officer/First Responder and authored the department's Standard Operating Guidelines, became a State Representative for the Wisconsin Technical College Fire Service Training section, accepted an interim Fire Chief position with the Rothschild (Combination) Fire Department (2015), Interim Fire Chief with the Town of Rome (Volunteer) Fire Department (2016). In addition, Jim started a consultant business specializing in assisting communities in the fire chief hiring process, mentoring new fire chiefs and upper level managers, and the consolidation of fire departments.

Project Experience

- Wausau, WI – Fire Station Design, Police Station Remodel
- Chisholm, MN – Fire Station Design, City Hall Design, Joint Training Facility Design
- Bloomington, MN – Fire Station Designs (Five)
- Greenville, WI – Fire Station Design & Referendum Assistance
- St. Peters, MN – Fire Station Design
- Town of Superior, WI – Fire Station Design
- River Falls, WI – Fire Station & EMS Station Design
- Williams Bay, WI – Fire Station Design
- Elk River, MN – Fire Station Designs (Three), Police Station Remodel, Joint Training Facility Design

Licenses & Certifications

- Executive Fire Officer
- Emergency Medical Technician
- Wisconsin State Fire Inspector
- Hazardous Material Response Technician
- Wisconsin Fire Service Instructor I

Education

- Associate Degree
- Fire Science Technology
- Fox Valley Technical College
- Appleton, WI

- Business Administration
- Lakeland College
- Plymouth, WI

- Executive Fire Officer (EFO)
- Program Graduate
- Emmitsburg, MD

Professional Associations

- (Past and Present)
- International Association of Fire Chiefs
- National Fire Protection Association
- Wisconsin State Fire Chiefs Association
- North Central Fire Chiefs Association
- International Association of Arson Investigators
- Wisconsin Association of Hazardous Materials Responders
- Wisconsin Emergency Medical Technician Association
- Wisconsin Technical College System
- Fire Service Advisory Board on Education and Training - Co-Chair

Years of Experience
46 years



Kimberly Grabinski

Architect

Kim is a licensed architect in five states with 18 years in the industry. She has worked on a range of projects including light industrial, commercial, municipal, and educational facilities. Her prior experience includes managing the design department for small design-build industrial projects and working as a staff architect for educational and maintenance facilities.

Project Experience

Beaver Dam Fire & Rescue Department, Beaver Dam, WI

Fond du Lac Fire Rescue, , Fond du Lac, WI

Green Bay, Fire/EMS Station, Green Bay, WI

Monroe-Lakeside Fire and Rescue Company, Lakeside Fire & Rescue, Edgerton, WI

Town of Milton, Town Hall/Police Facility, Milton, WI

Platteville Fire Department, Station 1, Platteville, WI

Oregon Area Fire EMS Space Needs Analysis, Oregon, WI

Union Grove-Yorkville Fire Department, Station 1, Union Grove, WI

Wausau Fire Department, Station 1 Feasibility Study, Wausau, WI

City of Knoxville, IA Public Safety, Knoxville, IA

Licenses & Certifications

Registered Architect: WI, IA, IL, MI, MN

Education

BArch, Architecture, University of Illinois at Chicago

Years of Experience

16 years



Years of Experience
35 years

Steve Genz, AIA

Architect

Steve Genz, AIA, is a Senior Architect with over two decades of experience leading complex projects for municipal and government agencies. His expertise spans all phases of design and construction, with a proven track record in delivering functional, sustainable, and community-focused public facilities. He brings deep knowledge of regulatory standards, stakeholder coordination, and cost-effective project management to every engagement.

Project Experience

Lakeside Fire & Rescue, Lakeside Fire Station, Edgerton, WI
Union Grove-Yorkville Fire Department Union Grove, WI

Work done at previous firms

Beaver Dam Police Department and Municipal Court
Page County Sheriff Department and Jail, Clarinda IA
Wood County Law Enforcement Center, Wisconsin Rapids, WI
Marinette County, Renovation of Law Enforcement Center, Marinette, WI
Brown County, Community Treatment Center, Green Bay, WI
Dallas County Law Enforcement Center, Adel, IA

James Winde Jr., PE, LEED AP

Senior Mechanical Engineering

Jim has decades of engineering, technical leadership, and project management experience. His multi-discipline project experience includes an in-depth, creative, and budget conscience approach to facility renovations, upgrades and energy improvements. He also has heating, ventilating and air conditioning (HVAC) systems expertise for new and existing buildings. Jim has successfully completed well over 100 renovation and facility improvement projects ranging from \$50,000 to \$60 million. Jim has received the 2006 and 2016 ACEC Gold Award for Engineering Excellence.

Project Experience

Derry Fire Department, Central Station Headquarters, Derry, NH
City of Niagara Falls, Highland Ave Fire Station, Niagara Falls, NY
Ithaca Fire Department, Station 2, Ithaca, NY
Town of Greenville, Greenville Fire & EMS Station, Greenville, WI
La Pointe Fire Station, La Point, WI
Chisholm Fire Station, Chisholm, MN
South Line Fire Training Facility, Cheektowaga, NY
Orleans County, Public Safety Building, Albion, NY
VA WNY Health Care System, Mental Health Unit Renovation Ward 10A, Buffalo, NY
VA WNY Health Care System, 13th Floor Heating Modifications and Abatement, Buffalo, NY
VA WNY Health Care System, PET/CT Suite Renovation, Buffalo, NY

Principal

Licenses & Certifications

Professional Engineer: AZ, CT, FL, MA,
MT, NH, NY, OH, PA, TX, WV

LEED Accredited Professional

Education

BS, Architectural Engineering
Technology, Vermont Technical
College

AAS, Architectural Engineering
Technology, Alfred State College

Years of Experience

30 years

Affiliations

American Society of Heating,
Refrigeration, and Air Conditioning
Engineers (ASHRAE)

National Fire Protection Association
(NFPA)

National Council of Examiners for
Engineering and Surveying (NCEES)
Membership

Additional Training

ANGI CNG Fuel Station Training

NGVi CNG Fuel Station Operation
and Maintenance Training

NGVi CNG Fueling Station Design
Training

Ruslan Belous



Senior Associate Principal

Education

BT, Electrical Engineering, State
University of New York at Buffalo

Years of Experience

20 years

Additional Training

AGi32 Roadway Lighting Design and
Analysis Training

Electrical Engineering

Ruslan has over a decade of experience in electrical design which includes lighting, power, fire alarms and systems for new and existing buildings. He has worked on numerous school renovation projects, new building utilities, primary and secondary power distribution, and emergency generator installations both for private and public installations.

Project Experience

City of Baraboo, Fire/ EMS Station, Baraboo, WI

City of Cold Spring, Public Safety Building, Cold Springs, MN

Town of La Pointe, Fire Station, La Pointe, WI

Westport Public Safety Facility Study, Westport, CT

Ithaca Fire Department, Ithaca, NY

Doyle Fire District, Cheektowaga, NY

Cambria Volunteer Fire Company, Cambria, NY.

North Bailey Volunteer Fire Company, Amherst, NY

Farmington Volunteer Fire Association, Farmington, NY

Chisholm Fire Station, Chisholm, MN

Platteville Fire Station, Platteville, WI

Noroton Heights Fire Station, Darien, CT

Cortland Fire Station Cortland, NY

Monroe-Lakeside Fire and Rescue Company, Lakeside Fire & Rescue, Edgerton, WI:

Orleans County, Public Safety Building (PSB), Albion, NY

La Crosse Station No. 2, Design & Replacement, La Crosse, WI

Town of La Pointe, Fire Station, La Pointe, WI

Creedmoor Volunteer Fire Department, Station 1, Creedmore, NC



04

Key Subconsultants, Experience & Responsibilities



Quality You Can Count On

Expert Structural, Civil and Forensic Engineering Services

Northland Consulting Engineers (NCE) has been providing professional structural, civil and forensic engineering services in the Upper Midwest for more than 27 years. Our industry experience, combined with our deep commitment to quality service, delivers efficient and cost-feasible results.

NCE is a great team member for your project. We have extensive experience Assessing existing building conditions and site Infrastructure conditions, Assisting with Planning your project, Structural and Civil Engineering Design Services for all types of structures including Historic Structures such as this one. We also have specific knowledge of this structure and the adjacent structures that will help progress the project efficiently.

At NCE, we offer the following professional engineering services for your project:

NCE's complementary offerings of structural, civil, and forensic engineering result in greater efficiency and streamlined process.

Our teams coordinate with each other, saving you time and money throughout your project.

About NCE

- Established in 1997
- Located in Duluth, MN
- Privately Owned LLP
- Staffing
 - Professional Engineer Partners [5]
 - Professional Engineer Staff [5]
 - Engineer In Training [2]
 - Engineer Technician [7]
 - Support Staff [1]
- Staffing by disciplines
 - Structural Registered PE / SE [6]
 - Civil Registered Engineers [4]

Who we work with:

- Architects
- Contractors
- Property Owners
- Insurance Companies/Adjusters
- Attorneys
- Public Sector Clients
- Industrial Clients
- Business Owners

Structural Engineering

The structural engineering team at NCE provides high-quality structural design, analysis, modeling and drafting services to clients across the region. T

- Building Design
- Restoration / Adaptive Reuse
- Condition Assessment
- Specialty Engineering Services
- Industrial Structures
- LEED / Sustainable Design
- Building Expansions
- Historic Preservation / repair
- Consulting / Peer Review
- Parking Structure Certification/Repair
- Bridges

Civil Engineering

Committed to the client's vision, our civil engineering team gains a comprehensive understanding of each project. This includes evaluating competing project interests, maintaining a continuous line of communication with the owner, and developing designs that match the owner's budget.

- Municipal Engineering
- Site Planning and Land Development
- Project Permitting
- Project Cost Estimating
- Construction Contract Administration
- Project Permitting
- Storm Water Management
- Utility Coordination
- Utility Design

Forensic Structural Engineering

We also offer forensic engineering services, including historic preservation, condition assessment, and parking structure certification and repair.

- Investigation
- Condition Reviews
- Report Preparation
- Documentation
- Consulting



“Building long-term relationships and trust with clients is rewarding. We are focused on striving to develop the right solution for each project.”

Professional Affiliations

- Engineers Without Borders
- Timber Framers Guild
- American Wood Council
- American Institute of Steel Construction

Professional Practice

- Clark Johnson Engineers (Bellevue, WA) 1995-1999
- Magnusson Klemencic Associates (Seattle, WA) 1999-2009
- Northland Consulting Engineers LLP 2009-Present

Professional Registrations

Minnesota, Wisconsin, Illinois, Nebraska, New Hampshire, Washington, Wyoming, Georgia, Arizona, Ohio, Virginia, North Carolina

Education

University of Washington, Bachelor of Science, Civil Engineering, 1995

Tom Rines, PE, SE

Principal, Structural Engineer

Tom has over 29 years of structural engineering experience designing a wide variety of structures as well as 8 years of carpentry experience. Originally from Minnesota, he began his professional career in Seattle where he worked on a wide range of projects throughout the West Coast and Mountain States region. Since joining Northland Consulting Engineers (NCE) in 2009, he has strengthened the firm by integrating innovative and thoughtful ideas into our workflow and design processes. Tom became a partner at NCE in 2011 and he is known for a pragmatic and creative approach to design, asking hard questions and generating thought-provoking discussions. Tom’s vast engineering and construction experience is highly valued by his clients and team members.

Tom is proud to be a part of Northland Consulting Engineers where we pride ourselves on the long-term relationships we have formed with our clients. We believe that our high level of service sets us apart from other firms.

Representative Firm Project Experience

Superior Fire Station, Superior, WI [2016-2017]
Scope: Structural Engineer of Record (SER) – 22,000 SF Single Story facility with partial Second Level

Grand Rapids Public Safety Building- Grand Rapids, MN [2020-2021]
Scope: Structural Engineer of Record (SER) – 18,000 SF Single Story facility plus partial second level.

LaPointe Emergency Services Building, La Pointe WI [2020-2021] Scope: Structural Engineer of Record – 12,000 SF Fire and EMS facility. Pre-engineered structure.

Chisholm Public Safety Building, Chisholm, MN [2020-2023]
Scope: Structural Engineer of Record (SER) – New 22,000 SF Public Safety Building.

Cold Springs Public Safety Building, Cold Springs, MN [2023-Current]
Scope: Structural Engineer of Record (SER) – New Construction, 16,000 SF Single Story plus partial second level facility

Greenville Fire Station – Greenville WI [2018-2019]
Scope: Structural Engineer of Record (SER)– New Construction. Single Story with partial second floor, 25,000 SF facility

Wausau Fire Station- Wausau, WI [2018-2019] Scope: Structural Engineer of Record (SER) – New 17,000 SF single story with partial second level

Bloomington Fire Station-Bloomington, MN [2018-2019] Scope: Structural Engineer of Record (SER) – New 29,000 SF single story with partial second level



Mission: To enhance our communities through creative, passionate & inspired services

Since 1998, JSD Professional Services, Inc. (JSD), has grown from one office with two employees to eight offices across four states. Strategically placed to serve local, regional and national clients, JSD's staff includes civil and structural engineers, surveyors, planners, landscape architects, and development services specialists who are all focused on delivering exceptional services from project concept through ribbon cutting.

Our multi-disciplined approach provides our clients with a coordinated team of specialists who have a broad knowledge base in creative design, site evaluation, project financing, municipal entitlements, land survey documentation, site infrastructure, municipal infrastructure and construction.

SERVICES

- Civil Engineering
- Land Surveying & Mapping
- Landscape Architecture
- Planning
- Development Services
- Environmental Services
- Construction Services
- Transportation Engineering
- Structural Engineering
- Water Resources

REGIONAL OFFICES

Madison, WI

507 W. Verona Ave, Suite 500, Verona, WI 53593 | (608) 848-5060

Wausau, WI

7402 Stone Ridge Dr, Suite 4, Weston, WI 54476 | (715) 298-6330

Milwaukee, WI

W238 N1610 Busse Rd, Suite 100, Waukesha, WI 53188 | (262) 513-0666

Appleton, WI

3215 W. Lawrence St, Suite 6, Appleton, WI 54914 | (920) 733-2800

Chicago, IL

1400 E. Touhy Ave, Suite 215, Des Plaines, IL 60018 | (312) 644-3379

Coeur d'Alene, ID

418 E. Lakeside Ave, Suite 221, Coeur d'Alene, ID 83814 | (847) 682-9420

Alexandria, MN

1206 3rd Ave. East, Alexandria, MN 56308 | (320) 763-6855

Minneapolis, MN

Coming Soon

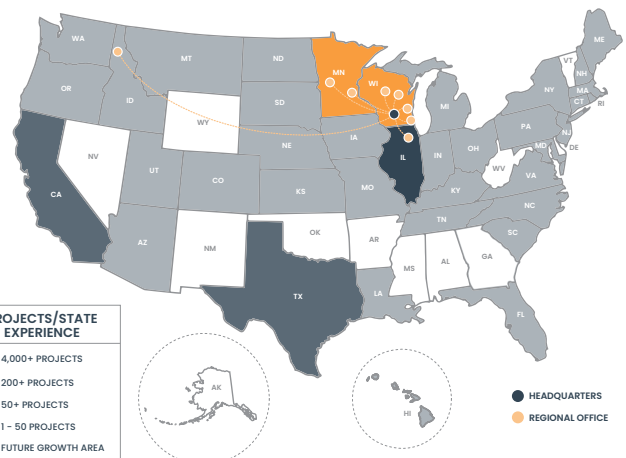



Kevin Yeska, PLA, ASLA – Project Manager

With over 12 years of experience, Mr. Yeska serves as a project consultant and landscape architect with expertise in commercial, institutional and residential design. His designs and approachable communication skills present his client and the general public with a contemporary “pop”, as he likes to call it! Additionally, Mr. Yeska not only understands the municipal entitlement process, but has extensive experience in critically laying out sites to meet municipal requirements relating to site access, parking accommodations, and designing open green spaces, all of which aid in establishing a “sense of place” for the design.

Relevant Experience:

City of Madison Fire Station No. 6 Remodel/Addition, Madison, WI

City of Baraboo Fire Station 1 & 2 (new facilities), Baraboo, WI

City of Platteville Fire Station (new facility), Platteville, WI

Lakeside Fire District Fire Stations, Edgerton, WI

City of Fitchburg Police Station (new facility), Fitchburg, WI



Steve Brueggeman, PE – Senior Civil Engineer

Mr. Brueggeman brings over 31 years of experience in project design and construction management for site development, municipal and transportation related engineering projects. Mr. Brueggeman has also served in the role of Public Works Director. His diverse private and public project experience includes supervisory, technical, and client relations roles from initial concept through final construction.

Relevant Experience:

Outagamie County 911 Call Center, Appleton, WI

*Freedom Municipal Building Planning, Freedom, WI**

*Town Hall Site Modifications, Hobart, WI**

*Freedom West Industrial Park, Freedom, WI**

*Parkview Drive Urbanization, Greenville, WI**



Todd Buhr, PLS – Director of Surveying

Mr. Buhr manages JSD survey operations for all regional locations. His duties include performing and coordinating survey project workload between offices, staffing, QA/QC, department and capital improvement budgets and company standards. He has over 30 years of land survey coordination, project management and staff management experience in the public and private sector. Mr. Buhr’s expertise is in managing and performing land surveying tasks on transportation project plats, right-of-way plats, large utility corridor projects with major private utility companies, airport surveys, stadium projects, private development, railroad surveys, condominiums, subdivisions, municipal projects, and construction observation projects.

Relevant Experience:

City of Baraboo Fire Station 1 & 2 (new facilities), Baraboo, WI

City of Fitchburg Police Station (new facility), Fitchburg, WI

City of Platteville Fire Station (new facility), Platteville, WI

City of Madison Fire Station No. 6 Remodel/Addition, Madison, WI

Juneau County Health and Human Services, Mauston, WI

*prior to joining JSD

JSD Relevant Experience

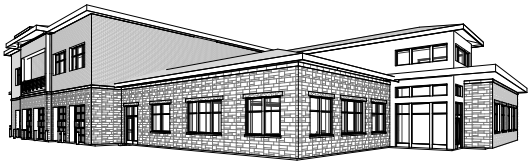

Baraboo Fire Station #1 & #2

BARABOO, WI

The City of Baraboo was advised by their community and others to consider building two fire and EMS stations due to the projected housing growth within the City. JSD provided engineering and landscape architecture services for the proposed developments. The projects followed an SD-DD-CD deliverable process for eventual submittal to USDA for funding approvals. Each project developed at the same time in design and construction.

Project Size: 99 Units

Project Completion: In Progress

Monona Public Safety Facility Feasibility Study

MONONA, WI

JSD provided civil engineering and landscape architecture services for a feasibility study to identify if a building that met the needs of the city would work on the current site. JSD considered several different design options; recommending one that would meet all goals of the project and address the following: lack of adequate sleeping quarters, undersized offices and radio room, undersized apparatus bay, lack of meeting and training space, and lack of necessary storage areas.

Project Size: \$48 Million

Project Completed: 2022



Waukesha Police Department

WAUKESHA, WI

The City of Waukesha hired a consultant to address current water leaks in a variety of locations at the Waukesha Police Department. After analysis and discussions with the city, it was decided to modernize all the building systems, enlarge the existing building and make improvements to the entire site. JSD provided design services including schematic design, design development and final construction documents. JSD also supported with Construction Administration services, as needed, for the awarded General Contractor.

Project Size: 81,000 Square Feet

Project Completed: 2022

City of Platteville Fire Station

PLATTEVILLE, WI

JSD is providing professional consulting, civil engineering landscape architecture, and construction services for the proposed development. Design services include schematic design, design development, and construction documents. The new Fire Station will have an increased apparatus bay and the creation of a decontamination area for firefighters returning from response calls and living spaces for future full-time firefighters.

Project Size: 35,525 Square Feet

Project Completed: Spring 2025





05

Proposed Services



Project Approach

Wendel Companies, home to the award-winning Five Bugles Design (FBD) and Mitchell Associates Architects (MAA), have reviewed the Village of Germantown's Request for Proposals for professional design services for the Village's Fire Station #2 project.

We understand that the Village has been reviewing the possibility of addressing their facility needs for the last several years and we are excited to potentially help the Village realize its goals. We are prepared to work with the Village's project management team indicated in the request for proposals. Our team is built to provide for the processes of programming and conceptual design, bidding documents, and ultimately construction for a remodeled facility that will be considered state of the art when finished, and we are excited to offer our services to the Village of Germantown.

As you will see from our proposal, our team has the experience required to lead this exciting project. We are extremely excited about recently acquiring Mitchell Associates Architects, a leader in emergency services design that rivals our own experience here at Five Bugles Design. Five Bugles Design and Mitchell Associates Architects have formed a relationship over the last few years due to the commonality we share, designing state-of-the-art functional emergency service facilities. Now we are one team with over a dozen individuals who have dedicated their careers in architecture to emergency services design, full-time. Highlights include:

- **Our director of emergency services and principal-in-charge, Robert Krzyzanowski**, has completed construction documents/construction administration on over 60 public safety facilities in his career, on top of over one hundred studied.
- **As a licensed architect (WI) and interior designer, Laura Eysnogle** has had the pleasure of working on emergency services facilities in twelve (12) states across the country, sharing all knowledge, challenges and solutions from each department with the next department as our project leader.
- **Bob Mitchell has been designing fire stations for more than thirty years**, with 195 projects addressing more than 330 public safety facilities. Thirty of these have won national awards,

*Our clients use words like **functionality, durability, energy efficiency, and comfort** when talking about **our firm's designs.***

including seven gold prizes.

- **Our senior emergency services specialist, James Schmidt**, has extensive experience both as an owner representative for three fire/EMS stations and one regional training center and assisted in the conceptual or final design of over seventy (70) emergency services facilities across the country.

Looking at the Village's objectives, we see that you have extensive expectations that our team also strives for. Your fire staff are not only employees of the Village, but most of them also call Germantown home, and that is important. A significant part of a project's success is incumbent upon the expectations established early on. Our team hopes to assist the Village in creating a vision that everyone can be proud of moving forward and in keeping the community up to speed on progress.

Our clients use words like functionality, durability, energy efficiency, and comfort when talking about our firm's designs. We take pride in function over fancy but can also provide a superior facility design that will serve Germantown without breaking the budget, and while meeting the various codes of the Village and the State of Wisconsin.

Our company is a one-stop shop if the client desires. FBD and MAA are niche services under the Wendel Companies umbrella, our company has all the services of Architecture, Engineering, Energy Efficiency and Construction Management under one roof. We can offer all these services to the Village without the need for multiple partners, and we are offering Architecture, HVAC, Plumbing, Electrical and Fire suppression as in-house services.

For this project, NCE and JSD are our subconsultants. NCE will perform structural design, and our teams have been exclusively using their services for the last 16 years since our inception. JSD will perform civil design with current project work occurring with us in Lakeside, Baraboo and Platteville. Both firms have the expertise and experience to deliver an unparalleled project to the Village that will be a permanent building for generations to come.

We have reviewed the entire proposal and scope of services as indicated in the Request for Proposals and we are prepared to complete those tasks. We look forward to the opportunity to work closely with the Village of Germantown project team and to turn your dreams into reality.



PROJECT APPROACH

Five Bugles Design understands the Village of Germantown is seeking qualifications from interested firms to provide Architectural and Engineering services for the Village's Fire Station #2.

Services and responsibilities of the architectural and engineering team will include:

PHASE 1: SCHEMATIC DESIGN SERVICES

- A. Review Existing Conditions and Document
- B. Programming and space planning
- C. Site analysis and evaluation
- D. Conceptual design options
- E. Preliminary cost estimates
- F. Presentation to Elected Officials

PHASE 2: DESIGN SERVICES - PLAN DEVELOPMENT

- G. Design Development
- H. Construction Drawings and Specifications
- I. Bidding Services

PHASE 3: CONSTRUCTION ADMINISTRATION

- J. Regular site visits and construction oversight
- K. Review and approval of submittals, shop drawings, and contractor payment requests
- L. Respond to Requests for Information (RFIs)
- M. Ensure compliance with project specifications and timelines
- N. Final inspections and punch list oversight
- O. Provide building and HVAC compliance statements to the State of Wisconsin as the supervising professional

Our team will be an integral part in helping educate and communicate with Germantown residents the needs of the department through various public education initiatives. Our team will be available to provide educational information and in-person question and answer meetings to residents.

We will evaluate costs and constructability of the potential facility and provide accurate pricing based on historical data.

FBD/MAA has performed this service for clients across country. Ultimately, we believe the path listed above is a winning approach to help guide local leaders through this process.

DESCRIPTION OF WORK PERFORMED

Our team has developed a unique process that is inclusive, efficient, and comprehensive. It brings together all of the stakeholders in a series of intense, on-site planning sessions. This allows for us to maintain aggressive project schedules while being flexible enough to react to the busy schedules of various stakeholders.

PROJECT SCOPE

Phase 1: Schematic Design Services

Existing Condition Assessments: Review of the existing conditions is a critical component of this process. Reviewing the existing facility and essentially telling the story of why an updated facility is needed is the very first step. Our architects and engineers will review and provide written documentation to assist Village leaders in making an informed decision to justify moving forward with certain areas of remodel and to justify why additions are needed. We will document these conditions in an existing conditions survey that will be included within the final deliverable.

Programming/Space Needs Analysis: Our emergency service designers and specialists will lead a programming effort aimed at blending the combined knowledge of your staff regarding your operations with our understanding of space requirements and facility design. We will consider potential growth and will challenge your department to think about the future, but still remain fiscally responsible. Through our combined efforts, we will develop a preliminary facility size and potential costs that will be reviewed with the project team leadership to verify the project is within acceptable parameters or expectations and discuss next steps.

Correct programming is the single most important step in the design of your facility. We bring to the table our deep knowledge of firematic operations, building/site issues, equipment, training, and personnel needs based on our years of experience working closely with the emergency services community. The programming process is based on actively listening to you and assisting you to define the needs and goals for your facility and offering our expert advice.

We use proprietary programming tools and techniques developed by us specifically for our projects. The program for your project will be developed from a series of in-depth programming meetings with your building committee.

- The program document is utilized to determine the scope of the total project.
- It is your opportunity to describe your operations and other activities within the building and on the site. It identifies your priorities, the building's potential impact on response and operational issues, training opportunities, necessary adjacencies, and areas of economy.
- The program is a dynamic tool that can provide for flexibility over time and plan alternative responses to future growth.
- Diagrams are provided to explain each room to assure that the intended activity is correctly understood and accommodated, and that the correct size has been chosen.
- Room locations and adjacencies will be determined to support the evolution of your operations, not to be an impediment.
- Assumptions regarding calculated areas for corridors & walls are validated against a database of similar fire stations.
- Based on the program, a space usage analysis spreadsheet is created that specifies probable room and building size.
- All of this combines to be the tool that allows us, the client and architect, to determine that the project direction is correct and within budget prior to starting any drawings.

Task A:
Existing
Condition Assessments

Task B:
Programming/
Space Needs Analysis

A proper program:

1. Reassures all participants and the public that the decisions made are valid.
2. Confirms the initial budget, or clearly identifies any required compromises between wishes and affordability before the building is designed.
3. Informs and simplifies the design process.
4. Minimizes the possibilities to look back and say, “I wish we had thought of that.”

Task C:

Site Analysis and Evaluation

Site Analysis and Evaluation: Our team will work with you to assess and develop options of appropriate additions, revised site layout and potential phasing issues. This will result in necessary information fire station leaders can use in making well-thought-out decisions. Our team will develop multiple options complete with cost estimates and pros and cons.

Task D:

Conceptual Design Options

Conceptual Design Options: Once programming is completed, our team will review that data from Task, and prepare conceptual options on the site. Costs will be associated to these options and reviewed with the team. We will then review these efforts with Project Management and all Stakeholders seeking comment with the goal of customizing the design effort to your departments and its specific operational procedures and concerns.

Task E:

Preliminary Cost Estimates & Draft Report

Estimates Of Probable Cost, Tax Impact And Draft Report: We will create Estimates of Probable Cost at the first meeting and refine them throughout the process. We will discuss additional project-related costs in the report to provide as much information to the community as possible. Our Estimates of Cost are detailed and include a breakdown of all anticipated project costs including site acquisition, site development, building construction, FF&E, technology, contingencies, review fees and legal costs. A draft of the report will be available for review and comment.

Task F:

Present to Elected Officials

Finalize Draft Report /Present To Village Leaders: When estimated costs of construction come forward, adjustments will occur to the conceptual plans as well as the site. Our team will review the draft report and make adjustments after conversations with the end users and department heads. After all stakeholder edits are made, a detailed draft report showing all programming efforts, conceptual site/floor plans and estimates of probable costs will be presented to Village leaders. Adjustments will then occur after this meeting for a final presentation of the final report to the Village if required.

Task G:

Design Development

PHASE 2: Design Services - Plan Development

Below is a brief explanation on how our team will move forward with the tasks of Phase 2. There are many factors to consider when moving forward into the Phase 2 – Design scope of work and our team will assist and point the Village in the right direction. The following items are to be considered, but not limited to, before moving forward with Phase 2:

- a. Project delivery method, General Contractor or Construction Manager.
 - b. Cost Analysis of various building materials and value engineering.
 - c. Various Funding Mechanisms.
 - d. Review of Site Conditions beyond work completed in Phase 1.
1. Obtain existing site drawings for review and visit site to confirm existing conditions and future opportunities.
 2. Evaluate potential building system options (architectural/civil/structural/mechanical/electrical/ etc.) and perform a very high level design assessment to confirm their feasibility.
 3. Review and evaluate potential sustainable features and whether LEED certification is desired by the Village, complete with potential payback possibilities.
 4. Refine the schematic floor diagram and site plan preferred alternatives based on the above assessments.
 5. Prepare a high-level, square foot-based budget opinion of probable project costs.

**Surveying, and Geo-technical services will be paid for directly by the owner, but our team will coordinate the RFP process and selection of these partners.*

Task H: Construction Documents

6. Meet with owner to review preferred plans, building system options and budget costs and determine the next course of action.
 7. Advance the preferred building and site plans to the approximately 30% complete, preliminary design stage and prepare the following drawings:
 - Site layout plan
 - Architectural floor plans
 - Two colored, computer generated building renderings
 - * 8. Retain the services of a qualified firm to prepare a preliminary geotechnical investigation to assess preliminary building addition foundation system design requirements. Detailed geotechnical investigation will be prepared prior to the start of final design.
 - * 9. Retain the services of a qualified surveyor to perform a preliminary topographic survey of the site and prepare a base map for use in preliminary design. Detailed topographic and utility service survey will be prepared prior to the start of final design.
1. Prepare a Basis of Design Document for Village's review and concurrence including space program requirements, building code and system design requirements, site access, circulation and parking requirements, utility service requirements, energy efficiency and sustainability requirements, etc.
 2. Conduct preliminary discussions with utility service providers (electric, gas, water, sanitary sewer, etc.) to confirm service load requirements.
 3. Perform building and zoning code review and meet with local building officials to confirm concurrence with building and site requirements.
 4. Refine assessment of potential building architectural, structural, mechanical, electrical systems.
 5. Evaluate potential energy savings funding options and incentives.
 6. Prepare preliminary design level opinion of probable project costs.
 7. Meet with the Village to review preliminary building and site plans, potential building system requirements and preliminary design budget costs and determine the next course of action.
 8. Prepare updated building code review and code compliance drawings showing exiting requirements, fire separations, etc.
 9. Based on the approved preliminary design report, prepare Construction Drawings and Technical Specifications suitable for competitive bidding that describe the size and character of facility systems and materials for each of the following disciplines:
 - Architectural
 - Structural
 - Civil
 - Landscaping
 - HVAC
 - Plumbing
 - Electrical
 10. Refine the current 3D building perspectives based at the completion of the 70% design completion stage.
 11. Present final Construction Documents to the Village for sign-off and determine the next course of action for this project.

Task I: Bidding Services

Bidding and construction services are the backbone of our services. Our teams are accustomed to performing construction duties on projects that are often considered long rides and being close to home will ensure a superior product for Germantown.

1. Attend pre-bid meeting/site walk-thru and issue meeting minutes.
2. Process RFI's and assist with assembling addendum.
3. Attend a meeting with Owner to review bid recommendations and determine selected contractors for each bid package.

Phase 3: Construction Administration

1. Construction Kick-Off Meeting
 - The construction phase will be initiated by a kick-off meeting between the owner, the design team, the project coordinator and the successful contractors. This meeting will set the parameters for the construction phase process and the expectations for all aspects of the work.
2. Construction Review and Observation
 - Attend bi-weekly construction meetings during an assumed construction duration with the owner, the design team, the project coordinator and the successful contractors to review and coordinate the progress of construction.
 - Perform periodic, technical site visits at intervals appropriate to the stage of the contractor's operations to determine if the project is being constructed in general conformance with to the construction documents and the design intent.
 - Site visit reports will be prepared and submitted to the Owner and contractors, indicating the work performed that day, weather conditions, and noting any significant observations or decisions made while on site.
3. Requests for Information and Design Support
 - Record and respond to Contractor Requests for Information (RFI).
 - Provide design responses to unanticipated or changed conditions.
 - Provide interpretation and clarification of design intent and make recommendations to the fire department regarding proposed changes.
4. Shop Drawings and Submittals
 - The design team will work closely with the project coordinator to provide shop drawing and submittal review on a timely basis.
 - Shop drawings and submittals will be reviewed for general conformance with the construction documents and the design intent.
5. Contractor Pay Applications
 - Review and certify the contractor's monthly applications for payment and make appropriate recommendations to the fire department.
6. Change Proposal Requests and Change Orders
 - Prepare additional work proposal requests, change order documentation and supplemental design documentation.
7. Punch List
 - Assist the fire department and project coordinator in determining the dates of substantial completion and final completion and prepare a punch list of outstanding contractor items at substantial completion.





Order by Score				
Firm	Lump Sum	Percentage		Score
SEH	\$487,500 \$436,500			85.83
Wendel		7.9%	\$481,900	83.50
Bray		6.5%	\$396,500	65.83
Angus-Young	\$334,250			64.67
Kueny*		4.5%	\$289,750	64.00
PRA/GRAEF	\$424,900			61.67
FGMA	\$490,000			60.50

Order by Cost			
Firm	Lump Sum	Percentage	
Kueny*		4.5%	\$289,750
Anges-Young	\$334,250		
Bray		6.5%	396,500
PRA/GRAEF	\$424,900		
SEH	\$487,500 \$436,500		
Wendel		7.9%	\$481,900
FGMA	\$490,000		
Average with Highest/Lowest Excluded - \$425,010			

SEH Negotiated Fee Breakdown			
Professional Service	Initial Proposed Service Fee	Negotiated Service Fee	Fee Reduction
Architectural	\$255,000	\$223,000	\$32,000
Structural	\$65,000	\$65,000	\$0
Civil	\$49,000	\$44,000	\$5,000
MEP and FP	\$96,000	\$90,000	\$6,000
Landscape	\$8,000	\$0	\$8,000
Interior Design	\$4,500	\$4,500	\$0
Envelope Consultant	\$5,000	\$5,000	\$0
Expenses	\$5,000	\$5,000	\$0
Subtotal of Professional Services	\$487,500	\$436,500	\$51,000
Additional Services	Initial	Negotiated	Reduction
Focus on Energy	\$2,500	\$2,500	\$0
Environmental Testing	\$7,500	\$7,500	\$0
Geotechnical Engineering	\$7,500	\$7,500	\$0
Subtotal of Additional Services	\$17,500	\$17,500	\$0
Total of Services	\$505,000	\$454,000	\$51,000

AIA® Document B101® – 2017

Standard Form of Agreement Between Owner and Architect

AGREEMENT made as of the 24th day of November in the year 2025
(In words, indicate day, month and year.)

BETWEEN the Architect's client identified as the Owner:
(Name, legal status, address and other information)

Village of Germantown
John Delain
N115W18752 Edison Drive
Germantown, WI 53022

and the Architect:
(Name, legal status, address and other information)

Short Elliott Hendrickson Inc.
425 West Water Street, Suite 300
Appleton, WI 54911-6058
920.380.2800

for the following Project:
(Name, location and detailed description)

Germantown Fire Station #2 Remodel & Expansion

The Owner and Architect agree as follows.

ADDITIONS AND DELETIONS:
The author of this document may have revised the text of the original AIA standard form. An *Additions and Deletions Report* that notes revisions to the standard form text is available from the author and should be reviewed. A vertical line in the left margin of this document indicates where the author has added to or deleted from the original AIA text.

This document has important legal consequences. Consultation with an attorney is encouraged with respect to its completion or modification.

ELECTRONIC COPYING of any portion of this AIA® Document to another electronic file is prohibited and constitutes a violation of copyright laws as set forth in the footer of this document.

TABLE OF ARTICLES

- 1 INITIAL INFORMATION
- 2 ARCHITECT'S RESPONSIBILITIES
- 3 SCOPE OF ARCHITECT'S BASIC SERVICES
- 4 SUPPLEMENTAL AND ADDITIONAL SERVICES
- 5 OWNER'S RESPONSIBILITIES
- 6 COST OF THE WORK
- 7 COPYRIGHTS AND LICENSES
- 8 CLAIMS AND DISPUTES
- 9 TERMINATION OR SUSPENSION
- 10 MISCELLANEOUS PROVISIONS
- 11 COMPENSATION
- 12 SPECIAL TERMS AND CONDITIONS
- 13 SCOPE OF THE AGREEMENT

ARTICLE 1 INITIAL INFORMATION

§ 1.1 This Agreement is based on the Initial Information set forth in this Section 1.1.

(For each item in this section, insert the information or a statement such as "not applicable" or "unknown at time of execution.")

§ 1.1.1 The Owner's program for the Project:

(Insert the Owner's program, identify documentation that establishes the Owner's program, or state the manner in which the program will be developed.)

Use previously programmed room square footages based on completed fire station space needs study. Architect will provide review and consultation of programmed spaces and provide feedback and recommendations on study findings consistent with the Architect's Basic Services and without assuming responsibility for the accuracy or completeness of the Owner's program.

§ 1.1.2 The Project's physical characteristics:

(Identify or describe pertinent information about the Project's physical characteristics, such as size; location; dimensions; geotechnical reports; site boundaries; topographic surveys; traffic and utility studies; availability of public and private utilities and services; legal description of the site, etc.)

Not available at time of Contract and will be provided by the Owner when and if available, without warranty as to accuracy or completeness.

§ 1.1.3 The Owner's budget for the Cost of the Work, as defined in Section 6.1:

(Provide total and, if known, a line item breakdown.)

Initial cost estimates during the RFP phase for the building were roughly \$6,100,000, which are preliminary, non-binding, and

provided for general budgeting purposes only, depending on the type of construction and the features that were to be designed into the facility.

§ 1.1.4 All milestone dates identified in this Section are anticipated targets only, subject to adjustment for approvals, funding, agency review, and other factors beyond the Architect's control. However, Architect shall endeavor to meet these milestone dates subject to reasonable adjustments based upon those matter beyond Architect's control. The Owner's anticipated design and construction milestone dates:

.1 Design phase milestone dates, if any:

30% design and estimate are to be targeted for completion April 2026
60% design and estimate are to be targeted for completion August 2026
90% design and estimate are to be targeted for completion November 2026
Final bid documents should be prepared for delivery by January 2027

.2 Construction commencement date:

March 2027

.3 Substantial Completion date or dates:

February 2028

.4 Other milestone dates:

Local and State reviews as required by the Village and various agencies.

§ 1.1.5 The Owner intends the following procurement and delivery method for the Project:

(Identify method such as competitive bid or negotiated contract, as well as any requirements for accelerated or fast-track design and construction, multiple bid packages, or phased construction.)

Design, bid, and construct utilizing a Construction Manager that will execute an open bid process once the construction and Contract documents have been prepared. The Contract with the Contractor for construction will be a CM at Risk. The Architect shall not be responsible for the means, methods, sequencing, safety, or cost guarantees associated with the CM at Risk delivery method.

§ 1.1.6 The Owner's anticipated Sustainable Objective for the Project:

(Identify and describe the Owner's Sustainable Objective for the Project, if any.)

The sustainability features have not been identified at this time of this Contract. Design for sustainable systems is in addition to the Architect's Basic Services and shall require prior written authorization by the Owner, following completion of a cost/benefit analysis for any particular sustainable building system.

§ 1.1.6.1 If the Owner identifies a Sustainable Objective, the Owner and Architect shall complete and incorporate AIA Document E204™–2017, Sustainable Projects Exhibit, into this Agreement to define the terms, conditions and services related to the Owner's Sustainable Objective. If E204–2017 is incorporated into this agreement, the Owner and Architect shall incorporate the completed E204–2017 into the agreements with the consultants and contractors performing services or Work in any way associated with the Sustainable Objective.

§ 1.1.7 The Owner identifies the following representative in accordance with Section 5.3:

(List name, address, and other contact information.)

John Delain, Fire Chief (or such other representative designated in writing by the Owner from time to time)
jdelain@germantownwi.gov
N115W18752 Edison Drive
Germantown, WI 53022

§ 1.1.8 The persons or entities, in addition to the Owner’s representative, who are required to review the Architect’s submittals to the Owner are as follows:

(List name, address, and other contact information.)

Village Administrator, Director of Public Works, Village Engineer, Village Attorney, and such other representatives or consultants as the Owner may designate.

§ 1.1.9 The Owner shall retain the following consultants and contractors:

(List name, legal status, address, and other contact information.)

.1 Geotechnical Engineer:

N/A

.2 Civil Engineer:

N/A

.3 Other, if any:

(List any other consultants and contractors retained by the Owner.)

N/A

§ 1.1.10 The Architect identifies the following representative in accordance with Section 2.3:

(List name, address, and other contact information.)

Trevor M. Frank, AIA tfrank@sehinc.com

Mark Zvitkovits, AIA mzvitkovits@sehinc.com

§ 1.1.11 The Architect shall retain the consultants identified in Sections 1.1.11.1 and 1.1.11.2:

(List name, legal status, address, and other contact information.)

§ 1.1.11.1 Consultants retained under Basic Services:

.1 Structural Engineer:

SEH Structural Engineering staff

.2 Mechanical Engineer:

MSA Professional Services

.3 Electrical Engineer:

MSA Professional Services

§ 1.1.11.2 Consultants retained under Supplemental Services:

raSmith

Atmosphere Commercial Interiors

STR-SEG

Intertek – PSI

The Architect shall be responsible for the coordination, integration, and performance of its consultants consistent with this

Agreement.

§ 1.1.12 Other Initial Information on which the Agreement is based:

N/A

§ 1.2 The Owner and Architect may rely on the Initial Information. Both parties recognize that the Initial Information may materially change and, in that event, the Owner and the Architect shall by written amendment appropriately adjust the Architect's services, schedule, and compensation to the extent directly affected by such material change.

§ 1.3 The parties shall agree upon written protocols governing the transmission and use of, and reliance on, Instruments of Service or any other information or documentation in digital form.

§ 1.3.1 Any use of, or reliance on, all or a portion of a building information model without agreement to written protocols governing the use of, and reliance on, the information contained in the model shall be at the using or relying party's sole risk except to the extent such use is expressly authorized by the Architect in writing and without liability to the other party and its contractors or consultants, the authors of, or contributors to, the building information model, and each of their agents and employees.

ARTICLE 2 ARCHITECT'S RESPONSIBILITIES

§ 2.1 The Architect shall provide professional services as set forth in this Agreement. The Architect represents that it is properly licensed in the jurisdiction where the Project is located to provide the services required by this Agreement, or shall cause such services to be performed by appropriately licensed design professionals.

§ 2.2 The Architect shall perform its services consistent with the professional skill and care ordinarily provided by architects practicing in the same or similar locality under the same or similar circumstances. The Architect shall perform its services as expeditiously as is consistent with such professional skill and care and the orderly progress of the Project. Nothing in this Agreement shall be construed to impose upon the Architect a standard of care higher than that required by this Section or to create any warranty, guarantee, or assurance of project outcomes, cost, or schedule.

§ 2.3 The Architect shall identify a representative authorized to act on behalf of the Architect with respect to the Project, provided that such authority shall not extend to approving changes in scope, cost, or schedule without the Owner's prior written approval.

§ 2.4 Except with the Owner's knowledge and consent, the Architect shall not engage in any activity, or accept any employment, interest or contribution that would reasonably appear to compromise the Architect's professional judgment with respect to this Project.

§ 2.5 The Architect shall maintain the following insurance until termination of this Agreement. If any of the requirements set forth below are in addition to the types and limits the Architect normally maintains, the Owner shall pay the Architect as set forth in Section 11.9. The Architect shall provide the Owner with not less than thirty (30) days' prior written notice of any cancellation, non-renewal, or material reduction in coverage.

§ 2.5.1 Commercial General Liability with policy limits of not less than one million dollars (\$1,000,000) for each occurrence and two million dollars (\$2,000,000) in the aggregate for bodily injury and property damage.

§ 2.5.2 Automobile Liability covering vehicles owned, and non-owned vehicles used, by the Architect with policy limits of not less than one million dollars (\$1,000,000) per accident for bodily injury, death of any person, and property damage arising out of the ownership, maintenance and use of those motor vehicles, along with any other statutorily required automobile coverage.

§ 2.5.3 The Architect may achieve the required limits and coverage for Commercial General Liability and Automobile Liability through a combination of primary and excess or umbrella liability insurance, provided such primary and excess or umbrella liability insurance policies result in the same or greater coverage as the coverages required under Sections 2.5.1 and 2.5.2, and in no event shall any excess or umbrella liability insurance provide narrower coverage than the primary policy. The excess policy shall not require the exhaustion of the underlying limits only through the actual payment by the underlying insurers.

§ 2.5.4 Workers' Compensation at statutory limits.

§ 2.5.5 Employers' Liability with policy limits not less than one million dollars (\$1,000,000) each accident, one million dollars (\$1,000,000) each employee, and one million dollars (\$1,000,000) policy limit.

§ 2.5.6 Professional Liability covering negligent acts, errors and omissions in the performance of professional services with policy limits of not less than five million dollars (\$5,000,000) per claim and ten million dollars (\$10,000,000) in the aggregate. Such coverage shall be maintained for a period of not less than five (5) years following Substantial Completion or termination of this Agreement, whichever occurs later.

§ 2.5.7 **Additional Insured Obligations.** To the fullest extent permitted by law, the Architect shall cause the primary and excess or umbrella policies for Commercial General Liability and Automobile Liability to include the Owner as an additional insured for claims caused in whole or in part by the Architect's negligent acts or omissions. The additional insured coverage shall be primary and non-contributory to any of the Owner's insurance policies and shall apply to both ongoing and completed operations in the performance of this Agreement.

§ 2.5.8 The Architect shall provide certificates of insurance to the Owner that evidence compliance with the requirements in this Section 2.5 and shall provide copies of required endorsements and policies upon the Owner's reasonable request.

§ 2.6 **No Third-Party Reliance.** Nothing in this Agreement shall be deemed to create any duty or obligation on the part of the Architect to any third party, including contractors, subcontractors, or suppliers, nor any right of reliance by any such party on the Architect's services or Instruments of Service.

ARTICLE 3 SCOPE OF ARCHITECT'S BASIC SERVICES

§ 3.1 The Architect's Basic Services consist of those described in this Article 3 and include usual and customary structural, mechanical, and electrical engineering services. Services not set forth in this Article 3 are Supplemental or Additional Services. Basic Services include all services reasonably necessary to provide a complete and code-compliant design and Construction Documents suitable for bidding and construction of the Project, consistent with the Owner's approved program and budget, except as expressly identified as Supplemental or Additional Services in this Agreement.

§ 3.1.1 The Architect shall manage the Architect's services, research applicable design criteria, attend Project meetings, communicate with members of the Project team, and report progress to the Owner. No Supplemental or Additional Services shall be performed, and no adjustment to compensation or schedule shall be owed, absent the Owner's prior written authorization (e.g., amendment, proposal approval, or written directive) identifying the scope and fee.

§ 3.1.2 The Architect shall coordinate its services with those services provided by the Owner and the Owner's consultants. The Architect shall be entitled to rely on, and shall not be responsible for, the accuracy, completeness, and timeliness of, services and information furnished by the Owner and the Owner's consultants, provided that the Architect shall exercise reasonable professional care in reviewing such information for apparent errors, omissions, or inconsistencies. The Architect shall provide prompt written notice to the Owner if the Architect becomes aware of any error, omission, or inconsistency in such services or information.

§ 3.1.3 As soon as practicable after the date of this Agreement, the Architect shall submit for the Owner's approval a schedule for the performance of the Architect's services. The schedule initially shall include anticipated dates for the commencement of construction and for Substantial Completion of the Work as set forth in the Initial Information. The schedule shall include allowances for periods of time required for the Owner's review, for the performance of the Owner's consultants, and for approval of submissions by authorities having jurisdiction over the Project. Once approved by the Owner, time limits established by the schedule shall not, except for reasonable cause, be exceeded by the Architect or Owner, and any schedule adjustments shall be documented in writing. With the Owner's approval, the Architect shall adjust the schedule, if necessary, as the Project proceeds until the commencement of construction. Owner review periods shall be subject to public-body meeting schedules, statutory/public procurement requirements, and availability of information, and shall not constitute a breach absent unreasonable delay under the circumstances.

§ 3.1.4 The Architect shall not be responsible for an Owner's directive or substitution, or for the Owner's acceptance of non-conforming Work, made or given without the Architect's written approval provided, that the Architect has timely advised the

Owner in writing of the nonconformity and associated impacts to cost, schedule, performance, or code compliance that are known to the Architect.

§ 3.1.5 The Architect shall contact governmental authorities required to approve the Construction Documents and entities providing utility services to the Project. The Architect shall respond to applicable design requirements imposed by those authorities and entities.

§ 3.1.6 The Architect shall assist the Owner in connection with the Owner's responsibility for filing documents required for the approval of governmental authorities having jurisdiction over the Project.

§ 3.2 Schematic Design Phase Services

§ 3.2.1 The Architect shall review the program and other information furnished by the Owner, and shall review laws, codes, and regulations applicable to the Architect's services.

§ 3.2.2 The Architect shall prepare a preliminary evaluation of the Owner's program, schedule, budget for the Cost of the Work, Project site, the proposed procurement and delivery method, and other Initial Information, each in terms of the other, to ascertain the requirements of the Project. The Architect shall notify the Owner of (1) any inconsistencies discovered in the information, and (2) other information or consulting services that may be reasonably needed for the Project.

§ 3.2.3 The Architect shall present its preliminary evaluation to the Owner and shall discuss with the Owner alternative approaches to design and construction of the Project. The Architect shall reach an understanding with the Owner regarding the requirements of the Project.

§ 3.2.4 Based on the Project requirements agreed upon with the Owner, the Architect shall prepare and present, for the Owner's approval, a preliminary design illustrating the scale and relationship of the Project components.

§ 3.2.5 Based on the Owner's approval of the preliminary design, the Architect shall prepare Schematic Design Documents for the Owner's approval. The Schematic Design Documents shall consist of drawings and other documents including a site plan, if appropriate, and preliminary building plans, sections and elevations; and may include some combination of study models, perspective sketches, or digital representations. Preliminary selections of major building systems and construction materials shall be noted on the drawings or described in writing.

§ 3.2.5.1 The Architect shall consider sustainable design alternatives, such as material choices and building orientation, together with other considerations based on program and aesthetics, in developing a design that is consistent with the Owner's program, schedule and budget for the Cost of the Work. The Owner may obtain more advanced sustainable design services as a Supplemental Service under Section 4.1.1.

§ 3.2.5.2 The Architect shall consider the value of alternative materials, building systems and equipment, together with other considerations based on program and aesthetics, in developing a design for the Project that is consistent with the Owner's program, schedule, and budget for the Cost of the Work.

§ 3.2.6 The Architect shall submit to the Owner an estimate of the Cost of the Work prepared in accordance with Section 6.3. The Architect's obligation is to provide professional recommendations and cost-estimating support consistent with Section 6.3 and does not constitute a warranty or guarantee that bids or actual construction costs will not exceed the Owner's budget.

§ 3.2.7 The Architect shall submit the Schematic Design Documents to the Owner, and request the Owner's approval.

§ 3.3 Design Development Phase Services

§ 3.3.1 Based on the Owner's approval of the Schematic Design Documents, and on the Owner's authorization of any adjustments in the Project requirements and the budget for the Cost of the Work, the Architect shall prepare Design Development Documents for the Owner's approval. The Design Development Documents shall illustrate and describe the development of the approved Schematic Design Documents and shall consist of drawings and other documents including plans, sections, elevations, typical construction details, and diagrammatic layouts of building systems to fix and describe the size and character of the Project as to architectural, structural, mechanical and electrical systems, and other appropriate elements. The Design Development Documents shall also include outline specifications that identify major materials and systems and establish, in general, their quality levels.

§ 3.3.2 The Architect shall update the estimate of the Cost of the Work prepared in accordance with Section 6.3.

§ 3.3.3 The Architect shall submit the Design Development Documents to the Owner, advise the Owner of any adjustments to the estimate of the Cost of the Work, and request the Owner's approval.

§ 3.4 Construction Documents Phase Services

§ 3.4.1 Based on the Owner's approval of the Design Development Documents, and on the Owner's authorization of any adjustments in the Project requirements and the budget for the Cost of the Work, the Architect shall prepare Construction Documents for the Owner's approval. The Construction Documents shall illustrate and describe the further development of the approved Design Development Documents and shall consist of Drawings and Specifications setting forth in detail the quality levels and performance criteria of materials and systems and other requirements for the construction of the Work. The Owner and Architect acknowledge that, in order to perform the Work, the Contractor will provide additional information, including Shop Drawings, Product Data, Samples and other similar submittals, which the Architect shall review in accordance with Section 3.6.4.

§ 3.4.2 The Architect shall incorporate the design requirements of governmental authorities having jurisdiction over the Project into the Construction Documents.

§ 3.4.3 During the development of the Construction Documents, the Architect shall assist the Owner in the development and preparation of (1) procurement information that describes the time, place, and conditions of bidding, including bidding or proposal forms; (2) the form of agreement between the Owner and Contractor; and (3) the Conditions of the Contract for Construction (General, Supplementary and other Conditions). The Architect shall also compile a project manual that includes the Conditions of the Contract for Construction and Specifications, and may include bidding requirements and sample forms.

§ 3.4.4 The Architect shall update the estimate for the Cost of the Work prepared in accordance with Section 6.3.

§ 3.4.5 The Architect shall submit the Construction Documents to the Owner, advise the Owner of any adjustments to the estimate of the Cost of the Work, take any action required under Section 6.5, and request the Owner's approval.

§ 3.5 Procurement Phase Services

§ 3.5.1 General

The Architect shall assist the Owner in establishing a list of prospective contractors. Following the Owner's approval of the Construction Documents, the Architect shall assist the Owner in (1) obtaining either competitive bids or negotiated proposals; (2) confirming responsiveness of bids or proposals; (3) determining the successful bid or proposal, if any; and, (4) awarding and preparing contracts for construction.

§ 3.5.2 Competitive Bidding

§ 3.5.2.1 Bidding Documents shall consist of bidding requirements and proposed Contract Documents.

§ 3.5.2.2 The Architect shall assist the Owner and Construction Manager in bidding the Project by:

- .1 facilitating the distribution of Bidding Documents to prospective bidders; Construction Manager lead, Architect assist.
- .2 organizing and conducting a pre-bid conference for prospective bidders; Construction Manager lead, Architect assist.
- .3 preparing responses to questions from prospective bidders and providing clarifications and interpretations of the Bidding Documents to the prospective bidders in the form of addenda; and,
- .4 organizing and conducting the opening of the bids, and subsequently documenting and distributing the bidding results, as directed by the Owner. Construction Manager lead, Architect assist.

§ 3.5.2.3 If the Bidding Documents permit substitutions, upon the Owner's written authorization, the Architect shall, as an Additional Service, consider requests for substitutions and prepare and distribute addenda identifying approved substitutions to all prospective bidders.

§ 3.6 Construction Phase Services

§ 3.6.1 General

§ 3.6.1.1 The Architect shall provide administration of the Contract between the Owner and the Contractor as set forth below and in AIA Document A201™–2017, General Conditions of the Contract for Construction. If the Owner and Contractor modify AIA Document A201–2017, those modifications shall not affect the Architect’s services under this Agreement unless the Owner and the Architect amend this Agreement, provided that clarifications of administrative procedures, risk allocation, or Owner remedies in the Owner-Contractor agreement shall not, by themselves, constitute an increase in the Architect’s Basic Services.

§ 3.6.1.2 The Architect shall advise and consult with the Owner during the Construction Phase Services. The Architect shall have authority to act on behalf of the Owner only to the extent provided in this Agreement. The Architect shall not have control over, charge of, or responsibility for the construction means, methods, techniques, sequences or procedures, or for safety precautions and programs in connection with the Work, nor shall the Architect be responsible for the Contractor’s failure to perform the Work in accordance with the requirements of the Contract Documents. The Architect shall be responsible for the Architect’s negligent acts or omissions, but shall not have control over or charge of, and shall not be responsible for, acts or omissions of the Contractor or of any other persons or entities performing portions of the Work.

§ 3.6.1.3 Subject to Section 4.2 and except as provided in Section 3.6.6.5, the Architect’s responsibility to provide Construction Phase Services commences with the award of the Contract for Construction and terminates on the date the Architect issues the final Certificate for Payment or such later date as necessary to complete the Architect’s closeout obligations under Section 3.6.6.

§ 3.6.2 Evaluations of the Work

§ 3.6.2.1 The Architect shall visit the site at intervals appropriate to the stage of construction, or as otherwise required in Section 4.2.3, to become generally familiar with the progress and quality of the portion of the Work completed, and to determine, in general, if the Work observed is being performed in a manner indicating that the Work, when fully completed, will be in accordance with the Contract Documents. However, the Architect shall not be required to make exhaustive or continuous on-site inspections to check the quality or quantity of the Work. On the basis of the site visits, the Architect shall keep the Owner reasonably informed about the progress and quality of the portion of the Work completed, and promptly report to the Owner (1) known deviations from the Contract Documents, (2) known deviations from the most recent construction schedule submitted by the Contractor, and (3) defects and deficiencies observed in the Work.

§ 3.6.2.2 The Architect has the authority to reject Work that does not conform to the Contract Documents. Whenever the Architect considers it necessary or advisable, the Architect shall have the authority to require inspection or testing of the Work in accordance with the provisions of the Contract Documents, whether or not the Work is fabricated, installed or completed. However, neither this authority of the Architect nor a decision made in good faith either to exercise or not to exercise such authority shall give rise to a duty or responsibility of the Architect to the Contractor, Subcontractors, suppliers, their agents or employees, or other persons or entities performing portions of the Work.

§ 3.6.2.3 The Architect shall interpret and decide matters concerning performance under, and requirements of, the Contract Documents on written request of either the Owner or Contractor. The Architect’s response to such requests shall be made in writing within any time limits agreed upon or otherwise with reasonable promptness.

§ 3.6.2.4 Interpretations and decisions of the Architect shall be consistent with the intent of, and reasonably inferable from, the Contract Documents and shall be in writing or in the form of drawings. When making such interpretations and decisions, the Architect shall endeavor to secure faithful performance by both Owner and Contractor, shall not show partiality to either, and shall not be liable for results of interpretations or decisions rendered in good faith. The Architect’s decisions on matters relating to aesthetic effect shall be final subject to the Owner’s written determination if consistent with the intent expressed in the Contract Documents.

§ 3.6.2.5 Unless the Owner and Contractor designate another person to serve as an Initial Decision Maker, as that term is defined in AIA Document A201–2017, the Architect shall render initial decisions on Claims between the Owner and Contractor as provided in the Contract Documents.

§ 3.6.3 Certificates for Payment to Contractor

§ 3.6.3.1 The Architect shall review and certify the amounts due the Contractor and shall issue certificates in such amounts.

The Architect's certification for payment shall constitute a representation to the Owner, based on the Architect's evaluation of the Work as provided in Section 3.6.2 and on the data comprising the Contractor's Application for Payment, that, to the best of the Architect's knowledge, information and belief, the Work has progressed to the point indicated, the quality of the Work is in accordance with the Contract Documents, and that the Contractor is entitled to payment in the amount certified. The foregoing representations are subject to (1) an evaluation of the Work for conformance with the Contract Documents upon Substantial Completion, (2) results of subsequent tests and inspections, (3) correction of minor deviations from the Contract Documents prior to completion, and (4) specific qualifications expressed by the Architect.

§ 3.6.3.2 The issuance of a Certificate for Payment shall not be a representation that the Architect has (1) made exhaustive or continuous on-site inspections to check the quality or quantity of the Work, (2) reviewed construction means, methods, techniques, sequences or procedures, (3) reviewed copies of requisitions received from Subcontractors and suppliers and other data requested by the Owner to substantiate the Contractor's right to payment, or (4) ascertained how or for what purpose the Contractor has used money previously paid on account of the Contract Sum.

§ 3.6.3.3 The Architect shall maintain a record of the Applications and Certificates for Payment.

§ 3.6.4 Submittals

§ 3.6.4.1 The Architect shall review the Contractor's submittal schedule and shall not unreasonably delay or withhold approval of the schedule. The Architect's action in reviewing submittals shall be taken in accordance with the approved submittal schedule or, in the absence of an approved submittal schedule, with reasonable promptness while allowing sufficient time, in the Architect's professional judgment, to permit adequate review.

§ 3.6.4.2 The Architect shall review and approve, or take other appropriate action upon, the Contractor's submittals such as Shop Drawings, Product Data and Samples, but only for the limited purpose of checking for conformance with information given and the design concept expressed in the Contract Documents. Review of such submittals is not for the purpose of determining the accuracy and completeness of other information such as dimensions, quantities, and installation or performance of equipment or systems, which are the Contractor's responsibility. The Architect's review shall not constitute approval of safety precautions or construction means, methods, techniques, sequences or procedures. The Architect's approval of a specific item shall not indicate approval of an assembly of which the item is a component.

§ 3.6.4.3 If the Contract Documents specifically require the Contractor to provide professional design services or certifications by a design professional related to systems, materials, or equipment, the Architect shall specify the appropriate performance and design criteria that such services must satisfy. The Architect shall review and take appropriate action on Shop Drawings and other submittals related to the Work designed or certified by the Contractor's design professional, provided the submittals bear such professional's seal and signature when submitted to the Architect. The Architect's review shall be for the limited purpose of checking for conformance with information given and the design concept expressed in the Contract Documents. The Architect shall be entitled to rely upon, and shall not be responsible for, the adequacy and accuracy of the services, certifications, and approvals performed or provided by such design professionals.

§ 3.6.4.4 Subject to Section 4.2, the Architect shall review and respond to requests for information about the Contract Documents. The Architect shall set forth, in the Contract Documents, the requirements for requests for information. Requests for information shall include, at a minimum, a detailed written statement that indicates the specific Drawings or Specifications in need of clarification and the nature of the clarification requested. The Architect's response to such requests shall be made in writing within any time limits agreed upon, or otherwise with reasonable promptness. If appropriate, the Architect shall prepare and issue supplemental Drawings and Specifications in response to the requests for information.

§ 3.6.4.5 The Architect shall maintain a record of submittals and copies of submittals supplied by the Contractor in accordance with the requirements of the Contract Documents.

§ 3.6.5 Changes in the Work

§ 3.6.5.1 The Architect may order minor changes in the Work that are consistent with the intent of the Contract Documents and do not involve an adjustment in the Contract Sum or an extension of the Contract Time. Subject to Section 4.2, the Architect shall prepare Change Orders and Construction Change Directives for the Owner's approval and execution in accordance with the Contract Documents.

§ 3.6.5.2 The Architect shall maintain records relative to changes in the Work.

§ 3.6.6 Project Completion

§ 3.6.6.1 The Architect shall:

- .1 conduct inspections to determine the date or dates of Substantial Completion and the date of final completion;
- .2 issue Certificates of Substantial Completion;
- .3 forward to the Owner, for the Owner’s review and records, written warranties and related documents required by the Contract Documents and received from the Contractor; and,
- .4 issue a final Certificate for Payment based upon a final inspection indicating that, to the best of the Architect’s knowledge, information, and belief, the Work complies with the requirements of the Contract Documents.

§ 3.6.6.2 The Architect’s inspections shall be conducted with the Owner to check conformance of the Work with the requirements of the Contract Documents and to verify the accuracy and completeness of the list submitted by the Contractor of Work to be completed or corrected.

§ 3.6.6.3 When Substantial Completion has been achieved, the Architect shall inform the Owner about the balance of the Contract Sum remaining to be paid the Contractor, including the amount to be retained from the Contract Sum, if any, for final completion or correction of the Work.

§ 3.6.6.4 The Architect shall forward to the Owner the following information received from the Contractor: (1) consent of surety or sureties, if any, to reduction in or partial release of retainage or the making of final payment; (2) affidavits, receipts, releases and waivers of liens, or bonds indemnifying the Owner against liens; and (3) any other documentation required of the Contractor under the Contract Documents.

§ 3.6.6.5 Upon request of the Owner, and prior to the expiration of one year from the date of Substantial Completion, the Architect shall, without additional compensation, conduct a meeting with the Owner to review the facility operations and performance.

ARTICLE 4 SUPPLEMENTAL AND ADDITIONAL SERVICES

§ 4.1 Supplemental Services

§ 4.1.1 The services listed below are not included in Basic Services but may be required for the Project. The Architect shall provide the listed Supplemental Services only if specifically designated in the table below as the Architect’s responsibility, and the Owner shall compensate the Architect as provided in Section 11.2. Unless otherwise specifically addressed in this Agreement, if neither the Owner nor the Architect is designated, the parties agree that the listed Supplemental Service is not being provided for the Project. For clarity, any item identified in the table as “Architect (included in Basic Services)” shall be deemed included in Basic Services and shall not be compensated as Supplemental Services.

(Designate the Architect’s Supplemental Services and the Owner’s Supplemental Services required for the Project by indicating whether the Architect or Owner shall be responsible for providing the identified Supplemental Service. Insert a description of the Supplemental Services in Section 4.1.2 below or attach the description of services as an exhibit to this Agreement.)

Supplemental Services	Responsibility <i>(Architect, Owner, or not provided)</i>
§ 4.1.1.1 Programming	Architect (included in Basic Services)
§ 4.1.1.2 Multiple preliminary designs	N/A
§ 4.1.1.3 Measured drawings	N/A
§ 4.1.1.4 Existing facilities surveys	N/A
§ 4.1.1.5 Site evaluation and planning	N/A
§ 4.1.1.6 Building Information Model management responsibilities	Architect
§ 4.1.1.7 Development of Building Information Models for post construction use	N/A
§ 4.1.1.8 Civil engineering	Architect (included in Basic Services)
§ 4.1.1.9 Landscape design	Architect (included in Basic Services)

§ 4.1.1.10	Architectural interior design	Architect (included in Basic Services)
§ 4.1.1.11	Value analysis	N/A
§ 4.1.1.12	Detailed cost estimating beyond that required in Section 6.3	N/A
§ 4.1.1.13	On-site project representation	N/A
§ 4.1.1.14	Conformed documents for construction	Architect (included in Basic Services)
§ 4.1.1.15	As-designed record drawings	N/A
§ 4.1.1.16	As-constructed record drawings	Architect (included in Basic Services)
§ 4.1.1.17	Post-occupancy evaluation	N/A
§ 4.1.1.18	Facility support services	N/A
§ 4.1.1.19	Tenant-related services	N/A
§ 4.1.1.20	Architect's coordination of the Owner's consultants	Architect (included in Basic Services)
§ 4.1.1.21	Telecommunications/data design	Low voltage pathways established by the electrical engineer. Final cable pulls and installation of IT system by owner's preferred vendor.
§ 4.1.1.22	Security evaluation and planning	N/A
§ 4.1.1.23	Commissioning	N/A
§ 4.1.1.24	Sustainable Project Services pursuant to Section 4.1.3	N/A
§ 4.1.1.25	Fast-track design services	N/A
§ 4.1.1.26	Multiple bid packages	N/A
§ 4.1.1.27	Historic preservation	N/A
§ 4.1.1.28	Furniture, furnishings, and equipment design	N/A
§ 4.1.1.29	Other services provided by specialty Consultants	N/A
§ 4.1.1.30	Other Supplemental Services	N/A

§ 4.1.2 Description of Supplemental Services

§ 4.1.2.1 A description of each Supplemental Service identified in Section 4.1.1 as the Architect's responsibility is provided below.

(Describe in detail the Architect's Supplemental Services identified in Section 4.1.1 or, if set forth in an exhibit, identify the exhibit. The AIA publishes a number of Standard Form of Architect's Services documents that can be included as an exhibit to describe the Architect's Supplemental Services.)

For the Supplemental Services table above, Supplemental Services (if any) shall be as described in Exhibit (Architect Proposal dated November 24, 2025), solely to the extent expressly incorporated and not inconsistent with this Agreement. In the event of a conflict, this Agreement controls.

§ 4.1.2.2 A description of each Supplemental Service identified in Section 4.1.1 as the Owner's responsibility is provided below.

(Describe in detail the Owner's Supplemental Services identified in Section 4.1.1 or, if set forth in an exhibit, identify the exhibit.)

N/A

§ 4.1.3 If the Owner identified a Sustainable Objective in Article 1, the Architect shall provide, as a Supplemental Service, the Sustainability Services required in AIA Document E204™-2017, Sustainable Projects Exhibit, attached to this Agreement. The Owner shall compensate the Architect as provided in Section 11.2.

§ 4.2 Architect's Additional Services

The Architect may provide Additional Services after execution of this Agreement without invalidating the Agreement. Except for services required due to the fault of the Architect, any Additional Services provided in accordance with this Section 4.2 shall entitle the Architect to compensation pursuant to Section 11.3 and an appropriate adjustment in the Architect's schedule. Any written authorization for Additional Services shall identify the scope, the fee (or a not-to-exceed amount), and any schedule adjustment. No Additional Services shall be deemed authorized by silence, course of dealing, partial performance or the Owner's failure to object, absent the express provisions of Section 4.2.2.

§ 4.2.1 Upon recognizing the need to perform the following Additional Services, the Architect shall notify the Owner with reasonable promptness and explain the facts and circumstances giving rise to the need. The Architect shall not proceed to provide the following Additional Services until the Architect receives the Owner's written authorization:

- .1 Services necessitated by a change in the Initial Information, previous instructions or approvals given by the Owner, or a material change in the Project including size, quality, complexity, the Owner's schedule or budget for Cost of the Work, or procurement or delivery method;
- .2 Services necessitated by the enactment or revision of codes, laws, or regulations, including changing or editing previously prepared Instruments of Service;
- .3 Changing or editing previously prepared Instruments of Service necessitated by official interpretations of applicable codes, laws or regulations that are either (a) contrary to specific interpretations by the applicable authorities having jurisdiction made prior to the issuance of the building permit, or (b) contrary to requirements of the Instruments of Service when those Instruments of Service were prepared in accordance with the applicable standard of care;
- .4 Services necessitated by decisions of the Owner not rendered in a timely manner or any other failure of performance on the part of the Owner or the Owner's consultants or contractors;
- .5 Preparing digital models or other design documentation for transmission to the Owner's consultants and contractors, or to other Owner-authorized recipients;
- .6 Preparation of design and documentation for alternate bid or proposal requests proposed by the Owner;
- .7 Preparation for, and attendance at, a public presentation, meeting or hearing, other than routine project meetings, Village Board/committee meetings reasonably anticipated for approvals, and agency meetings required in the normal course of permitting and review, all of which are included in Basic Services;
- .8 Preparation for, and attendance at, a dispute resolution proceeding or legal proceeding, except where the Architect is party thereto;
- .9 Evaluation of the qualifications of entities providing bids or proposals;
- .10 Consultation concerning replacement of Work resulting from fire or other cause during construction; or,
- .11 Assistance to the Initial Decision Maker, if other than the Architect.

§ 4.2.2 To avoid delay in the Construction Phase, the Architect may provide the following Additional Services only to the extent reasonably necessary to prevent material delay to the Project and where it is not practicable to obtain the Owner's prior written authorization. The Architect shall notify the Owner with reasonable promptness and explain the facts and circumstances giving rise to the need for such services, and shall use reasonable efforts to minimize the scope and cost of any such services. If, upon receipt of the Architect's notice, the Owner determines that all or part of the services are not required, the Owner shall give prompt written notice to the Architect of the Owner's determination. The Owner shall compensate the Architect only for those services that were reasonably performed prior to the Architect's receipt of the Owner's notice and that were necessary to avoid material delay.

- .1 Reviewing a Contractor's submittal out of sequence from the submittal schedule approved by the Architect;
- .2 Responding to the Contractor's requests for information that are not prepared in accordance with the Contract Documents or where such information is available to the Contractor from a careful study and comparison of the Contract Documents, field conditions, other Owner-provided information, Contractor-prepared coordination drawings, or prior Project correspondence or documentation;
- .3 Preparing Change Orders and Construction Change Directives that require evaluation of Contractor's proposals and supporting data, or the preparation or revision of Instruments of Service;
- .4 Evaluating an extensive number of Claims as the Initial Decision Maker; or,
- .5 Evaluating substitutions proposed by the Owner or Contractor and making subsequent revisions to Instruments of Service resulting therefrom.

§ 4.2.3 The Architect shall provide Construction Phase Services exceeding the limits set forth below as Additional Services.

AIA Document B101 – 2017. Copyright © 1974, 1978, 1987, 1997, 2007 and 2017. All rights reserved. "The American Institute of Architects," "American Institute of Architects," "AIA," the AIA Logo, and "AIA Contract Documents" are trademarks of The American Institute of Architects. This draft was produced at 11:10:00 CST on 11/18/2025 under Subscription No.20250137596 which expires on , is not for resale, is licensed for one-time use only, and may only be used in accordance with the AIA Contract Documents® Terms of Service. To report copyright violations, e-mail docinfo@aiaccontracts.com.

User Notes:

(640e2aedf442e4498d0967f7)

When the limits below are reached, the Architect shall notify the Owner:

- .1 Two (2) reviews of each Shop Drawing, Product Data item, sample and similar submittals of the Contractor.
- .2 Twenty-Four (24) visits to the site by the Architect during construction. Site visits by the Construction Manager or other Owner representatives shall not be counted toward this limit unless the Architect is present.
- .3 Eighteen (18) inspections for designated portions of the Work as identified in the Owner-Contractor schedule or Certificate(s) of Substantial Completion in accordance with the requirements of the Contract Documents.
- .4 One (1) inspections for any portion of the Work to determine final completion.

§ 4.2.4 Except for services required under Section 3.6.6.5 and those services that do not exceed the limits set forth in Section 4.2.3, Construction Phase Services provided more than one hundred twenty (120) days after (1) the date of Substantial Completion of the Work or (2) the initial date of Substantial Completion identified in the agreement between the Owner and Contractor, whichever is earlier, shall be compensated as Additional Services only to the extent that such services are beyond the Architect's ordinary close-out obligations, are not caused by the Architect or its consultants, and result in demonstrable additional cost to the Architect.

§ 4.2.5 If the services covered by this Agreement have not been completed within Twenty-Four (24) months of the date of this Agreement, through no fault of the Architect, extension of the Architect's services beyond that time shall be compensated as Additional Services only after the Architect provides written notice and a proposed fee basis (including rates) and receives the Owner's written authorization.

ARTICLE 5 OWNER'S RESPONSIBILITIES

§ 5.1 Unless otherwise provided for under this Agreement, the Owner shall provide information in a timely manner regarding requirements for and limitations on the Project, including a written program, which shall set forth the Owner's objectives; schedule; constraints and criteria, including space requirements and relationships; flexibility; expandability; special equipment; systems; and site requirements. The Owner's program and information are furnished without warranty as to completeness or accuracy and shall be subject to the Architect's professional review consistent with the applicable standard of care.

§ 5.2 The Owner shall establish the Owner's budget for the Project, including (1) the budget for the Cost of the Work as defined in Section 6.1; (2) the Owner's other costs; and, (3) reasonable contingencies related to all of these costs. The Owner shall update the Owner's budget for the Project as necessary throughout the duration of the Project until final completion. If the Owner significantly increases or decreases the Owner's budget for the Cost of the Work, the Owner shall notify the Architect. The Owner and the Architect shall thereafter consider and, if mutually agreed in writing, implement a corresponding change in the Project's scope and quality.

§ 5.3 The Owner shall identify a representative authorized to act on the Owner's behalf with respect to the Project. The Owner shall render decisions and approve the Architect's submittals in a timely manner in order to avoid unreasonable delay in the orderly and sequential progress of the Architect's services. Owner decisions and approvals shall be subject to applicable public-body meeting schedules, statutory requirements, and governance procedures, and shall not constitute unreasonable delay absent circumstances beyond those constraints.

§ 5.4 The Owner shall furnish surveys to describe physical characteristics, legal limitations and utility locations for the site of the Project, and a written legal description of the site. The surveys and legal information shall include, as applicable, grades and lines of streets, alleys, pavements and adjoining property and structures; designated wetlands; adjacent drainage; rights-of-way, restrictions, easements, encroachments, zoning, deed restrictions, boundaries and contours of the site; locations, dimensions, and other necessary data with respect to existing buildings, other improvements and trees; and information concerning available utility services and lines, both public and private, above and below grade, including inverts and depths. All the information on the survey shall be referenced to a Project benchmark.

§ 5.5 The Owner shall furnish services of geotechnical engineers, which may include test borings, test pits, determinations of soil bearing values, percolation tests, evaluations of hazardous materials, seismic evaluation, ground corrosion tests and resistivity tests, including necessary operations for anticipating subsoil conditions, with written reports and appropriate recommendations.

§ 5.6 The Owner shall provide the Supplemental Services designated as the Owner's responsibility in Section 4.1.1.

§ 5.7 If the Owner identified a Sustainable Objective in Article 1, the Owner shall fulfill its responsibilities as required in AIA Document E204™–2017, Sustainable Projects Exhibit, attached to this Agreement.

§ 5.8 The Owner shall coordinate the services of its own consultants with those services provided by the Architect. Upon the Architect's request, the Owner shall furnish copies of the scope of services in the contracts between the Owner and the Owner's consultants. The Owner shall furnish the services of consultants other than those designated as the responsibility of the Architect in this Agreement, or authorize the Architect to furnish them as an Additional Service, subject to the Owner's prior written approval, when the Architect requests such services and demonstrates that they are reasonably required by the scope of the Project. The Owner shall require that its consultants and contractors maintain insurance, including professional liability insurance, as appropriate to the services or work provided.

§ 5.9 The Owner shall furnish tests, inspections and reports required by law or the Contract Documents, such as structural, mechanical, and chemical tests, tests for air and water pollution, and tests for hazardous materials.

§ 5.10 The Owner shall furnish all legal, insurance and accounting services, including auditing services, that may be reasonably necessary at any time for the Project to meet the Owner's needs and interests.

§ 5.11 The Owner shall provide prompt written notice to the Architect if the Owner becomes aware of any fault or defect in the Project, including errors, omissions or inconsistencies in the Architect's Instruments of Service provided that failure to provide such notice shall not waive the Owner's rights or remedies except to the extent the Architect is materially prejudiced thereby.

§ 5.12 The Owner shall include the Architect in all communications with the Contractor that relate to or affect the Architect's services or professional responsibilities to the extent reasonably practicable. The Owner shall promptly notify the Architect of the substance of any direct communications between the Owner and the Contractor otherwise relating to the Project. Communications by and with the Architect's consultants shall be through the Architect. Nothing in this Section shall prohibit the Owner from communicating directly with the Contractor regarding safety, emergencies, or administrative matters, provided the Architect is promptly informed.

§ 5.13 Before executing the Contract for Construction, the Owner shall coordinate the Architect's duties and responsibilities set forth in the Contract for Construction with the Architect's services set forth in this Agreement. The Owner shall provide the Architect a copy of the executed agreement between the Owner and Contractor, including the General Conditions of the Contract for Construction.

§ 5.14 The Owner shall provide the Architect access to the Project site prior to commencement of the Work and shall obligate the Contractor to provide the Architect access to the Work wherever it is in preparation or progress.

§ 5.15 Within 15 days after receipt of a written request from the Architect, the Owner shall furnish the requested information as necessary and relevant for the Architect to evaluate, give notice of, or enforce lien rights, to the extent such lien rights are applicable to the Project under Wisconsin law.

ARTICLE 6 COST OF THE WORK

§ 6.1 For purposes of this Agreement, the Cost of the Work shall be the total cost to the Owner to construct all elements of the Project designed or specified by the Architect and shall include contractors' general conditions costs, overhead and profit. The Cost of the Work also includes the reasonable value of labor, materials, and equipment, donated to, or otherwise furnished by, the Owner. The Cost of the Work does not include the compensation of the Architect; the costs of the land, rights-of-way, financing, or contingencies for changes in the Work; or other costs that are the responsibility of the Owner. The Cost of the Work shall be based on the Project as designed in accordance with the Owner's approved program, scope, and budget assumptions.

§ 6.2 The Owner's budget for the Cost of the Work is provided in Initial Information, and shall be adjusted throughout the Project as required under Sections 5.2, 6.4 and 6.5. Evaluations of the Owner's budget for the Cost of the Work, and the preliminary estimate of the Cost of the Work and updated estimates of the Cost of the Work, prepared by the Architect, represent the Architect's judgment as a design professional exercised consistent with the applicable standard of care. It is recognized, however, that neither the Architect nor the Owner has control over the cost of labor, materials, or equipment; the Contractor's methods of determining bid prices; or competitive bidding, market, or negotiating conditions. Accordingly, the

Architect cannot and does not warrant or represent that bids or negotiated prices will not vary from the Owner's budget for the Cost of the Work, or from any estimate of the Cost of the Work, or evaluation, prepared or agreed to by the Architect.

§ 6.3 In preparing estimates of the Cost of Work, the Architect shall be permitted to include contingencies for design, bidding, and price escalation; to determine what materials, equipment, component systems, and types of construction are to be included in the Contract Documents; to recommend reasonable adjustments in the program and scope of the Project; and to include design alternates as may be necessary to adjust the estimated Cost of the Work to meet the Owner's budget. The Architect's estimate of the Cost of the Work shall be based on current area, volume or similar conceptual estimating techniques. If the Owner requires a detailed estimate of the Cost of the Work, the Architect shall provide such an estimate, if identified as the Architect's responsibility in Section 4.1.1, as a Supplemental Service. Any recommended adjustments to the program, scope, or quality of the Project shall be subject to the Owner's prior written approval.

§ 6.4 If, through no fault of the Architect, the Procurement Phase has not commenced within ninety (90) days after the Architect submits the Construction Documents to the Owner, the Owner's budget for the Cost of the Work may be adjusted, upon mutual agreement of the Owner and Architect, to reflect changes in the general level of prices in the applicable construction market, taking into account public-body approval processes and funding constraints.

§ 6.5 If at any time the Architect's estimate of the Cost of the Work exceeds the Owner's budget for the Cost of the Work, the Architect shall make appropriate recommendations to the Owner to adjust the Project's size, quality, or budget for the Cost of the Work, and the Owner shall consider, in good faith, whether to cooperate with the Architect in making such adjustments.

§ 6.6 If the Owner's budget for the Cost of the Work at the conclusion of the Construction Documents Phase Services is exceeded by the lowest bona fide bid or negotiated proposal, the Owner shall

- .1 give written approval of an increase in the budget for the Cost of the Work;
- .2 authorize rebidding or renegotiating of the Project within a reasonable time;
- .3 terminate in accordance with Section 9.5;
- .4 in consultation with the Architect, revise the Project program, scope, or quality as required to reduce the Cost of the Work; or,
- .5 implement any other mutually acceptable alternative.

§ 6.7 If the Owner chooses to proceed under Section 6.6.4, the Architect shall modify the Construction Documents as necessary to comply with the Owner's budget for the Cost of the Work at the conclusion of the Construction Documents Phase Services, or the budget as adjusted under Section 6.6.1. If the Owner requires the Architect to modify the Construction Documents because the lowest bona fide bid or negotiated proposal exceeds the Owner's budget for the Cost of the Work due to market conditions that were not reasonably foreseeable and were not reflected in the Architect's prior estimates, the Owner shall compensate the Architect for the modifications as an Additional Service pursuant to Section 11.3; otherwise the Architect's services for modifying the Construction Documents shall be without additional compensation. In any event, the Architect's modification of the Construction Documents shall be the limit of the Architect's responsibility under this Article 6, provided that this limitation shall not apply to errors, omissions, or failures to meet the applicable standard of care.

ARTICLE 7 COPYRIGHTS AND LICENSES

§ 7.1 The Architect and the Owner warrant that in transmitting Instruments of Service, or any other information, the transmitting party is the copyright owner of such information or has permission from the copyright owner to transmit such information for its use on the Project.

§ 7.2 The Architect and the Architect's consultants shall be deemed the authors and owners of their respective Instruments of Service, including the Drawings and Specifications, and shall retain all common law, statutory and other reserved rights, including copyrights. Submission or distribution of Instruments of Service to meet official regulatory requirements or for similar purposes in connection with the Project is not to be construed as publication in derogation of the reserved rights of the Architect and the Architect's consultants.

§ 7.3 The Architect grants to the Owner a nonexclusive license to use the Architect's Instruments of Service solely and exclusively for purposes of constructing, using, maintaining, altering and adding to the Project, provided that the Owner substantially performs its obligations under this Agreement, including prompt payment of all sums due pursuant to Article 9 and Article 11.. The Architect shall obtain similar nonexclusive licenses from the Architect's consultants consistent with this Agreement. The license granted under this section permits the Owner to authorize the Contractor, Subcontractors, Sub-

subcontractors, and suppliers, as well as the Owner's consultants and separate contractors, to reproduce applicable portions of the Instruments of Service, subject to any protocols established pursuant to Section 1.3, solely and exclusively for use in performing services or construction for the Project. If this Agreement is terminated for any reason, including termination for cause, the Owner shall retain a nonexclusive license to use the Instruments of Service solely for purposes of completing, operating, maintaining, and modifying the Project, provided that the Owner has paid all undisputed amounts due to the Architect.

§ 7.3.1 In the event the Owner uses the Instruments of Service without retaining the authors of the Instruments of Service, the Owner releases the Architect and Architect's consultant(s) from all claims and causes of action to the extent arising from the Owner's modification of, or reliance upon, the Instruments of Service without the Architect's involvement. The Owner, to the extent permitted by law, further agrees to indemnify and hold harmless the Architect and its consultants from all costs and expenses, including the cost of defense, related to claims and causes of action asserted by any third person or entity to the extent such costs and expenses arise from the Owner's modification of, or reliance upon, the Instruments of Service without the Architect's involvement, but excluding claims arising from the Architect's or its consultants' negligence, errors, or omissions. The terms of this Section 7.3.1 shall not apply if the Owner rightfully terminates this Agreement for cause under Section 9.4.

§ 7.4 Except for the licenses granted in this Article 7, no other license or right shall be deemed granted or implied under this Agreement. The Owner shall not assign, delegate, sublicense, pledge or otherwise transfer any license granted herein to another party while the Architect is not being paid amounts undisputedly due under this Agreement, without the prior written agreement of the Architect. Any unauthorized use of the Instruments of Service outside the scope of the licenses granted in this Article 7 shall be at the Owner's sole risk and without liability to the Architect and the Architect's consultants.

§ 7.5 Except as otherwise stated in Section 7.3, the provisions of this Article 7 shall survive the termination of this Agreement.

ARTICLE 8 CLAIMS AND DISPUTES

§ 8.1 General

§ 8.1.1 The Owner and Architect shall commence all claims and causes of action against the other and arising out of or related to this Agreement, whether in contract, tort, or otherwise, in accordance with the requirements of the binding dispute resolution method selected in this Agreement and within the period specified by applicable law, but in any case not more than 10 years after the date of Substantial Completion of the Work, to the extent permitted by applicable law. The Owner and Architect waive all claims and causes of action not commenced in accordance with this Section 8.1.1, to the extent permitted by applicable law.

§ 8.1.2 To the extent damages are covered by property insurance, the Owner and Architect waive all rights against each other and against the contractors, consultants, agents, and employees of the other for damages, except such rights as they may have to the proceeds of such insurance as set forth in AIA Document A201-2017, General Conditions of the Contract for Construction. The Owner or the Architect, as appropriate, shall require of the contractors, consultants, agents, and employees of any of them, similar waivers in favor of the other parties enumerated herein.

§ 8.1.3 The Architect and Owner waive consequential damages for claims, disputes, or other matters in question, arising out of or relating to this Agreement. This mutual waiver is applicable, without limitation, to all consequential damages due to either party's termination of this Agreement, except as specifically provided in Section 9.7, and except to the extent such damages arise from willful misconduct or violations of applicable law.

§ 8.2 Mediation

§ 8.2.1 Any claim, dispute or other matter in question arising out of or related to this Agreement may be submitted to mediation by mutual agreement of the Owner and Architect, but mediation shall not be a condition precedent to the commencement of litigation or other dispute resolution proceedings. If such matter relates to or is the subject of a lien arising out of the Architect's services, the Architect may proceed in accordance with applicable law to comply with the lien notice or filing deadlines prior to resolution of the matter by mediation or by binding dispute resolution.

§ 8.2.2 The Owner and Architect shall endeavor to resolve claims, disputes and other matters in question between them by mediation, if mutually agreed, which, unless the parties mutually agree otherwise, shall be administered by the American Arbitration Association in accordance with its Construction Industry Mediation Procedures in effect on the date of this Agreement. A request for mediation shall be made in writing, delivered to the other party to this Agreement, and filed with the

person or entity administering the mediation. The request may be made concurrently with the filing of a complaint or other appropriate demand for binding dispute resolution but, in such event, mediation shall proceed in advance of binding dispute resolution proceedings, which shall be stayed pending mediation for a period of 60 days from the date of filing, unless stayed for a longer period by agreement of the parties or court order. If an arbitration proceeding is stayed pursuant to this section, the parties may nonetheless proceed to the selection of the arbitrator(s) and agree upon a schedule for later proceedings. Any participation by the Owner in mediation shall be subject to applicable public-body approval requirements and shall not obligate the Owner to settle any claim absent such approvals.

§ 8.2.3 The parties shall share the mediator’s fee and any filing fees equally. The mediation shall be held in the place where the Project is located, unless another location is mutually agreed upon. Agreements reached in mediation shall be enforceable as settlement agreements in any court having jurisdiction thereof.

§ 8.2.4 If the parties do not resolve a dispute through mediation pursuant to this Section 8.2, the method of binding dispute resolution shall be the following:

(Check the appropriate box.)

- Arbitration pursuant to Section 8.3 of this Agreement
- Litigation in a court of competent jurisdiction
- Other: *(Specify)*

If the Owner and Architect do not select a method of binding dispute resolution, or do not subsequently agree in writing to a binding dispute resolution method other than litigation, the dispute will be resolved in a court of competent jurisdiction. Any litigation shall be brought in a state court located in the county in which the Project is located, unless otherwise required by law.

§ 8.4 The provisions of this Article 8 shall survive the termination of this Agreement.

ARTICLE 9 TERMINATION OR SUSPENSION

§ 9.1 If the Owner fails to make payments to the Architect of undisputed amounts in accordance with this Agreement, and such failure continues for fourteen (14) days after written notice, such failure shall be considered substantial nonperformance and cause for termination or, at the Architect’s option, cause for suspension of performance of services under this Agreement. If the Architect elects to suspend services, the Architect shall give seven days’ written notice to the Owner before suspending services. In the event of a suspension of services, the Architect shall have no liability to the Owner for delay or damage caused the Owner because of such suspension of services provided that such suspension is exercised in good faith and in compliance with this Section 9.1. Before resuming services, the Owner shall pay the Architect all sums due prior to suspension and any expenses incurred in the interruption and resumption of the Architect’s services. The Architect’s fees for the remaining services and the time schedules shall be equitably adjusted.

§ 9.2 If the Owner suspends the Project, the Architect shall be compensated for services performed prior to notice of such suspension. When the Project is resumed, the Architect shall be compensated for reasonable, documented expenses incurred in the interruption and resumption of the Architect’s services. The Architect’s fees for the remaining services and the time schedules shall be equitably adjusted.

§ 9.3 If the Owner suspends the Project for more than 90 cumulative days for reasons other than the fault of the Architect, the Architect may terminate this Agreement by giving not less than seven days’ written notice.

§ 9.4 Either party may terminate this Agreement upon not less than seven days’ written notice after providing written notice of the failure and a reasonable opportunity to cure, should the other party fail substantially to perform in accordance with the terms of this Agreement through no fault of the party initiating the termination.

§ 9.5 The Owner may terminate this Agreement upon not less than seven days’ written notice to the Architect for the Owner’s convenience and without cause.

§ 9.6 If the Owner terminates this Agreement for its convenience pursuant to Section 9.5, or the Architect terminates this

Agreement pursuant to Section 9.3, the Owner shall compensate the Architect for services performed prior to termination, Reimbursable Expenses incurred, and reasonable, documented, non-cancellable costs attributable to termination, including the costs attributable to the Architect's termination of consultant agreements.

§ 9.7 In addition to any amounts paid under Section 9.6, if the Owner terminates this Agreement for its convenience pursuant to Section 9.5, or the Architect terminates this Agreement pursuant to Section 9.3, the Owner shall pay to the Architect the following fees:

(Set forth below the amount of any termination or licensing fee, or the method for determining any termination or licensing fee.)

.1 Termination Fee:

N/A

.2 Licensing Fee if the Owner intends to continue using the Architect's Instruments of Service:

\$0.00. The Owner's rights to use the Architect's Instruments of Service following termination are governed exclusively by Article 7, and no additional licensing fee or waiver of professional liability shall be required.

§ 9.8 Except as otherwise expressly provided herein, this Agreement shall terminate one year from the date of Substantial Completion. Termination of this Agreement shall not affect the Owner's rights under Article 7.

§ 9.9 The Owner's rights to use the Architect's Instruments of Service in the event of a termination of this Agreement are set forth in Article 7 and Section 9.7.

ARTICLE 10 MISCELLANEOUS PROVISIONS

§ 10.1 This Agreement shall be governed by the law of the place where the Project is located, excluding that jurisdiction's choice of law rules. If the parties have selected arbitration as the method of binding dispute resolution, the Federal Arbitration Act shall govern Section 8.3.

§ 10.2 Terms in this Agreement shall have the same meaning as those in AIA Document A201-2017, General Conditions of the Contract for Construction, unless otherwise defined or modified in this Agreement.

§ 10.3 The Owner and Architect, respectively, bind themselves, their agents, successors, assigns, and legal representatives to this Agreement. Neither the Owner nor the Architect shall assign this Agreement without the written consent of the other, except that the Owner may assign this Agreement to a lender providing financing for the Project if the lender agrees to assume the Owner's rights and obligations under this Agreement, including any payments due to the Architect by the Owner prior to the assignment. Notwithstanding the foregoing, the Owner may assign this Agreement, without the Architect's consent, to a successor public entity, governmental authority, or entity assuming ownership or operational responsibility for the Project.

§ 10.4 If the Owner requests the Architect to execute certificates, the proposed language of such certificates shall be submitted to the Architect for review at least 14 days prior to the requested dates of execution, or such shorter period as may be reasonably requested under the circumstances. If the Owner requests the Architect to execute consents reasonably required to facilitate assignment to a lender, the Architect shall execute all such consents that are consistent with this Agreement, provided the proposed consent is submitted to the Architect for review at least 14 days prior to execution, or such shorter period as may be reasonably requested under the circumstances. The Architect shall not be required to execute certificates or consents that would require knowledge, services, or responsibilities beyond the scope of this Agreement.

§ 10.5 Nothing contained in this Agreement shall create a contractual relationship with, or a cause of action in favor of, a third party against either the Owner or Architect.

§ 10.6 Unless otherwise required in this Agreement, the Architect shall have no responsibility for the discovery, presence, handling, removal or disposal of, or exposure of persons to, hazardous materials or toxic substances in any form at the Project site.

§ 10.7 The Architect shall have the right to include photographic or artistic representations of the design of the Project among the Architect's promotional and professional materials. The Architect shall be given reasonable access to the completed Project subject to the Owner's security requirements and operational needs to make such representations. However, the Architect's materials shall not include the Owner's confidential or proprietary information if the Owner has previously advised the Architect in writing of the specific information considered by the Owner to be confidential or proprietary. The Owner shall provide professional credit for the Architect in the Owner's promotional materials for the Project. This Section 10.7 shall survive the termination of this Agreement unless the Owner terminates this Agreement for cause pursuant to Section 9.4. Nothing in this Section shall limit the Owner's obligations under applicable public records or open records laws.

§ 10.8 If the Architect or Owner receives information specifically designated as "confidential" or "business proprietary," the receiving party shall keep such information strictly confidential and shall not disclose it to any other person except as set forth in Section 10.8.1. This Section 10.8 shall survive the termination of this Agreement. Confidentiality obligations under this Section are subject to the Owner's obligations under applicable public records and open records laws.

§ 10.8.1 The receiving party may disclose "confidential" or "business proprietary" information after 7 days' notice to the other party, when required by law, arbitrator's order, or court order, including a subpoena or other form of compulsory legal process issued by a court or governmental entity, or to the extent such information is reasonably necessary for the receiving party to defend itself in any dispute. The receiving party may also disclose such information to its employees, consultants, or contractors in order to perform services or work solely and exclusively for the Project, provided those employees, consultants and contractors are subject to the restrictions on the disclosure and use of such information as set forth in this Section 10.8.

§ 10.9 The invalidity of any provision of the Agreement shall not invalidate the Agreement or its remaining provisions. If it is determined that any provision of the Agreement violates any law, or is otherwise invalid or unenforceable, then that provision shall be revised to the extent necessary to make that provision legal and enforceable. In such case the Agreement shall be construed, to the fullest extent permitted by law, to give effect to the parties' intentions and purposes in executing the Agreement.

ARTICLE 11 COMPENSATION

§ 11.1 For the Architect's Basic Services described under Article 3, the Owner shall compensate the Architect as follows:

- .1 Stipulated Sum
(Insert amount)

The amounts listed in the "Negotiated" column shown on Exhibit C.

The total compensation payable to the Architect under this Agreement, including Basic, Supplemental, and Additional Services, shall not exceed the amount authorized by the Owner in writing.

§ 11.2 For the Architect's Supplemental Services designated in Section 4.1.1 and for any Sustainability Services required pursuant to Section 4.1.3, the Owner shall compensate the Architect as follows:
(Insert amount of, or basis for, compensation. If necessary, list specific services to which particular methods of compensation apply.)

Based on the hourly rates set forth in Exhibit B, as in effect on the date of this Agreement, unless otherwise approved in advance in writing by the Owner.

§ 11.3 For Additional Services that may arise during the course of the Project, including those under Section 4.2, the Owner shall compensate the Architect as follows:
(Insert amount of, or basis for, compensation.)

Based on the hourly rates set forth in Exhibit B, as in effect on the date of this Agreement, unless otherwise approved in advance in writing by the Owner.

§ 11.4 Compensation for Supplemental and Additional Services of the Architect's consultants when not included in Section 11.2 or 11.3, shall be the reasonable, documented amount invoiced to the Architect plus ten percent (10%), or as follows:

(Insert amount of, or basis for computing, Architect's consultants' compensation for Supplemental or Additional Services.)

Based on the hourly rates set forth in Exhibit B, as in effect on the date of this Agreement, unless otherwise approved in advance in writing by the Owner.

Consultant services shall be subject to the same rate, documentation, and approval requirements applicable to the Architect under this Article 11.

§ 11.6 When compensation identified in Section 11.1 is on a percentage basis, progress payments for each phase of Basic Services shall be calculated by multiplying the percentages identified in this Article by the Owner's most recent budget for the Cost of the Work. Compensation paid in previous progress payments shall not be adjusted based on subsequent updates to the Owner's budget for the Cost of the Work.

§ 11.6.1 When compensation is on a percentage basis and any portions of the Project are deleted or otherwise not constructed, compensation for those portions of the Project shall be payable to the extent services are performed on those portions. The Architect shall be entitled to compensation in accordance with this Agreement for all services performed whether or not the Construction Phase is commenced.

§ 11.7 The hourly billing rates for services of the Architect and the Architect's consultants are set forth below. Hourly rates shall remain fixed for the duration of the Project unless otherwise approved in advance in writing by the Owner.
(If applicable, attach an exhibit of hourly billing rates or insert them below.)

§ 11.8 Compensation for Reimbursable Expenses

§ 11.8.1 Reimbursable Expenses are in addition to compensation for Basic, Supplemental, and Additional Services and include expenses incurred by the Architect and the Architect's consultants directly related to the Project, as follows:

- .1 Transportation and authorized out-of-town travel and subsistence;
- .2 Long distance services, dedicated data and communication services, teleconferences, Project web sites, and extranets;
- .3 Permitting and other fees required by authorities having jurisdiction over the Project;
- .4 Printing, reproductions, plots, and standard form documents;
- .5 Postage, handling, and delivery;
- .6 Expense of overtime work requiring higher than regular rates, if authorized in advance by the Owner;
- .7 Renderings, physical models, mock-ups, professional photography, and presentation materials requested by the Owner or required for the Project;
- .8 If required by the Owner, and with the Owner's prior written approval, the Architect's consultants' expenses of professional liability insurance dedicated exclusively to this Project, or the expense of additional insurance coverage or limits in excess of that normally maintained by the Architect's consultants;
- .9 All taxes levied on professional services and on reimbursable expenses;
- .10 Site office expenses only if expressly authorized in advance in writing by the Owner;
- .11 Registration fees and any other fees charged by the Certifying Authority or by other entities as necessary to achieve the Sustainable Objective; and,
- .12 Other similar Project-related expenditures.

Reimbursable Expenses shall be limited to actual, reasonable, and documented out-of-pocket costs and shall not include normal overhead expenses.

§ 11.8.2 For Reimbursable Expenses the compensation shall be the expenses incurred by the Architect and the Architect's consultants plus zero percent (0 %) of the expenses incurred.

§ 11.9 Architect's Insurance. If the types and limits of coverage required in Section 2.5 are in addition to the types and limits the Architect normally maintains, the Owner shall pay the Architect for the additional costs incurred by the Architect for the additional coverages as set forth below:

(Insert the additional coverages the Architect is required to obtain in order to satisfy the requirements set forth in Section 2.5, and for which the Owner shall reimburse the Architect.)

No additional coverages have been requested by the Owner as of the date of this Contract.

§ 11.10 Payments to the Architect

§ 11.10.1 Initial Payments

§ 11.10.1.1 An initial payment of zero (\$0.00) shall be made upon execution of this Agreement and is the minimum payment under this Agreement. It shall be credited to the Owner's account in the final invoice.

§ 11.10.1.2 If a Sustainability Certification is part of the Sustainable Objective, an initial payment to the Architect of N/A (\$ 0.00) shall be made upon execution of this Agreement for registration fees and other fees payable to the Certifying Authority and necessary to achieve the Sustainability Certification. The Architect's payments to the Certifying Authority shall be credited to the Owner's account at the time the expense is incurred.

§ 11.10.2 Progress Payments

§ 11.10.2.1 Unless otherwise agreed, payments for services shall be made monthly in proportion to services performed. Payments are due and payable upon presentation of the Architect's invoice. Amounts unpaid sixty (60) days after the invoice date shall bear interest at the rate entered below, or in the absence thereof at the legal rate prevailing from time to time at the principal place of business of the Architect.

(Insert rate of monthly or annual interest agreed upon.)

Interest, if any, shall accrue at the rate permitted under Wisconsin law.

§ 11.10.2.2 The Owner shall not withhold amounts from the Architect's compensation to impose a penalty or liquidated damages on the Architect, or to offset sums requested by or paid to contractors for the cost of changes in the Work, unless the Architect agrees or has been found liable for the amounts in a binding dispute resolution proceeding. Nothing in this Section shall limit the Owner's right to withhold payment as permitted by law or for disputed amounts.

§ 11.10.2.3 Records of Reimbursable Expenses, expenses pertaining to Supplemental and Additional Services, and services performed on the basis of hourly rates shall be available to the Owner at mutually convenient times and for a period of not less than three (3) years following final payment.

ARTICLE 12 SPECIAL TERMS AND CONDITIONS

Special terms and conditions that modify this Agreement are as follows:

(Include other terms and conditions applicable to this Agreement.)

N/A

ARTICLE 13 SCOPE OF THE AGREEMENT

§ 13.1 This Agreement represents the entire and integrated agreement between the Owner and the Architect and supersedes all prior negotiations, representations or agreements, either written or oral. This Agreement may be amended only by written instrument signed by both the Owner and Architect. In the event of any inconsistency between this Agreement and any exhibit or attachment, the terms of this Agreement shall govern.

§ 13.2 This Agreement is comprised of the following documents identified below:

- .1 AIA Document B101™–2017, Standard Form Agreement Between Owner and Architect
- .2 Building Information Modeling Exhibit, if completed:

- .3 Exhibits:
(Check the appropriate box for any exhibits incorporated into this Agreement.)

[] Other Exhibits incorporated into this Agreement:

(Clearly identify any other exhibits incorporated into this Agreement, including any exhibits and scopes of services identified as exhibits in Section 4.1.2.)

Exhibit A – The original proposal for professional services dated November 24, 2025, solely for purposes of identifying the scope of services, and expressly excluding any terms related to compensation, schedule, standard of care, limitation of liability, indemnification, termination, or dispute resolution.

Exhibit B – Professional rate table as in effect on the date of this Agreement.

Exhibit C – SEH Negotiated Fee Breakdown.

.4 Other documents:

(List other documents, if any, forming part of the Agreement.)

N/A

This Agreement entered into as of the day and year first written above.

OWNER *(Signature)*

John Delain, Fire Chief

(Printed name and title)

ARCHITECT *(Signature)*

Trevor M. Frank, AIA | Principal | Sr. Architect

(Printed name, title, and license number, if required)